

272086

DELUXE NON-SPARKING DRUM PLUG WRENCH

FEATURES:

- HANDLES BUNG PATTERNS 1,2,3, & 5.
- BRONZE ALLOY.
- STRONGFR THAN ALUMINUM.
- OFFSET HANDLE DESIGN REDUCES USER STRESS AND MINIMIZES KNUCKLE INJURY.
- BUILT-IN 1.25" WRENCH FOR TIGHTENING FAUCETS INTO DRUMS.
- MINIMUM ORDER QTY. 3

WARNING: Bronze or Brass components of this product contain lead or arsenic. The state of California under Proposition 65 has determined that exposure to these chemicals is known to cause cancer or birth defects or other reprodu

WEIGHT: 3 LBS.
 BOXED: YES
 BOXED SIZE: 12-1/2" x 3" x 2-1/4" PER PIECE.

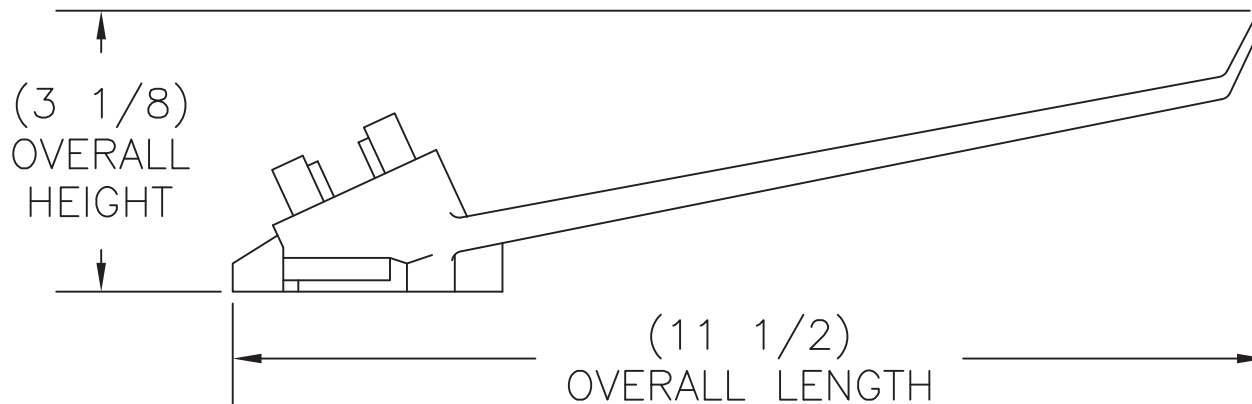

NOTE:
 OVERALL WIDTH
 (3 5/8)

THIS DRAWING IN ALL PARTICULARS IS WESCO INDUSTRIAL PRODUCTS INC. PROPERTY. ALL RIGHTS OF DESIGN, INVENTION OR USE OF ARE RESERVED.

		APP	WESCO INDUSTRIAL PRODUCTS INC. NORTH WALES PENNA. 19454		DRAWN: RWS 06-18-13	
		ECN & DATE			PART NAME DELUXE NON-SPARKING DRUM PLUG WRENCH	
		REVISIONS	TOLERANCE UNLESS OTHERWISE SPECIFIED		APP. ENGR.	
			FRACTION 3 PLACE DECIMAL 2 PLACE DECIMAL		SCALE: 1" = 1"	
			± 1/64 ± .005 ± .01		A-272086	
		REV.	ANGULAR ± 1-1/2' SHEET 1 OF 1		REV	A
		BREAK ALL SHARP EDGES AND REMOVE ALL BURRS				

Looking for dependable wrenches and sets? Rely on Wesco Industrial for quality and long-lasting products.