

Viking V100 Timing Procedure

STEP 1

Disassemble tool, remove twelve screws from the side straps, remove side straps, remove carrier, then inspect all gears to make sure that they are not chipped, worn, etc.

STEP 2

Lay the tool on its side with the knob to the left and the handle to the right. Install the actuator gear into the center hole of the body; make sure that the actuator gear is properly engaged by being flush with the body. Turn the actuator gear so that both timing marks line up (12 o'clock position).

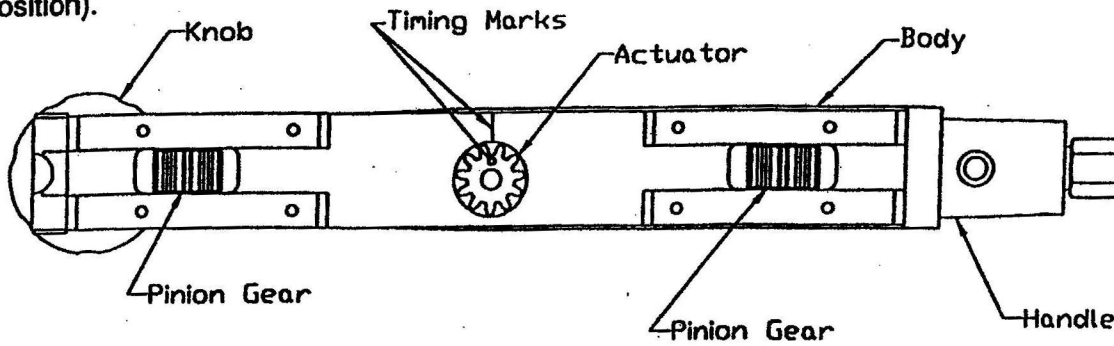

STEP 3

Make sure that the pinion gears turn freely in each direction. Then rotate each of the pinion gears toward the center of the tool until they stop. Then rotate the gears in the opposite direction until the next tooth is centered. Rotate the pinion gears in the same direction, four more teeth. The pinion gears are now centered.

STEP 4

Locate the center valleys of the rack gears, located on the carrier. While aligning these valleys with the center tooth of the pinion gears, also align the center of the actuator rack gear with the center tooth of the actuator gear. Use extreme care not to move any of the previously timed gears on the body of the tool.

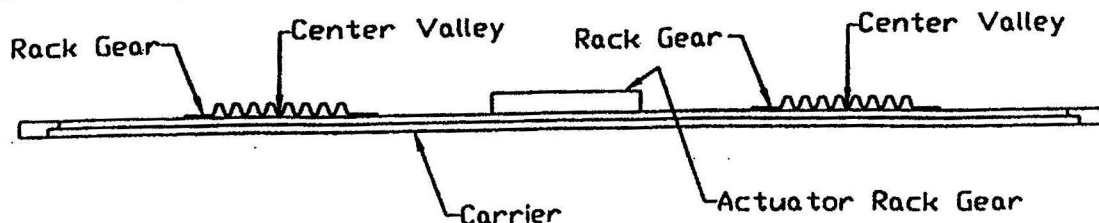

STEP 5

Place the side strap onto the tool, align all six holes. Using MM115 thread locker, from the center out insert and tighten the screws. Flip the tool over and do the same to the other side. Use extreme care not to move the carrier in this operation. Make sure that the carrier moves freely and is close fitting. A small hammer may be used to lightly tap the side straps until the carrier is close fitting, but not tight. If this does not work, repeat, beginning with step one through four.

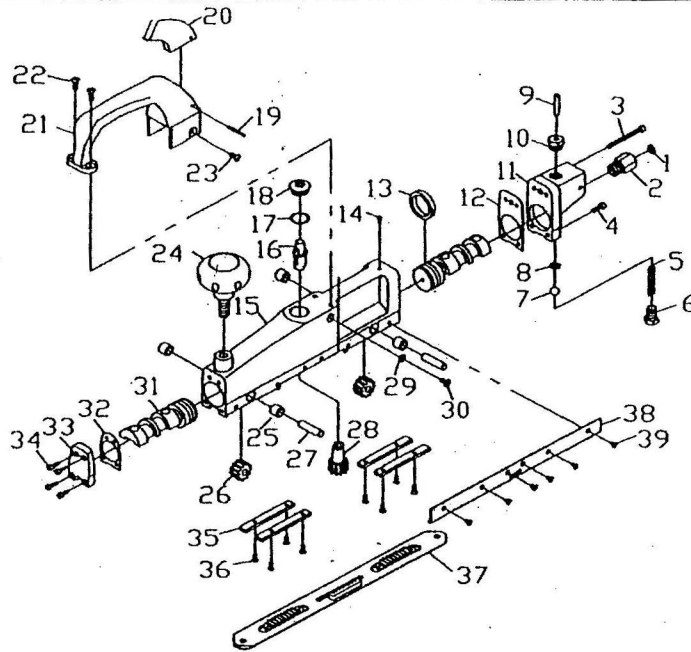

IMPORTANT
 OIL DAILY, Minimum of 10
 drops of Long Life Pneumatic
 or Lightweight Non-Detergent
 Oil into the Air Inlet.

Item	Part No.	Description	Qty.	Item	Part No.	Description	Qty.
1	51017	Inlet Screen	1	21	11100	Handle	1
2	31017-1	Inlet Bushing	1	22	11106	Screw	2
3	11003	Screw	2	23	11107	Screw	2
4	11002	Screw	2	24	11900 W	Knob Assembly	1
5	11009	Trigger Spring	1	25	11302 R	Needle Bearing	4
6	11004	Trigger Plug	1	26	11303 R	Pinion Gear	2
7	11007	Trigger Ball	1	27	11301	Dowel Pin	2
8	11011	Valve Seat	1	28	11700	Actuator	1
9	11006	Trigger Stem	1	29	10007	Washer	1
10	11005	Trigger Body	1	30	10002	Screw	1
11	10015 W	Rear Head	1	31	11200WA	Piston Assembly	2
12	10016 R	Rear Gasket	1	32	12003 R	Front Gasket	1
13	11204	Piston Ring	4	33	12001 W	Front Head	1
14	10003	Drive Screw	1	34	11002 R	Screw	4
15	10013WA	Body Assembly	1	35	12101 R	Bearing Strip	4
16	11801	J-Valve	1	36	12102 R	Screw	8
17	11803	O-Ring	1	37	11400WA	Carrier Assembly	1
18	11802	Oil Plug	1	38	11600 W	Side Strap	2
19	50001-1	Rollpin	1	39	11602 R	Screw	12
20	11103	Trigger	1				

NOTES:

PAPER SIZE: 2 3/4" X 17 1/2"
 SPEED RATING: 2400 SPM
 RATED AIR PRESSURE: 90 PSI
 AVG AIR CONSUMPTION: 4 CFM
 AIR INLET SIZE: 1/4" NPT
 HOSE SIZE: 3/8" ID

AVAILABLE EQUIPMENT

VIKING NO.	DESCRIPTION
V504	4" X 17" SANDING SHOE (KLIP TYPE)
V507	2 3/4" X 17" SANDING SHOE (STICK IT)
V509	VIKING PNEUMATIC OIL, 1-OZ.
V511	VIKING PNEUMATIC OIL, QUART
V512	VIKING PNEUMATIC OIL, 4-OZ.
V600	DUSTLESS KIT

IMPORTANT: To assure product safety and reliability, repairs maintenance and adjustments should be performed by Viking Air Tools, Inc., always using VIKING replacement parts.

**VIKING AIR TOOLS
 DUAL PISTON
 STRAIGHT LINE SANDER
 CATALOG NO. V100**

ITEM	PART NO.	DESCRIPTION	QTY
1-1	10015	HEAD, REAR ASSY	1
3	11002	SCREW HEAD	6
4	11008	ADAPTER	1
5	11003	SCREW, HEAD	2
6	11005	PLUG	1
7	11007	BALL, STEEL	1
8	11009	SPRING	1
9	11004	PLUG	1
10	11006	PIN, AIR VALVE	1
11	10016	GASKET, REAR	1
12-1	11100	HANDLE ASSY	1
14	11103	TRIGGER	1
15	30102	PIN	1
16	11106	SCREW, HANDLE FRT	2
17	11107	SCREW HANDLE, REAR	2
18-1	11200	PISTON SET	2
20	11204	RING, PISTON	4
21	11205	PLUG, FELT	4
23-1	11300	PINION, SHAFT BEARING	1
24	11301	SHAFT, BEARING	2
25	11302	BEARING, PINION	4
26	11303	GEAR, PINION	2
27-1	11400	CARRIER ASSY	1
29-1	V503	SHOE	1
30	11502	CLAMP, SHOE (TOP)	2
31	11503	CLAMP, SHOE (BOTTOM)	2
32	11504	CLIP, SHOE	1
33	11506	NUT, SHOE	2
34	15043	BOLT, SHOE	2
35	11508	PAD, CLIP-ON	1
	11510	PAD, PSA, 2.5	1
36-1	11600	STRAP	2
37	11602	SCREW, STRAP	12
38	11700	GEAR, ACTUATOR	1
39-1	11800	VALVE ASSY	1
40	11803	O-RING	1
41	11802	PLUG, VALVE	1
42	11801	VALVE	1
43	11900	KNOB	1
44-1	12001	HEAD, FRONT	1
45	12003	GASKET, FRONT	1
46	11002	SCREW	4
49	12101	BEARING STRIP	4
50	12102	SCREW, BEARING STRIP	8

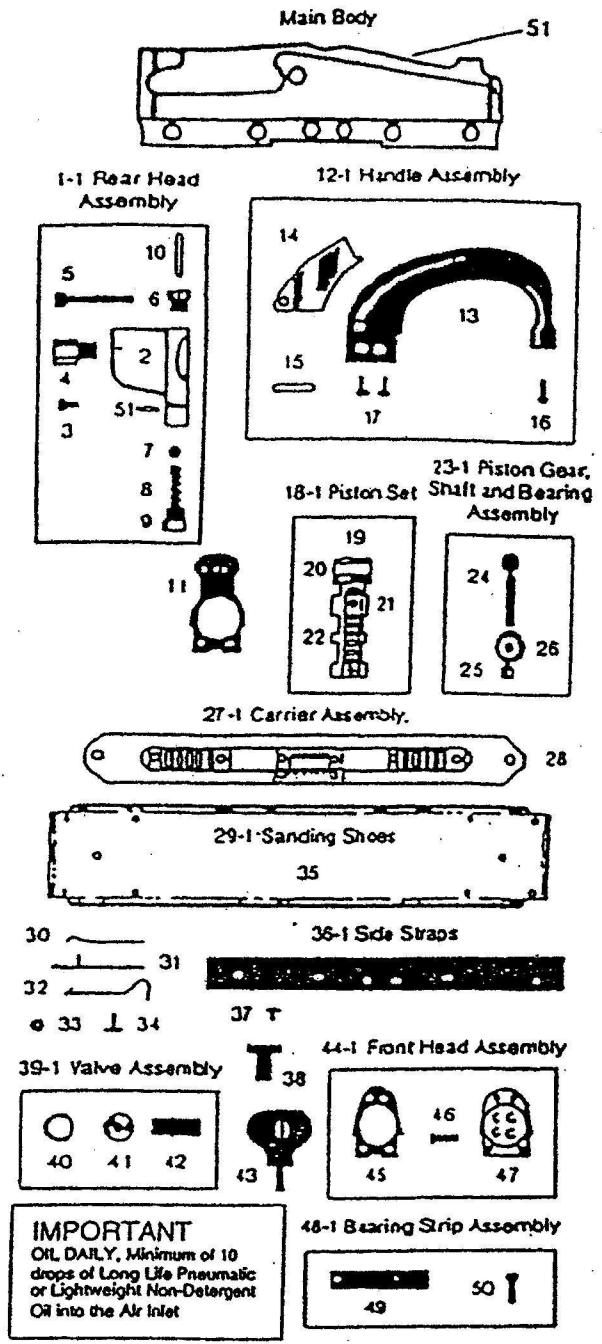

Installation Instructions

Viking V600 & V603

Dust Extraction Conversion Kit for V100 & V101

TOOLS AND MATERIALS REQUIRED:

#2 Phillips screwdriver, 3/8" - 7/16" wrench, 1/8" and 5/32" allen wrenches and a dry cloth.

Step 1. Remove old sanding pad from the tool to be converted to the dust extraction sander.

Step 2. Clean the bottom of sanding shoe carrier. **Important: Make sure that carrier is straight.**

Step 3. Attach dust extracting shoe (1), extraction opening (1A) on left side of tool, with the provided bolts (2), washers (3) and nuts (4). **For your safety: Place bolt heads through the top of carrier as shown to reduce pinch hazard on carrier.**

Step 4. Remove screws from the side of the sander body where indicated by arrows. Clean side strap surface.

Step 5. Place the tool on a flat surface (shoe down) and install dust extraction tube (5) with the provided screws (6).

Step 6. With light pressure, push down on extraction tube while tightening screws. The extraction tube will be in light contact with shoe surface. No visible gap should be apparent between tube and shoe. If a gap exists, push down a little harder while tightening the screws.

