

VIKING

AIR TOOLS

ABRASIVE FINISHING

Viking's earned reputation and position of continued leadership in the development of abrasive finishing tools allows us to offer a complete line of sanders & polishers that deliver unsurpassed power & performance, resulting in the perfect finish. Lightweight designs ensure they are comfortable and easy to operate.

Straight Line Sanders Removes Material Quickly / Smooth Operation / Ideal for Surface Preparation of Fiberglass, Sheet Metal, Steel, Body Putty or Wood / 1/4 NPT Air Inlet / 3/8" Min. Hose Size



V100 Dual Piston Straight Line Sander



V101 Single Piston Straight Line Sander

Model	SPM	CFM	Noise	Required Pressure	Adapter	Vibration	Weight	Type of Pad Supplied	Warranty
V100	2,400	4	91	90-100 PSI	1/4"	<2.5 M/S2	7-3/4"	2-3/4" x 16" Klip-on	2 yr.
V101	2,400	4	89	90-100 PSI	1/4"	<2.5 M/S2	6-1/2"	2-3/4" x 11" P.S.A.	2 yr.

Random Orbital Palm Sander Light Weight Aluminum Housing / Heavy Duty Motor (9,000 RPM, 1/4 HP) / One Piece Speed Control Lever / Reduced Sound From Rear-Exhaust Nozzle / Provides Higher Degree of Finishes On Metal, Wood & Composites / Non-Vacuum / 1 Year Warranty



VT4100 Random Orbital Palm Sander

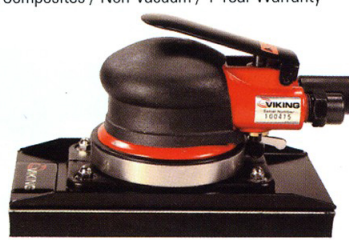

VT4101 Random Orbital Palm Sander

Model	CFM	Pad Size	Noise	Air Inlet	Min. Hose	Max. Pressure	Vibration	Height	Weight
VT4100	5	6"	89 dB	1/4 NPT	3/8"	90 PSI	<2.5 M/S2	3-1/2"	1.9 Lbs.
VT4101	5	3-3/4" x 7-1/4"	89 dB	1/4 NPT	3/8"	90 PSI	<2.5 M/S2	3-1/2"	1.9 Lbs.

Dual Action Orbital Sander Offers Unique Built-In Regulator for Variable Speed Control / 4 CFM / 1/4 NPT Air Inlet / 3/8" Min. Hose Size / 1/4" Adapter / <2.5 M/S2 Vibration



V201 8" Mudslinger Sander (Gear Driven)



V200 6" Dual Action Orbital Sander

Model	RPM	CFM	Pad Size	Noise	Required Pressure	Vibration	Weight	Type of Pad Supplied
V200	10,000	4	6"	78 dB	60 PSI	<2.5 M/S2	4.5 Lbs.	6" P.S.A.
V201	900	4	8"	87 dB	80 PSI	<2.5 M/S2	5.5 Lbs.	8" P.S.A.
VT200	10,000	4	6"	96 dB	90 PSI	3.6 M/S2	3.75 Lbs.	1 yr. Warranty

Belt Sanders Rear Exhaust Directs Air Away From Work Surface / Silencer Reduces Noise / Precision Air Motor With Exceptionally High Turning Force / Precision Ball Bearings For Longer Life / Built-In Speed Regulator / 360° Head Rotation / 1/4 NPT Air Inlet / 3/8" Min. Hose Size / 1 Year Warranty



VT4500 1/4" Belt Sander



VT4505 1" Belt Sander

Model	RPM	CFM	HP	Belt Size	Noise	Max. Pressure	Vibration	Length	Weight
VT4500	16,000	14.2	.37	1/4" x 13"	80 dB	85 PSI	3.8 M/S2	10-7/16"	2 Lbs.
VT4501	16,000	8	0.31	3/8" x 13"	89 dB	90 PSI	3.8 M/S2	11.4"	1.75 Lbs.
VT4503	16,000	9	0.42	3/4" x 20-1/2"	89 dB	90 PSI	3.1 M/S2	14.1"	2.6 Lbs.
VT4504	16,000	9	0.42	1/2" x 24"	89 dB	90 PSI	3.8 M/S2	16.9"	2.2 Lbs.
VT4505	12,000	24	0.7	1-3/16" x 21-1/4"	79 dB	85 PSI	3.1 M/S2	11-5/8"	5 Lbs.

High Speed Sander Offers Unique Built-In Regulator Providing Precise Speed Control / Compact / Light Weight Design / 1/4 NPT Air Inlet / 3/8" Min. Hose Size / 90 PSI Max Pressure



V320 5" High Speed Rotary Sander



VT4300 5" High Speed Sander

Model	RPM	CFM	HP	Pad Size	Noise	Adapter	Vibration	Length	Weight	Warranty
VT4300	16,000	5	0.3	5"	99 dB	3/8"	0.2 M/S2	5.9"	2.3 Lbs.	1 yr.
V320	20,000	4	0.5	5"	84 dB	1/4"	<2.5 M/S2	6.5"	2.25 Lbs.	2 yr.

Right Angle Sander / Polisher 1 HP Motor / 8 CFM Average Air Consumption / 1/4" NPT Air Inlet Size / 5/8"-11 Spindle Size / 7" Sanding Pad / Adjustable Speed Control / Unique Muffler Design / Standard Side handle Fits Left or Right Side



V716S Right Angle Sander
0-6,000 RPM Free Speed



V716P Right Angle Polisher
0-4,000 RPM Free Speed

SANDING SHOES



V502 Hook-It Type (for V100)
V503 Klip Type (for V100)
V507 Stick-It Type (for V100)



V514 Stick-It Type (for V101)
V515 Klip Type (for V101)
V516 Hook-It Type (for V101)

IMPACT WRENCHES *Built to deliver more value, higher productivity & long life in the toughest working environments*

Standard Duty Economical Rocking Dog Impact / Smooth Operation & Maximum Durability / Built-In Regulator with 4 Power Settings / Maximum Torque in Reverse Direction / Front & Rear Bumper Guards / One Hand Push Button Forward & Reverse / 1/4 NPT Air Inlet / 90 PSI Maximum Pressure / 1 Year Warranty



VT2000 1/2"

Model	Sq. Drive	RPM	CFM	Noise	Min. Hose	Torque Range	Length	Weight
VT2000	1/2"	7,000	16	92 dB	3/8" I.D.	230 ft. Lbs.	7"	4.8 Lbs.

Professional 4 Positive Power Settings in Forward / Maximum Torque in Reverse / Durable Pin Clutch Impact Mechanism / Ergonomic Contoured Elastomer Handle Grip / Handle Exhaust / 360° Air Inlet Swivel (Except VT2100) / Push Button Forward & Reverse For Single Hand Operation / Easy Touch Trigger / 1/4 NPT Air Inlet / 90 PSI Maximum Pressure / 1 Year Warranty



VT2100 3/8" | VT2101 1/2" | VT2102 3/4"

Model	RPM	CFM	Sq. Drive	Noise	Min. Hose	Torque Range	Length	Weight	Vibration
VT2100	9,000	13.4	3/8"	95 dB	3/8" I.D.	134-160 ft. Lbs.	6-1/2"	2.8 Lbs.	2.6 M/S2
VT2101	8,000	13.6	1/2"	95 dB	3/8" I.D.	241-400 ft. Lbs.	7.48"	4.6 Lbs.	3.2 M/S2
VT2102	4,500	20	3/4"	98 dB	1/2" I.D.	700-1000 ft. Lbs.	9.3"	8.8 Lbs.	4.4 M/S2

Heavy-Duty Twin Hammer Impact Mechanism Delivers Balanced Blows for Maximum Power / Adjustable Power Output in Forward & Reverse / Handle Exhaust / Two-Piece Housing for Easy Service & Operator Convenience / Easy Touch Trigger Provides Greater Control & Operator Comfort / 3/8" Minimum Hose Size / 90 PSI Maximum Pressure / 1 Year Warranty



VT2200 3/8" | VT2201 1/2" | VT2202 3/4"

Model	RPM	CFM	Sq. Drive	Noise	Air Inlet	Torque Range	Length	Weight	Vibration
VT2200	10,000	2.8	3/8"	88 dB	1/4 NPT	200 ft. Lbs.	6-3/8"	3.5 Lbs.	3.1 M/S2
VT2201	7,000	4.6	1/2"	88 dB	1/4 NPT	450 ft. Lbs.	7-1/4"	5.6 Lbs.	3.6 M/S2
VT2202	5,000	7.2	3/4"	89 dB	3/8 NPT	750 ft. Lbs.	9-5/8"	8.75 Lbs.	5.3 M/S2

Composite Heavy-Duty Twin Hammer Impact Mechanism Delivers Balanced Blows for Maximum Power / Three Power Settings in Forward / Maximum Torque in Reverse / Extra Strong, Lightweight Construction / Composite Material Housing with Rubber Coated Steel Hammer Case / Handle Exhaust / Two-Piece Housing for Easy Service / Easy Touch Trigger / 3/8" Minimum Hose Size / 90 PSI Maximum Pressure / 1 Year Warranty



VT2200C 3/8" | VT2201C 1/2" | VT2202C 3/4"

Model	RPM	CFM	Sq. Drive	Noise	Air Inlet	Torque Range	Length	Weight	Vibration
VT2200C	12,000	7.2	3/8"	87 dB	1/4 NPT	240-280 ft. Lbs.	6-1/2"	2.6 Lbs.	5.3 M/S2
VT2201C	7,500	7.2	1/2"	87 dB	1/4 NPT	900 ft. Lbs.	7-5/8"	4.5 Lbs.	5.3 M/S2
VT2202C	5,500	7.2	3/4"	88 dB	3/8 NPT	950 ft. Lbs.	9-1/16"	7.65 Lbs.	5.3 M/S2

Angle Head Twin Hammer Impact Mechanism / Lever Throttle for Easy Operation / Adjustable Torque Settings in Forward or Reverse / One Piece Anvil is Manufactured of Alloy Nickel Chromium & Molybdenum Steel / 90 PSI Maximum Pressure / 1 Year Warranty



VT2500 3/8" | VT2501 1/2" | VT2502 1/2"

Model	RPM	CFM	Sq. Drive	Noise	Air Inlet	Min. Hose	Torque Range	Length	Weight
VT2500	6,500	3	3/8"	80 dB	1/4 NPT	3/8" I.D.	74 ft. Lbs.	10-1/2"	3.3 Lbs.
VT2501	6,500	3	1/2"	80 dB	1/4 NPT	3/8" I.D.	74 ft. Lbs.	10-1/2"	3.3 Lbs.
VT2502	5,000	3	1/2"	80 dB	1/4 NPT	3/8" I.D.	140 ft. Lbs.	12"	4 Lbs.
VT2503	8,500	3	1/2"	80 dB	1/4 NPT	3/8" I.D.	100 ft. Lbs.	10-1/2"	3.8 Lbs.

AIR RATCHETS *Built with a heat-treated, hardened ratchet yoke to maintain peak performance and prevent "spreading".*

Standard Duty Planetary Gear Design / Lever Throttle for Easy Operation & Enhanced Speed Control / Great for Hard-to-Reach Areas / Ergonomic Square Handle Design for Positive Grip / 1/4 NPT Air Inlet / 90 PSI Maximum Pressure / 1 Year Warranty

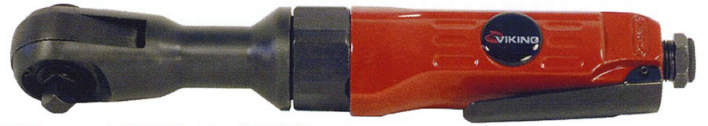

VT1000 1/4" | VT1001 3/8" | VT1003 1/2"

Model	Sq. Drive	RPM	CFM	Noise	Min. Hose	Torque Range	Length	Weight
VT1000	1/4"	240	12	90 dB	1/4" I.D.	20 ft. Lbs.	8-1/4"	1.5 Lbs.
VT1001	3/8"	150	14	90 dB	3/8" I.D.	45 ft. Lbs.	10"	2.75 Lbs.
VT1003	1/2"	150	14	90 dB	1/2" I.D.	45 ft. Lbs.	10"	2.8 Lbs.

Mini Durable Ratchet Head / Variable Speed Throttle Provides Precise Control / Ball & Needle Bearing Construction for Long Life / Compact & Lightweight / 1/4 NPT Air Inlet / 90 PSI Maximum Pressure / 1 Year Warranty



VT1100 1/4" | VT1101 3/8"

Model	Sq. Drive	RPM	CFM	Noise	Min. Hose	Torque Range	Length	Weight
VT1100	1/4"	230	5	87 dB	1/4" I.D.	25 ft. Lbs.	6-1/2"	1 Lbs.
VT1101	3/8"	230	5	87 dB	1/4" I.D.	25 ft. Lbs.	6-1/2"	1 Lbs.

Heavy-Duty No Spread Ratchet Head / Ergonomic Comfort Grip on Models VT1202/VT1203 / Compact Head Design Allows Greater Flexibility in Tight Areas / Variable Speed Throttle / 1/4 NPT Air Inlet / 90 PSI Maximum Pressure / 1 Year Warranty



VT1202 3/8" | VT1203 1/2" | VT1204 1/2"

Model	Sq. Drive	RPM	CFM	Noise	Min. Hose	Torque Range	Length	Weight
VT1202	3/8"	160	7	95 dB	3/8" I.D.	75 ft. Lbs.	9"	2.6 Lbs.
VT1203	1/2"	160	7	95 dB	3/8" I.D.	75 ft. Lbs.	9"	2.6 Lbs.
VT1204	1/2"	150	5	98 dB	3/8" I.D.	90 ft. Lbs.	14-3/8"	4.4 Lbs.

Torque Tamer IMPACT WRENCH



VT700K Torque Tamer

Designed for the Professional Tire Installer

- Light-weight ergonomic design reduces fatigue
- Powerful enough to remove the most stubborn lug nuts
- Extended 2" anvil
- 3 forward power settings avoids over-torque
- Twin hammer impact mechanism delivers balanced blows for maximum power
- Easy touch trigger provides greater control & operator comfort
- Two piece housing offers easy service
- 1 year warranty
- 1/2" Sq. Drive / 1/4" Air Inlet / 90 PSI Air Pressure / 50-600 ft. Lbs Forward Torque / 900 ft. Lbs. Reverse Torque / 7,500 RPM

Includes 3 Free Flip Sockets & Airtool Oil!



VIKING

DIE GRINDERS

Viking has more models to allow you to own the right tool for the right job at the most cost effective price.

Straight / Angle Superior Performance in a Variety of Applications / Many Sizes to Meet Any Need / Variable Speed Operation with Safety Throttle Lever / 4 CFM / 1/4 NPT Air Inlet / 3/8" Minimum Hose Size / 90-100 PSI Maximum Pressure

V361DC & V363DC Available with Chuck



V324 1/4" Collet, Heavy-Duty, Straight



V362 1/4" Collet, Mini, Angle

Model	RPM	Type	HP	Collet/Chuck	Noise	Vibration	Exhaust	Length	Weight
V361	22,000	Straight	0.4	1/4"	86 dB	2.5 M/S2	Front	6-1/4"	1-3/4 Lbs.
V361DC	22,000	Straight	0.4	3/8" Ch.	86 dB	2.5 M/S2	Front	6-1/4"	1-3/4 Lbs.
V362	20,000	Angle	0.4	1/4"	86 dB	2.5 M/S2	Front	6"	1 Lbs.
V363	22,000	Straight	0.4	1/4"	86 dB	2.5 M/S2	Front	6-7/8"	1 Lbs.
V363DC	22,000	Straight	0.4	3/8" Ch.	86 dB	2.5 M/S2	Rear	6-7/8"	1 Lbs.
V364	15,000	Angle	0.4	1/4"	86 dB	2.5 M/S2	Rear	6-3/4"	1-1/3 Lbs.
V323	20,000	Straight	0.5	3/8" Ch.	82 dB	2.5 M/S2	Rear	7-1/4"	1-1/4 Lbs.
V324	20,000	Straight	0.5	1/4"	82 dB	<2.5 M/S2	Rear	7-3/8"	1-1/4 Lbs.

Straight / Angle: Value Superior Performance in a Variety of Applications / Many Sizes to Meet Any Need / 1/4 NPT Air Inlet / 3/8" Minimum Hose Size / 90 PSI Maximum Pressure / Rear Exhaust (Except VT3003A) / 1 Year Warranty



VT3000 1/4" Collet, Lightweight, Straight



VT3001A Gearless 105° Angle

Model	RPM	Type	CFM	HP	Collet	Noise	Vibration	Length	Weight
VT3000	Straight	25,000	14	0.3	1/4"	93 dB	5.4 M/S2	6-5/16"	1.1 Lbs.
VT3000A	Angle	20,000	14	0.3	1/4"	93 dB	5.4 M/S2	6-5/16"	1.65 Lbs.
VT3001	Straight	22,000	4	0.3	1/4"	93 dB	5.4 M/S2	6-3/4"	1.6 Lbs.
VT3001A	105° Angle	25,000	4	0.3	1/4"	83 dB	2.0 M/S2	6-1/8"	1.6 Lbs.
VT3003A	Angle	20,000	12	0.3	1/4"	86 dB	3 M/S2	5"	1.2 Lbs.
VT3005	Straight	22,000	4	0.3	1/4"	93 dB	5.4 M/S2	7"	1.65 Lbs.

Micro Twist Throttle with Variable Speed Control / Cylinder is Made of Special Heat Treated Alloy Steel / Internal Surfaces Precision Ground / Heavy-Duty High Speed Bearings / Includes 52" Air Hose & Fittings / 1/4 NPT Air Inlet / 3/8" Minimum Hose Size / 90 PSI Maximum Pressure



VT3400 High Speed Micro

Model	RPM	CFM	HP	Collet	Noise	Vibration	Length	Weight	Warranty
VT3400	60,000	2.25	1	1/8"	81 dB	4 M/S2	6"	0.8 Lbs.	1 yr.

Extended Industrial Duty / Precision Machined & Hardened Steel Gears / Air Motor with Exceptionally High Turning Force / High Quality Ball Bearings / Safety Throttle Lever / Ergonomic Square Handle / Rear Exhaust / 3/8" Minimum Hose Size / 90 PSI Maximum Pressure



VT3002E Extended

Model	RPM	CFM	HP	Collet	Noise	Air Inlet	Vibration	Length	Weight	Warranty
VT3002E	22,000	4	0.3	1/4"	93 dB	1/4"	5.4 M/S2	13"	2.8 Lbs.	1 yr.
VT3004E	4,500	4	0.3	1/4"	80 dB	1/4"	5.4 M/S2	8"	2.31 Lbs.	yr.
VT3009E	22,000	4	0.6	1/4"	93 dB	1/4"	5.4 M/S2	13"	2.68 Lbs.	1 yr.
VT3010E	25,000	3.5	0.6	1/4"	93 dB	1/4"	5.4 M/S2	10-1/4"	1.41 Lbs.	1 yr.

Pneumatic Oil

V509 1 oz. / V512 4 oz. / V511 32 oz.



- Specially formulated for pneumatic tools, in-line oilers & lubricators
- High and low temperature resistant
- Prevents rusting by throwing off moisture when present
- Virtually eliminates lubrication blow-out due to air pressure
- Provides positive lubrication for smooth starting and longer life
- Will not harm O-rings and seals
- Aids in dissolving gums & sludges that cut down tool speed & reduce power output
- Case of 12

GRINDERS

Viking offers a great selection of industrial duty grinders to choose from. Designed to handle increased precision and production efficiently & easily.

Standard-Duty Precision Air Motor With Exceptionally High Turning Force / Sealed Ball Bearing Motor / Compact Body / Front Exhaust / Safety Locking Lever With Variable Throttle / Removable Side Handle / Includes Guard, Hex Wrenches & Spanner / Wheels Not Included / 100 PSI Maximum Pressure / 1 M/S2 Vibration / 1 Year Warranty



VT3104 4"



VT3105 4.5"/5"

Model	RPM	CFM	HP	Wheel	Noise	Air Inlet	Min. Hose	Arbor	Length	Weight
VT3104	11,000	6	0.75	4"	95 dB	1/4"	3/8"	3/8-24"	9"	4 Lbs.
VT3105	11,000	6	0.75	4.5"/5"	94 dB	1/4"	3/8"	5/8-11"	9"	4.6 Lbs.
VT3107	7,000	9	1	7"	96 dB	3/8"	1/2"	5/8-11"	13-1/2"	6.6 Lbs.

Heavy-Duty Cast Construction / Speed Regulating Valve / Vibration-Dampening Side Handle / Lock Off Safety Lever / Controlled Variable Throttle Lever / Adjustable Exhaust Direction / Wheels Not Included / 90 PSI Maximum Pressure / 0.6 M/S2 Vibration / 1 Year Warranty



VT3205 4.5"/5"



VT3207 7"

Model	RPM	CFM	HP	Wheel	Noise	Air Inlet	Min. Hose	Arbor	Length	Weight
VT3204	13,600	34	0.9	4"	95 dB	1/4"	3/8"	3/8-24"	9-11/16"	4.6 Lbs.
VT3205	10,900	34	0.9	4.5"/5"	94 dB	1/4"	3/8"	5/8-11"	9-11/16"	4.9 Lbs.
VT3207	7,600	57	1.2	7"	96 dB	3/8"	1/2"	5/8-11"	11-13/16"	8.8 Lbs.

Vertical, Heavy-Duty Side Exhaust / Safety Throttle Trigger / Hardened Steel Motor Parts / Over Speed Auto Shut-Off / High Force Corrosion-Resistant Governor, Unitized Motor Design With Hardened Steel End Plates & Liner To Maintain Constant Speed Under Load / Can Be Fitted With Grinding Wheels & Wire Brushes / Wheels Not Included / 90 PSI Maximum Pressure / 1/2" Min. Hose Size / 1 Year Warranty



VT3507 7"

Model	RPM	CFM	HP	Wheel	Noise	Air Inlet	Arbor	Vibration	Length	Weight
VT3507	7,000	36	2.5	7"	96 dB	1/2"	5/8-11"	3.6 M/S2	7-1/4"	10.5 Lbs.
VT3509	6,000	36	3	9"	95 dB	1/2"	5/8-11"	4.1 M/S2	7-1/2"	12.75 Lbs.

DRILLS

Our exceptional engineering & construction provide innovative designs with a focus on ergonomics have resulted in drills that are light weight, balanced and powerful.

Pistol Grip, Straight & Angle One Hand Quick Reverse Lever (on reversible drills) / Elastomer Handle Grip (Pistol) / Heavy Duty Ball & Needle Bearing Construction / Planetary Gear Reduction Balances Drilling Load & Maximizes Performance / Precision Air Motor with Exceptionally High Turning Force / 3/8" Min. Hose Size / 90 PSI Maximum Pressure / 1 Year Warranty



VT5000 3/8" Reversible, Pistol Grip



VT5006 1/2", Pistol Grip



VT5003 3/8" Straight



VV0408 3/8" Reversible Angle

Model	Type	RPM	CFM	HP	Chuck Cap	Noise	Air Inlet	Vibration	Length	Weight
VT5000	Pistol	1,800	4	.33	3/8"	85 dB	1/4"	<2.5 M/S2	7"	2.4 Lbs.
VT5001	Pistol	2,600	4	.33	3/8"	90 dB	1/4"	<2.5 M/S2	7-3/4"	2.4 Lbs.
VT5006	Pistol	500	4	.50	1/2"	89 dB	1/4"	<2.5 M/S2	9-1/2"	4 Lbs.
VT5007	Pistol	800	4	.50	1/2"	89 dB	1/4"	<2.5 M/S2	7-1/2"	4 Lbs.
VT5002	Straight	2,600	4	.33	3/8"	90 dB	1/4"	<2.5 M/S2	8-1/2"	2 Lbs.
VT5003	Straight	4,500	4	.33	3/8"	90 dB	1/4"	<2.5 M/S2	8-3/4"	2.4 Lbs.
VV0408	Angle	1,500	4	.33	3/8"	94 dB	1/4"	<2.6 M/S2	7"	2.4 Lbs.
VT5005A	Angle	1,900	4	.33	3/8"	92 dB	1/4"	<2.6 M/S2	8"	2.4 Lbs.

PERCUSSIVE TOOLS

Viking offers a variety of sizes, capacities and accessories built durably to ensure long life under tough operating conditions. Viking's line of percussive tools has a constant duty rating and are ideally suited for multiple applications on any surface. We build them to work hard on any job.

Air Hammers Patented Vibration Dampening System / Easy Touch Trigger / Special Heat Treated Hardened Steel Barrel & Piston / Standard Spring Retainer / Elastomer Handle Grip / 3/4" Bore Size / 1/4 NPT Air Inlet / 3/8" I.D. Min. Hose / 90 PSI / 1 Year Warranty



VT6006 Vibration Damped

Chipping Hammers Outside Trigger & Open Hand Handle Design / Heavy-Duty Hammer / Alloy Steel Piston & Barrel / 1-1/8" Bore Size / Round Shank / 3/8 NPT Air Inlet / 1/2" I.D. Min. Hose / 90 PSI / 1 Year Warranty



VT6102 2"

Flux Scaler Heat Treated Barrels & Pistons / Quick Change Type Chisel Retainer / Comfortable Lever Throttle / Comes Standard With Chisel / Elastomer Handle Grip (Pistol) / 90 PSI / 1 Year Warranty

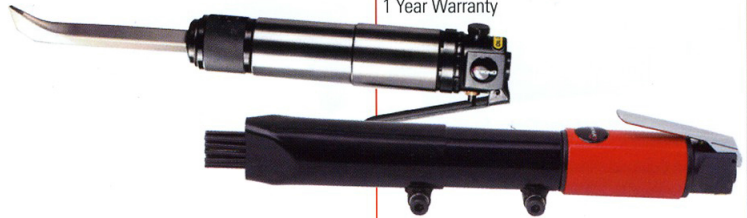

VT6009 Straight Handle

Needle Scaler Auto-Adjusts to Any Surface Contour / Cleans Welds, Castings, Brick, Stone Work, Concrete & Steel Plates / Heat Treated Barrels & Pistons / Chrome Vanadium SCM-4 Needles / 19 Needle (.12" x 7") / 90 PSI / 1 Year Warranty

VNT1851 Heavy Duty

Model	Type	RPM	CFM	Stroke	Blows	Shank	Noise	Vibration	Length	Weight
VT6000	Medium Air	-	10	2-5/8"	3000	.401"	101 dB	10.24 M/S2	7-1/2"	3 Lbs.
VT6001	Heavy Air	-	10	2-5/8"	3000	.401"	110 dB	5.1 M/S2	6-3/4"	3.6 Lbs.
VT6005	Damped Air	-	10	3"	2500	.401"	113 dB	3.5 M/S2	6-1/2"	5.5 Lbs.
VT6006	Damped Air	-	10	3-3/4"	2100	.401"	116 dB	3.5 M/S2	11"	6.2 Lbs.
VT6102	Chipping	2,400	30	2"	2,400	.680"	115 dB	8.6 M/S2	12-7/8"	15 Lbs.
VT6103	Chipping	1,920	31	3"	1,920	.680"	120 dB	13.9 M/S2	14-7/8"	16 Lbs.
VT6104	Chipping	1,500	33	4"	1,500	.680"	119 dB	16.3 M/S2	16-1/8"	17.8 Lbs.

Model	Type	RPM	CFM	Stroke	Noise	Air Inlet	Min. Hose	Vibration	Length	Weight
VT6008	Flux, Pistol	3,000	10	5/8"	107 dB	1/4"	3/8" I.D.	8.7 M/S2	10"	3.6 Lbs.
VT6009	Flux, St.	4,400	10	7/8"	101 dB	1/4"	3/8" I.D.	14.5 M/S2	16.1"	3.7 Lbs.
VT6200	Needle, St.	4,400	10	-	104 dB	1/4"	3/8" I.D.	10.2 M/S2	16.14"	5.9 Lbs.
VT6202	Needle, Pistol	3,700	10	-	107 dB	1/4"	3/8" I.D.	8.7 M/S2	10"	6.2 Lbs.
VNT1851	Needle, St.	3,700	10	-	104 dB	1/4"	3/8" I.D.	9 M/S2	14.75"	5.72 Lbs.

CUTTING TOOLS

Viking offers a versatile range of shears, saws, nibblers and nippers ready to handle any application and designed to cut or trim a wide range of materials. Ultra light weight construction with low vibration, all of our air cutting tools are ergonomically designed for comfort, control and easy handling.

Cut-Off Saw 3" Heavy Duty Wheel / Direct Drive Motor / Low Vibration / 1/2 HP / 3/8" I.D. Min. Hose / 90 PSI Required Pressure



V325 Mini Cut-Off Saw

Circular Saw Adjustable Cutting Depths Capability / Lock-Off Safety Throttle / Heavy-Duty Motor & Geared Drive / Metal Blade Guard / Accepts 2" Capacity Blade / Light Weight / VT7502 - Ideal For Cutting Ferrous Metal / VT7503 - Ideal For Cutting Non-Ferrous Metal, Wood, Fiberglass And Composites / 1/4 NPT Air Inlet / 3/8" I.D. Min. Hose / 100 PSI Max. Pressure / 1 Year Warranty



VT7503 2" Circular Saw

Model	Type	RPM	CFM	Noise	Air Inlet	Adapter	Vibration	Length	Weight
V325	Cut-Off	20,000	4	92 dB	1/4 NPT	1/4"	<2.5 M/S2	7-3/8"	1-1/2 Lbs.
VT7502	Circular	620	4	94 dB	1/4 NPT	-	3.7 M/S2	9-5/8"	2.3 Lbs.
VT7503	Circular	3,500	4	94 dB	1/4 NPT	-	3.7 M/S2	9-5/8"	2.3 Lbs.

Reciprocating Saws Positive Blade Retention / Adjustable Guard Guide / Kick-Off Throttle & Built-In Regulator / High Performance Motor / 5,000 Strokes Per Minute / Rear Exhaust / Built-In Silencer / Light Weight, Slim Design / Safety Throttle Speed Lever / 16 Gauge Metal Capacity / 90 PSI Max. Pressure / 1 Year Warranty



VT7500 Reciprocating Saw & File
(One tool for both sawing and filing)

Model	Type	RPM	CFM	Stroke	Noise	Air Inlet	Min. Hose	Vibration	Length	Weight
VT7500	Reciprocating	5,000	4	3/8"	90 dB	1/4 NPT	3/8"	45 M/S2	9.8"	2.8 Lbs.
VT7501	Reciprocating	9,000	6.5	3/8"	95 dB	1/4 NPT	3/8"	51 M/S2	9.5"	1.75 Lbs.
VT7000	Nibbler	2,900	7	-	90 dB	1/4 NPT	3/8"	5.9 M/S2	7"	2.2

Shears In-Line / Cuts Sheet Steel Up to 18 Gauge / Removes 1/4" Strip of Material / 1/2 HP



VBS18 Pistol Grip Blade Shear

Nibblers Access Cap / Speed Regulator / Ball Bearing Construction / Cuts Tight 3/8" Radius / 18 Gauge Metal Capacity / 90 PSI Max. Pressure / 1 Year Warranty



VT7000 Nibbler

SPECIALTY TOOLS

Punch / Flange Unique 2-in-1 Metal-working Tool / Head Swivels 360° / Insulated Handle / Comfortable Level Throttle / Crimps Up to 14 Gauge (.075") Sheet Steel or Punches Clean Holes (3/16") for Welding Applications / Muffled Handle Exhaust / 90 PSI Max. Pressure



VT8510 Punch / Flange Tool

Windshield Knife

Adjustable Oscillation / 2-1/8" Offset Blade / Rear Exhaust with Built-In Silencer / Well Balanced / Easy Blade Replacement / 90 PSI Max. Pressure



VT8520 Windshield Knife

Model	RPM	CFM	Noise	Air Inlet	Min. Hose	Vibration	Length	Weight	Warranty
VT8510	-	2.9	80 dB	1/4 NPT	3/8" I.D.	<2.5 M/S2	9-1/4"	4.6 Lbs.	1 yr.
VT8520	20,000	7	90 dB	1/4 NPT	3/8" I.D.	.9 M/S2	9.7"	3 Lbs.	1 yr.

VT9800 Electronic Ear Muffs

Volume control permits adjustment from maximum amplification to total shut off, with variation from active communication to passive hearing protection.

Key Features:

- Active Volume Hearing Function
- LED Power Indicator
- Allows user to listen to surroundings
- Boosts weak sounds
- Attenuates loud, harmful noise over 85db
- Improves working environment for the user
- Allows normal communication with headset on
- Requires 2 AA batteries (not included)



VT855 Air Hose Reel

This versatile all-steel unit mounts anywhere, and is easily installed. It features a spring tension brake to control rotation, and holds 100 feet of 5/8" hose or 50 feet of 1" hose.

- Includes 50' 3/8" Air Hose



Air Amplifier DRYING SYSTEM

VT9804 Air Amplifier Drying System Includes Stand, 2 Air Amplifiers, Swivel Stand & Coiled Hose

- Accelerates drying of painted surface
- Shorter booth times
- Lower investment costs
- Simple to use
- Universal application
- Portable design
- Corrosion resistant polished chrome
- 1 year warranty

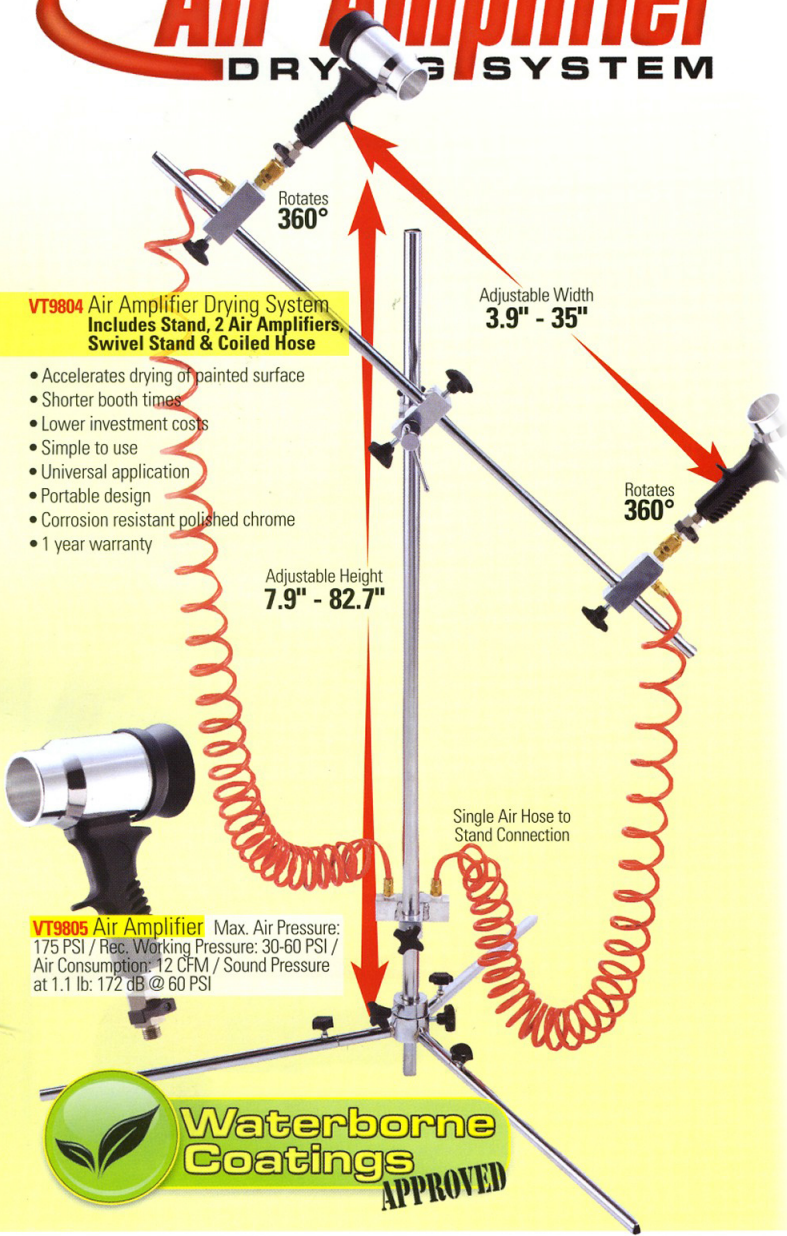

Adjustable Height
7.9" - 82.7"

Adjustable Width
3.9" - 35"

Single Air Hose to
Stand Connection

VT9805 Air Amplifier Max. Air Pressure:
175 PSI / Rec. Working Pressure: 30-60 PSI /
Air Consumption: 12 CFM / Sound Pressure
at 1.1 lbs: 172 dB @ 60 PSI



Wonder Gun VACUUM & BLOWER KIT

VT9806 Two-Way Wonder Gun Vacuum & Blower Kit
Includes: Extension Tube, Rotatable Brush,
Flexible Extension Hose, Crevice Tool,
Orifice Tool, Thumb-Grip Clamp and Dust Bag

- Two-way function meets vacuuming and blowing needs
- Lightweight, composite construction
- Perfect for use in media installation shops
- Ergonomic grip pistol style handle
- 1.47 lbs / 5.7" L / Ave. Air Consumption: 3.36 CFM / 1/4" Air Inlet / 5/16" Min. Hose Size



Photographic or typographic errors are unintentional and subject to correction. Due to the nature of printing and our evolving production, product colors may vary the actual product.

TAPPING

Arm Ideal for all general purpose tapping from small to medium size taps in mild steel (7/16" [5/16" for VT700] max. capacity or 1/2" [7/16" for VT700] in aluminum). Arm is equipped with lubricated for life bearings at all the swivel points, provides "weightless" operation and permits the operator to bring the tap to the hole with ease.

Increased Efficiency Operator brings the tap to the work utilizing the efficiency of bearings at all swivel points versus positioning a part under a spindle.

Ergonomically Correct Operator benefits from improved ergonomics and proper tool handling. The ergonomically-correct design absorbs the tapping torque reducing the strain on the operators hand, wrist and arm.

Increased Productivity Tapping cycle starts at the correct speed and can go direct to reverse at the desired depth.

Maximum Quality The tap holder floats in the machine, allowing the tap to precisely follow the hole without the influence of the spindle. With this "float", typically Viking Parallel Arm tapped holes produce higher quality threads that permit less than a quarter turn on a No-Go Gauge.

Never Break a Tap Again The clutch built into the tap holder "clicks" when the tap bottoms, hits interference, or begins to dull.

* Tap holders sold separately

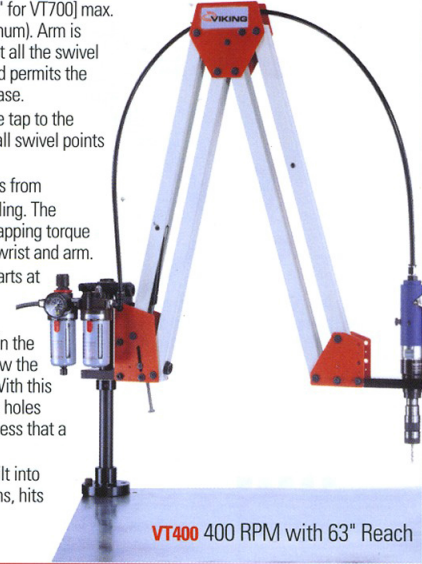

VT400 400 RPM with 63" Reach

Pistol Grip

Rapid Reverse / 1/8"-1/2"
Capacity / Adjustable Side Handle / Quick
Change Tooling Adapter / Precision Machined
& Hardened Gear Reduction / Heavy Duty Ball
Bearing Construction / Precision Air Motor
With Exceptionally High Turning Force /
.50 HP / 2.6 Lbs. / 80 dB / 1/4 NPT Air Inlet /
3/8" I.D. Min. Hose Size / 90 PSI Max. Pressure /
.25 M/S² Vibration / Tap holders sold separately



VT5500 1/2" Pistol Grip

Model	Type	RPM	CFM	Noise	Air Inlet	Min. Hose	Torque @ 90 PSI	Arm Reach / Length	Warranty
VT400	Parallel Arm	400	24	-	3/8 BSPP	3/8" I.D.	27	63"	1 yr.
VT700	Parallel Arm	700	24	-	3/8 BSPP	3/8" I.D.	16	63"	1 yr.
VT5500	Pistol Grip	150	27	80 dB	1/4 NPT	3/8" I.D.	45-145	7-1/2"	1 yr.

AIR SCREWDRIVERS

Deliver exceptional accuracy, consistent speed & torque combined with the latest ergonomics.

Pistol Grip & Straight

Torque Adjusting Cushion Clutch /
Planetary Gear Reduction / Precision Air
Motor with Exceptionally High Turning
Force / Heavy-Duty Ball & Needle Bearing
Construction / Elastomer Handle Grip (Except
Straight) / Easy Touch Variable Speed Trigger /
One Hand Quick Reverse Lever / Quick Change
Hex Collet / 1/4" Chuck Cap / 1/4 NPT Air Inlet /
3/8" Minimum Hose (Except VT5213 is 1/4") /
90 PSI Maximum Pressure / 1 Year Warranty
• Torque spring sold separately.



VT5203 with Adjustable Clutch

Model	Type	RPM	CFM	HP	Noise	Torque Range	Length	Weight	Vibration
VT5201	Adjustable	1,800	4	3.3	86 dB	45-115 in. Lbs.	7"	2.6 Lbs.	-
VT5202	Adjustable	800	4	3.3	86 dB	45-145 in. Lbs.	8-1/2"	2.6 Lbs.	9.2 M/S ²
VT5203	Adjustable	1,800	4	3.3	86 dB	45-115 in. Lbs.	7"	2.6 Lbs.	4.6 M/S ²
VT5212	Adjustable*	1,100	4	-	86 dB	13-30 in. Lbs.	8-1/8"	2.4 Lbs.	<0.8 M/S ²
VT5204	Adjustable	800	4	.33	86 dB	45-145 in. Lbs.	8-1/2"	2.6 Lbs.	9.2 M/S ²
VT5205	Positive	1,800	4	.33	91 dB	115 in. Lbs.	7"	2.6 Lbs.	.3 M/S ²
VT5206	Positive	800	4	.33	86 dB	145 in. Lbs.	8-1/2"	2.6 Lbs.	.25 M/S ²

VT5210 Straight, Torque Control

Model	Type	RPM	CFM	HP	Noise	Torque Range	Length	Weight	Vibration
VT5200	Adjustable	1,800	4	3.3	95 dB	45-115 in. Lbs.	10"	2.6 Lbs.	3.8 M/S ²
VT5213	Adjustable*	2,000	4	-	87 dB	13-30 in. Lbs.	8"	1.2 Lbs.	<0.8 M/S ²
VT5210	Torque Con.**	1,000	4	.33	87 dB	3.5-16.5 ft. Lbs.	10"	2.6 Lbs.	<0.8 M/S ²
VT5211	Torque Con.	1,100	4	.33	86 dB	13-30 ft. Lbs.	8-1/8"	2.4 Lbs.	<0.8 M/S ²

*Industrial **Pistol Grip

Photographic or typographic errors are unintentional and subject to correction. Due to the nature of printing and our evolving production, product colors may vary the actual product.

Check out the collection of air sanders and polishers we offer.