

## 702576 Aluminium Gravity Feed Cup (900cc)



**Important: Before using this equipment, read all safety precautions and instructions. Keep for future use.**

### WARNING

**Halogenated Hydrocarbon Solvents — for example: 1,1,1-Trichloroethane and methylene chloride can react with the aluminium in this cup and cause an explosion hazard. Read the data sheet for the material you intend to spray. Do not use spray materials containing these solvents with this cup.**

### DESCRIPTION

The cup is constructed from durable aluminium to provide trouble-free operation. The cup insert is electroless nickel plated brass. The disposable cup lid is recyclable and is constructed with recycled polyethylene. The lid has a unique drip check to prevent paint from dripping out of the vent in the lid.

### ASSEMBLY OF CUP TO GUN

1. Place filter (3) in cup outlet, if desired. See cup drawings.
2. Place cup gasket (4) in the fluid inlet of the gun body, if desired. See cup drawings.
3. Assemble cup to gun and tighten hand tight.

### FILLING WITH PAINT

Fill the cup with paint to within 20mm (3/4") from the top. **Do not overfill.**

### INSTALLING THE LID

Place plastic lid on the top of the cup, and **push in the centre of the lid to assemble lid.** Fold vent cap and push onto centre portion of lid (if vent cap is not already assembled).

### CLEANING

#### NOTE

For routine cleaning, it is not necessary to remove cup from gun.

#### CAUTION

**Do not soak the lid in solvent for extended periods of time. Doing so could cause cup/lid sealing problems and leakage.**

The cup lid is designed to be disposable but may be cleaned and reused if slightly contaminated with overspray. **If lid becomes tight, or does not fit, it is due to extended soaking in solvent. Let lid air dry overnight and the lid should return to its original size and fit.**

Remove lid and properly dispose of any excess paint. Pour in a small amount of clean solvent. The amount will vary with different coatings and solvents. Reinstall lid. Shake cup to wash down the inside surfaces. **Hold lid while shaking to prevent lid from coming off.** Pull trigger to allow some solvent to be flushed through gun. Remove lid and pour out dirty solvent. Add a small amount of clean solvent and repeat procedure. Wipe exterior of lid with a clean cloth and clean solvent.

If a paint filter was used in the bottom of the cup outlet, it should be removed and cleaned or replaced at this time. Dispose of used cup lid if contaminated and replace with new.

### CUP DRAWINGS

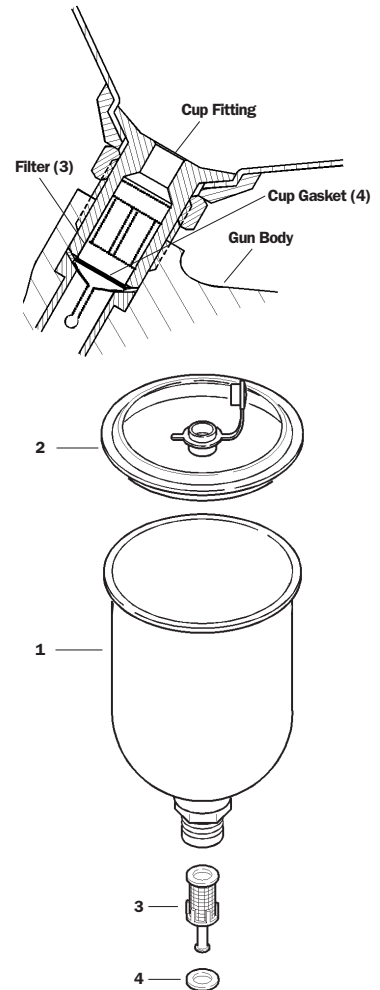

### Parts List

REF NO.	REPLACEMENT PART NO.	DESCRIPTION
1	702576	Metal Gravity Feed Cup (900cc)
2	GFC-404-K2	Disposable Lid Kit (Kit of 2)
3	KGP-5-K5	Filter Kit (Kit of 5)
4	KGP-13-K5	Cup Gasket (Blue) (Kit of 5)