



SXMC38 and SXMC12
3/8" and 1/2" SUPER DUTY MINI
IMPACT WRENCH



⚠ WARNING



ALWAYS READ INSTRUCTIONS BEFORE USING POWER TOOLS



ALWAYS WEAR HEARING PROTECTION



ALWAYS WEAR SAFETY GOGGLES



AVOID PROLONGED EXPOSURE TO VIBRATION

SXMC38 - SPECIFICATIONS

Breakaway Torque.....	450 ft. lbs.
Working Torque	102 ~350 ft. lbs.
Free Speed	7,000 RPM
Air Inlet.....	1/4" NPT
Recommended Hose Size	3/8" I.D.
Avg. Air Cons.....	3.76 CFM
Sound Level.....	98 dbA
Weight.....	2.9 lbs.
Length.....	4.29"
Vibration Level.....	7.5 m/sec ²

SXMC12 - SPECIFICATIONS

Breakaway Torque.....	500 ft. lbs.
Working Torque	102 ~350 ft. lbs.
Free Speed	9,500 RPM
Air Inlet.....	1/4" NPT
Recommended Hose Size	3/8" I.D.
Avg. Air Cons.....	3.76 CFM
Sound Level.....	98 dbA
Weight.....	2.9 lbs.
Length.....	4.29"
Vibration Level.....	7.5 m/sec ²

⚠ WARNING

FAILURE TO OBSERVE THESE WARNINGS COULD RESULT IN INJURY

THIS INSTRUCTION MANUAL CONTAINS IMPORTANT SAFETY INFORMATION.

READ THIS INSTRUCTION MANUAL CAREFULLY AND UNDERSTAND ALL INFORMATION BEFORE OPERATING THIS TOOL.



• Read and understand all instructions. Failure to follow all instructions listed below, may result in electric shock, fire, explosion and/or serious personal injury. It is the responsibility of the owner to make sure all personnel read this manual prior to using the device. It is also the responsibility of the device owner to keep this manual intact and in a convenient location for all to see and read. If the manual or product labels are lost or not legible, contact Sunex Tools for replacements. If the operator is not fluent in English, the product and safety instructions shall be read and discussed with the operator in the operator's native language by the purchaser/owner or his designee, making sure that the operator comprehends its contents.

• Always operate, inspect and maintain this tool in accordance with American National Standards Institute Safety Code of Portable Air Tools (ANSI B186.1) and any other applicable safety codes and regulations.



• For safety, top performance and maximum durability of parts, operate this tool at 90 psig; 6.2 bar max air pressure with 3/8" diameter air supply hose.



• Always wear impact-resistant eye protection when operating or performing maintenance on this tool (users and bystanders).



• High sound levels can cause permanent hearing loss. Always use hearing protection as recommended by your employer an OSHA regulations while using this tool (users and bystanders).

• Keep the tool in efficient operating condition.

• Operators and maintenance personnel must be physically able to handle the bulk, weight and power of this tool.



• Air under pressure can cause severe injury. Never direct air at yourself or others. Always turn off the air supply, drain hose of air pressure and detach tool from air supply before installing, removing or adjusting any accessory on this tool, or before performing any maintenance on this tool. Failure to do so could result in injury. Whip hoses can cause serious injury. Always check for damaged, frayed or loose hoses and fittings, and replace immediately. Do not use quick detach couplings at tool. See instructions for correct set-up.



• Keep tool out of reach of children.

• Air powered tools can vibrate in use. Vibration, repetitive motions or uncomfortable positions over extended periods of time may be harmful to your hands and arms. Discontinue use of tool if discomfort, tingling feeling or pain occurs. Seek medical advice before resuming use.



• Slipping, tripping and/or falling while operating air tools can be a major cause of serious injury or death. Be aware of excess hose left on the walking or work surface.



• Place the tool on the work before starting the tool. Do not point or indulge in any horseplay with this tool.



• Keep body working stance balanced and firm. Do not overreach when operating the tool.

• Note direction of rotation BEFORE operating this tool.

• Anticipate and be alert for sudden changes in motion during start up and operation of any power tool.

• Do not carry tool by the hose. Protect the hose from sharp objects and heat.

• Tool shaft may continue to rotate briefly after throttle is released. Avoid direct contact with accessories during and after use. Gloves will reduce the risk of cuts or burns.



• Keep away from rotating end of tool. Do not wear jewelry or loose clothing. Secure long hair. Scalping can occur if hair is not kept away from tool and accessories. Choking can occur if neckwear is not kept away from tool and accessories.

• Do not use (or modify) the tool for any other purpose than that for which it was designed without consulting the manufacturer's authorized representative.

• Impact wrenches are not torque control devices. Fasteners with specific torque requirements must be checked with suitable torque measuring devices after installation with an impact wrench.

• **Use only impact sockets and accessories on this tool. Do not use hand sockets and accessories.**

• Use accessories recommended by Sunex Tools.

• Do not lubricate tools with flammable or volatile liquids such as kerosene, diesel or jet fuel.

• This tool is not insulated against electric shock.

• This tool must not be used in explosive atmospheres.

• Servicing and repairs should only be made by an authorized service center.

• Do not force tool beyond its rated capacity.

• Do not remove any labels. Replace damaged labels.

• This product may contain one or more chemicals known to the State of California to cause cancer and birth defects or other reproductive harm. *Wash hands thoroughly after handling.*

• Failure to heed these warnings may result in serious or fatal personal injury and/or property damage.



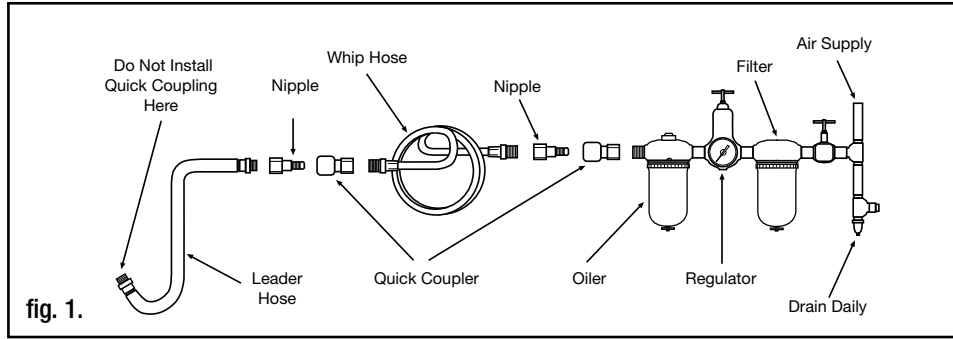

INSTRUCTION MANUAL

This product is designed to tighten or loosen threaded fasteners. No other use is permitted.

AIR SUPPLY REQUIREMENTS

Tools operate on a wide range of air pressures. It is recommended that air pressure measures 90 psig at the tool with the trigger fully depressed and no load applied to the tool. Higher pressure (over 90 psig; 6.2 bar) raises performance beyond the rated capacity of the tool, which will shorten tool life and could cause injury.

Always use clean, dry air. Dust, corrosive fumes and/or water in the air line will cause damage to the tool. Drain the water from air lines and compressor prior to running tool. Clean the air inlet filter screen weekly. The recommended hookup procedure can be viewed in the Figure 1.

The air inlet used for connecting air supply has standard 1/4" NPT. Line pressure should be increased to compensate for unusually long air hoses (over 25 feet). Minimum hose diameter should be 3/8" I.D. and fittings should have the same inside dimensions and be tightly secured.

Always turn off the air supply, drain hose of air pressure and detach tool from air supply before installing, removing or adjusting any part or accessory on this tool, or before performing any maintenance on this tool.

Ensure an accessible emergency shut off valve has been installed in the air supply line and make others aware of its location.

LUBRICATION

Lubricate the air motor daily with high quality air tool oil. If no air line oiler is used, run 1/2 oz. of oil through the tool. The oil can be squirted into the tool air inlet or into the hose at the nearest connection to the air supply, then run the tool. The oil plug is only for adding multi-purpose grease after repair or maintenance of the impact mechanism. Overfilling will cause a reduction in the power of the tool.

WARNING: After an air tool has been lubricated, oil will discharge through the exhaust port during the first few seconds of operation. The exhaust port must be covered with a towel before applying air pressure to prevent serious injury.

OPERATION

Always turn off the air supply, drain hose of air pressure and detach tool from air supply before installing, removing or adjusting any part or accessory on this tool, or before performing any maintenance on this tool.

This impact wrench is rated at 3/8" and 1/2" USS bolt size. Rating must be down graded for spring U bolts, tie bolts, long cap screws, double depth nuts, badly rusted conditions and spring fasteners as they absorb much of the impact power. When possible, clamp or wedge the bolt to prevent springback.

Soak rusted nuts in penetrating oil and break rust seal before removing with impact wrench. If nut does not start to move in three to five seconds, use a larger size impact wrench. Do not use impact wrench beyond rated capacity as this will drastically reduce tool life.

The reversing lever is used to change the direction of the tool. When the valve is pushed to the left, the tool is in a forward or right hand direction. When the valve is pushed to the right, the direction is reverse or left hand.

NOTE: Actual torque on a fastener is directly related to joint hardness, tool speed, condition of socket and the time the tool is allowed to impact. Use the simplest possible tool-to-socket hook up. Every connection absorbs energy and reduces power.

WARNING: Use only impact sockets and accessories on this tool. Do not use hand sockets and accessories.

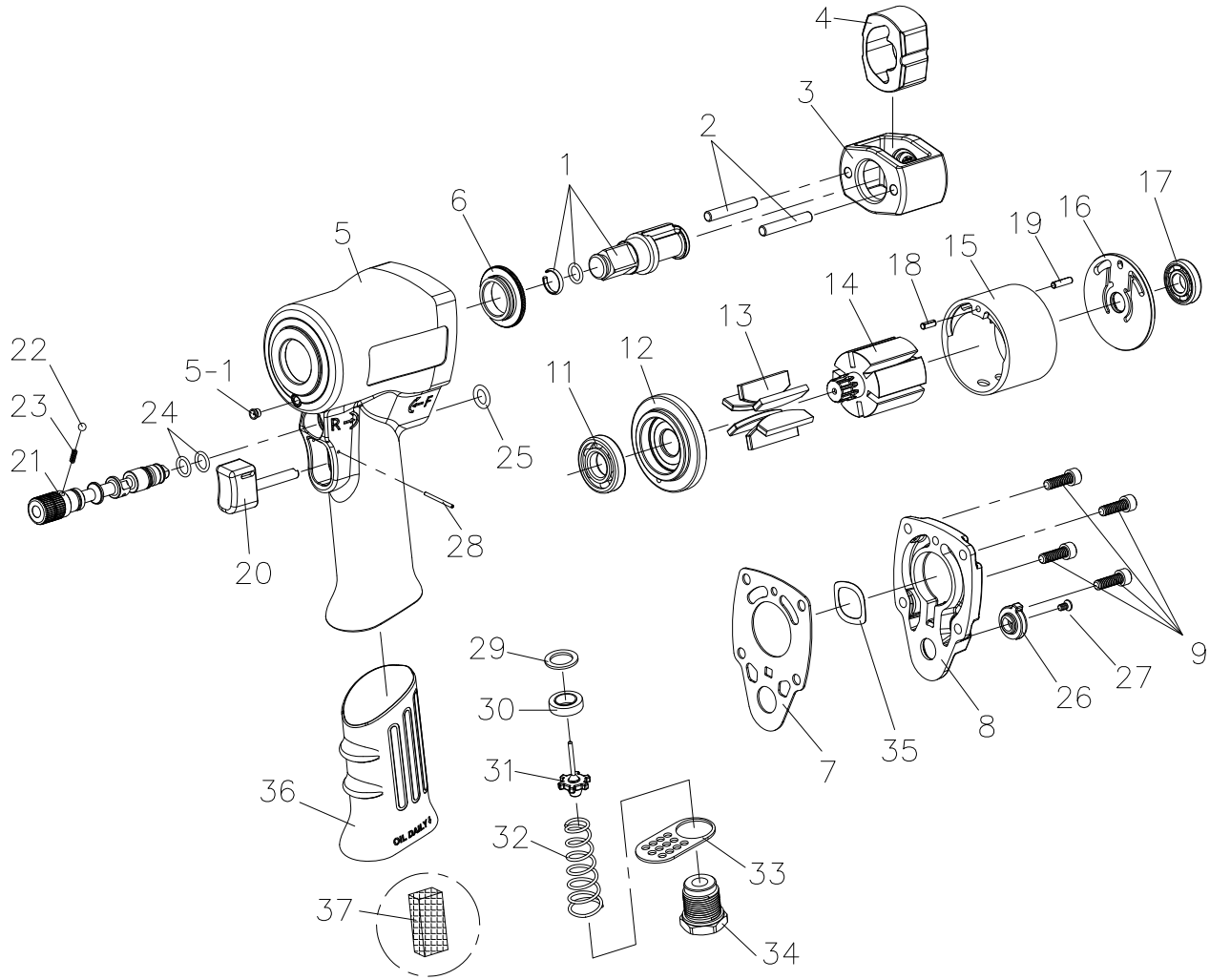

ITEM NO.	PART NO.	DESCRIPTION	QTY.
1	RS383821	3/8" Dr. Anvil Assembly (Incl. O-Ring & Socket Retainer)	1
	RS381221	1/2" Dr. Anvil Assembly (Incl. O-Ring & Socket Retainer)	1
2	RS381222	Hammer Pin	2
3	RS381223	Hammer Cage	1
4	RS381224	Hammer	1
5	RS381207	Motor Housing (Incl. #5-1)	1
5-1		Grease Fitting (Incl. with #5)	1
6	RS381218	Anvil Bushing	1
7	RS381234	Gasket	1
8	RS381236	Housing Cap	1
9	RS381239	Hex SOC. HD Bolts	4
11	RS85324	Ball Bearing	1
12	RS381226	Front Plate	1
13	RS381228	Rotor Blade	6
14	RS381227	Rotor	1
15	RS381229	Cylinder	1
16	RS381232	Rear Plate	1
17	RS381233	Ball Bearing	1
18	RS381230	Spring Pin	1
19	RS381231	Spring Pin	1

ITEM NO.	PART NO.	DESCRIPTION	QTY.
20	RS381208	Trigger	1
21	RS381212	Reverse Valve	1
22	RS381210	Steel Ball	1
23	RS381211	Spring	1
24	RS381213	O-Ring	2
25	RS381214	O-Ring	1
26	RS381237	Power Management Knob	1
27	RS381238	Screw	1
28	RS381216	Spring Pin	1
29	RS381206	Seal Bushing	1
30	RS381205	Seal	1
31	RS381204	Valve Stem	1
32	RS381203	Throttle Valve Spring	1
33	RS381202	Exhaust Deflector	1
34	RS381201	Air Inlet	1
35	RS381235	Washer	1
36	RS381240	Grip	1
37	RS383841	SXMC38 - Muffler	1
Not Shown	RSSXMC38PLK	SXMC38PLK Product Label Kit	1
	RSSXMC12PLK	SXMC12PLK Product Label Kit	1