

SUNEX^{HD}

SX6210

Quiet has a new name

REVERSIBLE CUT-OFF TOOL

Product Safety Information



Save these instructions

CE

⚠ WARNING	
	Read this manual before operating tool.
	Always wear eye protection when operating or performing maintenance on this tool.
	Always wear hearing protection when operating this tool.



⚠ WARNING

To reduce the risk of injury, anyone using, repairing, maintaining, or changing accessories on this tool must read and understand these instructions before performing any of these tasks.

- ⚠ Always inspect, operate, and maintain this tool in accordance with American National Standards Institute Safety Code of Portable Air Tools (ANSI B186.1) and any other applicable safety codes and regulations.
- ⚠ These tools are rated at 90 psi / 6.2 bar max air pressure for safety, top performance, and maximum durability of parts; do not exceed this pressure while the tool is running.
- ⚠ Always shut off air supply, drain hose of air pressure and disconnect tool from air supply when not in use, before changing accessories, or when making repairs.
- ⚠ Never direct air at yourself or anyone else.
- ⚠ Always wear impact-resistant eye and face protection when operating or performing maintenance on this tool.
- ⚠ High sound levels can cause permanent hearing loss. Always use hearing protection when using this tool as recommended by your employer or OSHA regulation.
- ⚠ Do not wear jewelry or loose fitting clothes.
- ⚠ Do not use quick disconnect couplings at tool. See operating instructions for proper set up.
- ⚠ Whipping hoses can cause serious injury. Always carefully check for damaged or loose hoses and fittings before operating this tool.
- ⚠ Never tamper with or remove cutting wheel guard.
- ⚠ Avoid direct contact with accessories during and after use. Gloves should be worn to reduce the risk of cuts or burns.
- ⚠ Never run the tool off of the work. The tool may run too fast and cause the accessory to be thrown off of the tool.
- ⚠ Slipping, tripping, and/or falling while operating air tools can be a major cause of serious injury or death. Be aware of your surroundings and any excess hose left on the walking or working surface.
- ⚠ Pneumatic tools can cause vibration in use. Vibration, repetitive motions or uncomfortable positions over extended periods of time may be harmful to your hands and arms. Discontinue use of tool if discomfort, tingling feeling or pain occurs. Consult a physician before resuming use if any of these symptoms occur.
- ⚠ Do not stretch or overreach while using this tool.
- ⚠ If tool appears to malfunction, remove from service immediately and arrange for repair.
- ⚠ Never use tool if there is any chance of coming into contact with line electricity.
- ⚠ Use only Sunex certified spare parts for any repair made to tool. Repairs should only be performed by properly trained persons.

- ⚠ Do not lock, tape or wire the tool valve in the "on/off" position.
- ⚠ Do not allow the exhaust air to come in contact with hot surfaces or flames.
- ⚠ Avoid inhaling dust or handling debris from the work process, which can be harmful to your health. Use dust extraction and wear respiratory protective equipment when working with materials which produce airborne particles.
- ⚠ Some dust created by power sanding, sawing, grinding, drilling and other construction activities contains chemicals known to the State of California to cause cancer and birth defects or other reproductive harm. Some examples of these chemicals are:
 - Lead from lead based paints
 - Crystalline silica bricks and cement and other masonry products
 - Arsenic and chromium from chemically-treated lumber

Your risk from these exposures varies, depending on how often you do this type of work. To reduce your exposure to these chemicals: work in a well ventilated area, and work with approved safety equipment, such as those dust masks that are specially designed to filter out microscopic particles.

Additional Safety Warnings

- ⚠ Do not modify this tool or its accessories.
- ⚠ Daily measure the air tool speed with tachometer to make sure it is not greater than the RPM stated on the cutting wheel accessory.
- ⚠ This tool is not recommended for use in explosive atmospheres or underwater use.
- ⚠ Operators and maintenance personnel must be physically able to handle the bulk, weight, and power of this tool.
- ⚠ This tool is for professional use only.

SAFETY INSTRUCTIONS - DO NOT DISCARD - GIVE TO USER

Instruction Manual

This tool is designed for cutting plastics, fiberglass, composites and metals. No other use is permitted.

Air Supply Requirements

Tool is designed to operate at 90 psi (6.2 bar) at free speed measured at the tool, of clean, dry air. Operating this tool at higher pressures will drastically reduce the tool life and could cause injury.

The air inlet thread on this tool is a standard 1/4" NPT. Line pressure should be increased for any unusually long air hose run (over 25 feet). Minimum hose diameter should be 3/8" I.D. and all fittings should have the same inside diameter. See diagram below for proper air supply setup.

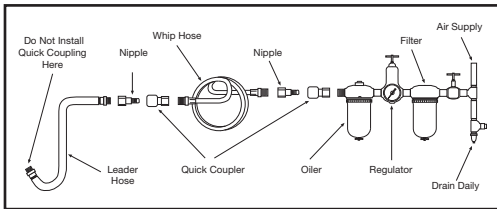

Lubrication

Lubricate the tool each day after use with quality SAE #10 air motor oil. Add the oil to the air inlet or into the hose at the nearest connection to the air supply, then run the tool until all excess oil is expelled from the exhaust. Total oil quantity needed for this procedure is approximately 1 ounce.

EC DECLARATION OF CONFORMITY

We, Sunex International Inc., declare under our sole responsibility that the product to which this declaration relates, is in conformity with the requirements of the Council Directive of June 1998 on the approximation of the laws of the Member States relating to machinery. (EN792, 98/37/EC)

Harmonized Standards Applied:
EN 792-6

National Standards Applied:
ISO 8662-7, ISO 15744-2002

Machine Name:
SX6210 Reversible Cut-Off Tool

Serial No.:
TS010380000 or higher

Technical Data:
3" Cutting Wheel Std.
Air Pressure: 90 psi (6.2 bar)

Noise and Vibration Declaration

Tool produces a noise level (no load) of 87 dBA sound pressure with 3 dBA uncertainty per EN ISO15744-2002. Vibration level is 0.7 m/s² tested per EN 28662-1 & EN28662-7:1997

Signature of Issuer:

Name and Position of Issuer: John Stratton, Product Manager
Sunex International Inc.

Date of Issue: October 15, 2010

Specifications	
Wheel Size.....	3"
Free Speed	18,000 RPM
Motor Size	0.9 HP
Length.....	8.3" (211mm)
Weight.....	2 Lbs. (0.91 kg)
Avg. Air. Cons.....	3.6 cfm (102 l/min)
Air Inlet.....	1/4" NPT
Min. Hose Size.....	3/8" I.D. (10mm)

SUNEX HD

SX6210

REVERSIBLE CUT-OFF TOOL

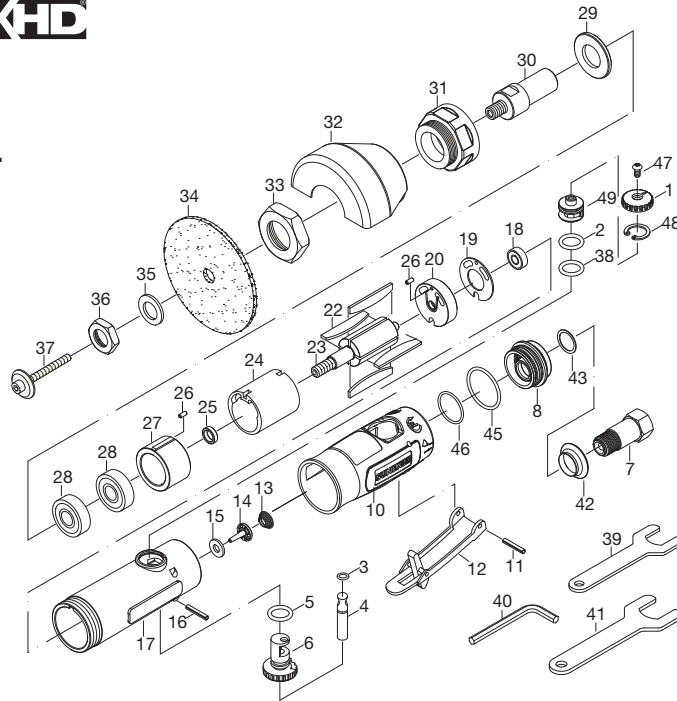

REF. NO.	PART NO.	DESCRIPTION	QTY.
1	RS621001	Regulator	1
2	RS820R02	O-Ring (AS015)	1
3	RS246002	O-Ring (3.5 x 1.4)	1
4	RS621004	Valve Stem	1
5	RS288302	O-Ring (P10)	1
6	RS621006	Regulator	1
7	RS850XLR07	Air Inlet	1
8	RS621008	Muffler	1
10	RS621010	Protecting Rubber	1
11	RS621011	Pin (3 x 24L)	1
12	RS820R12	Lever	1
13	RS820R13	Spring	1
14	RS820R14	Valve	1
15	RS820R15	Washer (6 x 13.8 x 1.6T)	1
16	RS820R161A	Pin (2.8 x 25.8L)	1
17	RS621017	Housing	1
18	RS21114	Bearing (626ZZ)	1
19	RS820R19	Washer (17 x 33.2 x 0.8T)	1
20	RS820R20	Rear Plate	1
22	RS820R22	Rotor Blade	4
23	RS820R23	Rotor	1
24	RS621024	Cylinder	1
25	RS820R25	Bearing Spacer	1
26	RS288323	Pin (2.5 x 6L)	2

REF. NO.	PART NO.	DESCRIPTION	QTY.
27	RS820R27	Front Plate	1
28	RS10920	Bearing (6000ZZ)	2
29	RS820R29	Washer (22 x 33.2 x 3T)	1
30	RS820R30	Disc Retainer	1
31	RS820R31	Clamp Nut	1
32	RS621032	Guard	1
33	RS621033	Nut	1
34	*	3" Disc Wheel	1
35	RS820R35	Washer (9.6 x 21 x 1.5T)	1
36	RS820R36	Nut	1
37	RS820R37	Screw	1
38	RS850XLR60	O-Ring (S16)	1
39	RS20639	Stop Spanner 19 mm	1
40	RS31539	Hex	1
41	RS103841	Stop Spanner	1
42	RS103740	Muffler Body	1
43	RS850XLR71	Washer	1
45	RS850XLR72	O-Ring (AS125)	1
46	RS850XLR73	O-Ring (S30)	1
47	RS850XLR77	Screw (M4 x 8)	1
48	RS850XLR78	Snap Ring (RTW-18)	1
49	RS850XLR79	Regulator	1

* Replacement Disc wheels available as: 87602 (Pack of 5).