



SX232B
1/4" DRIVE ANGLE
DIE GRINDER



SPECIFICATIONS

Max. Free Speed	20,000 RPM
Collet Size.....	1/4"
Average Air Consumption.....	4 CFM
Air Inlet.....	1/4" NPT
Air Supply Hose Size.....	3/8" I.D.
Length	6.38"
Weight.....	1 LB
Sound Level.....	93.6 dBA

! WARNING

Some dust created by power sanding, sawing, grinding, drilling, and other construction activities contains chemicals known to cause cancer, birth defects or other reproductive harm. Some examples of these chemicals are:

- lead from lead-based paints,
- crystalline silica from bricks and cement and other masonry products, and
- arsenic and chromium from chemically-treated lumber.

Your risk from these exposures varies, depending on how often you do this type of work. To reduce your exposure to these chemicals: work in a well ventilated area, and work with approved safety equipment, such as those dust masks that are specially designed to filter out microscopic particles.

! WARNING



RATED RPM OF ACCESSORY USED MUST EXCEED THE MAXIMUM TOOL RPM SHOWN



READ THIS MANUAL BEFORE OPERATING TOOL



ALWAYS WEAR EYE PROTECTION WHEN OPERATING OR PERFORMING MAINTENANCE ON THIS TOOL



ALWAYS WEAR HEARING PROTECTION WHEN OPERATING THIS TOOL



AVOID PROLONGED EXPOSURE TO VIBRATION

! WARNING

FAILURE TO OBSERVE THESE WARNINGS COULD RESULT IN INJURY

THIS INSTRUCTION MANUAL CONTAINS IMPORTANT SAFETY INFORMATION.

READ THIS INSTRUCTION MANUAL CAREFULLY AND UNDERSTAND ALL INFORMATION BEFORE OPERATING THIS TOOL.



- Read and understand all instructions. Failure to follow all instructions listed below, may result in electric shock, fire, explosion and/or serious personal injury. It is the responsibility of the owner to make sure all personnel read this manual prior to using the device. It is also the responsibility of the device owner to keep this manual intact and in a convenient location for all to see and read. If the manual or product labels are lost or not legible, contact Sunex Tools for replacements. If the operator is not fluent in English, the product and safety instructions shall be read and discussed with the operator in the operator's native language by the purchaser/owner or his designee, making sure that the operator comprehends its contents.

- Always operate, inspect and maintain this tool in accordance with American National Standards Institute Safety Code of Portable Air Tools (ANSI B186.1) and any other applicable safety codes and regulations.

- For safety, top performance and maximum durability of parts, operate this tool at 90 psig; 6.2 bar max air pressure with 3/8" diameter air supply hose.

- Always wear impact-resistant eye and face protection when operating or performing maintenance on this tool (users and bystanders).

- High sound levels can cause permanent hearing loss. Always use hearing protection as recommended by your employer an OSHA regulations while using this tool (users and bystanders).

- Keep the tool in efficient operating condition.

- Operators and maintenance personnel must be physically able to handle the bulk, weight and power of this tool.

- Air under pressure can cause severe injury. Never direct air at yourself or others. Always turn off the air supply, drain hose of air pressure and detach tool from air supply before installing, removing or adjusting any accessory on this tool, or before performing any maintenance on this tool. Failure to do so could result in injury. Whip hoses can cause serious injury. Always check for damaged, frayed or loose hoses and fittings, and replace immediately. Do not use quick detach couplings at tool. See instructions for correct set-up.

- Keep tool out of reach of children.

- Air powered tools can vibrate in use. Vibration, repetitive motions or uncomfortable positions over extended periods of time may be harmful to your hands and arms. Discontinue use of tool if discomfort, tingling feeling or pain occurs. Seek medical advice before resuming use.

- Slipping, tripping and/or falling while operating air tools can be a major cause of serious injury or death. Be aware of excess hose left on the walking or work surface.

- Keep body working stance balanced and firm. Do not overreach when operating the tool.

- Note direction of rotation BEFORE operating this tool.



- Anticipate and be alert for sudden changes in motion during start up and operation of any power tool.

- Do not carry tool by the hose. Protect the hose from sharp objects and heat.

- Tool shaft may continue to rotate briefly after throttle is released. Avoid direct contact with accessories during and after use. Gloves will reduce the risk of cuts or burns.

- Keep away from rotating end of tool. Do not wear jewelry or loose clothing. Secure long hair. Scalping can occur if hair is not kept away from tool and accessories. Choking can occur if neckwear is not kept away from tool and accessories.

- Do not use (or modify) the tool for any other purpose than that for which it was designed without consulting the manufacturer's authorized representative.

- Correct bonded abrasive mounted point grinding wheels, rotary files and carbide burrs are necessary to prevent injury from broken accessories. Do not use chipped or cracked bonded abrasive mounted point grinding wheels, rotary files and carbide burrs. Tighten the bonded abrasive mounted point grinding wheels, rotary files and carbide burrs on the collet to prevent spin off when the Die Grinder is turned off.



- **RPM OF THE ACCESSORY MUST EXCEED TOOL RPM. Use accessories rated at 20,000 RPM or higher.**

- **Never mount a grinding wheel, cut-off wheel, router cutter or drill bit on a Die Grinder.**

- **Never use an arbor, mandrel or any other adaptor to convert the Die Grinder for any other application.**

- **Do not lock, tape or wire the "on/off" safety lever in the "on" position, as the lever must be free to return to the "off" position when released.**

- Use accessories recommended by Sunex Tools.

- Do not lubricate tools with flammable or volatile liquids such as kerosene, diesel or jet fuel.

- This tool is not insulated against electric shock.

- This tool must not be used in explosive atmospheres.

- Servicing and repairs should only be made by an authorized service center.

- Do not force tool beyond its rated capacity.

- Do not remove any labels. Replace damaged labels.

- This product may contain one or more chemicals known to the State of California to cause cancer and birth defects or other reproductive harm. *Wash hands thoroughly after handling.*

- Handling the brass parts of this product will expose you to lead, a chemical known to the State of California to cause birth defects and other reproductive harm. *Wash hands after handling.*

- Failure to heed these warnings may result in personal injury and/or property damage.



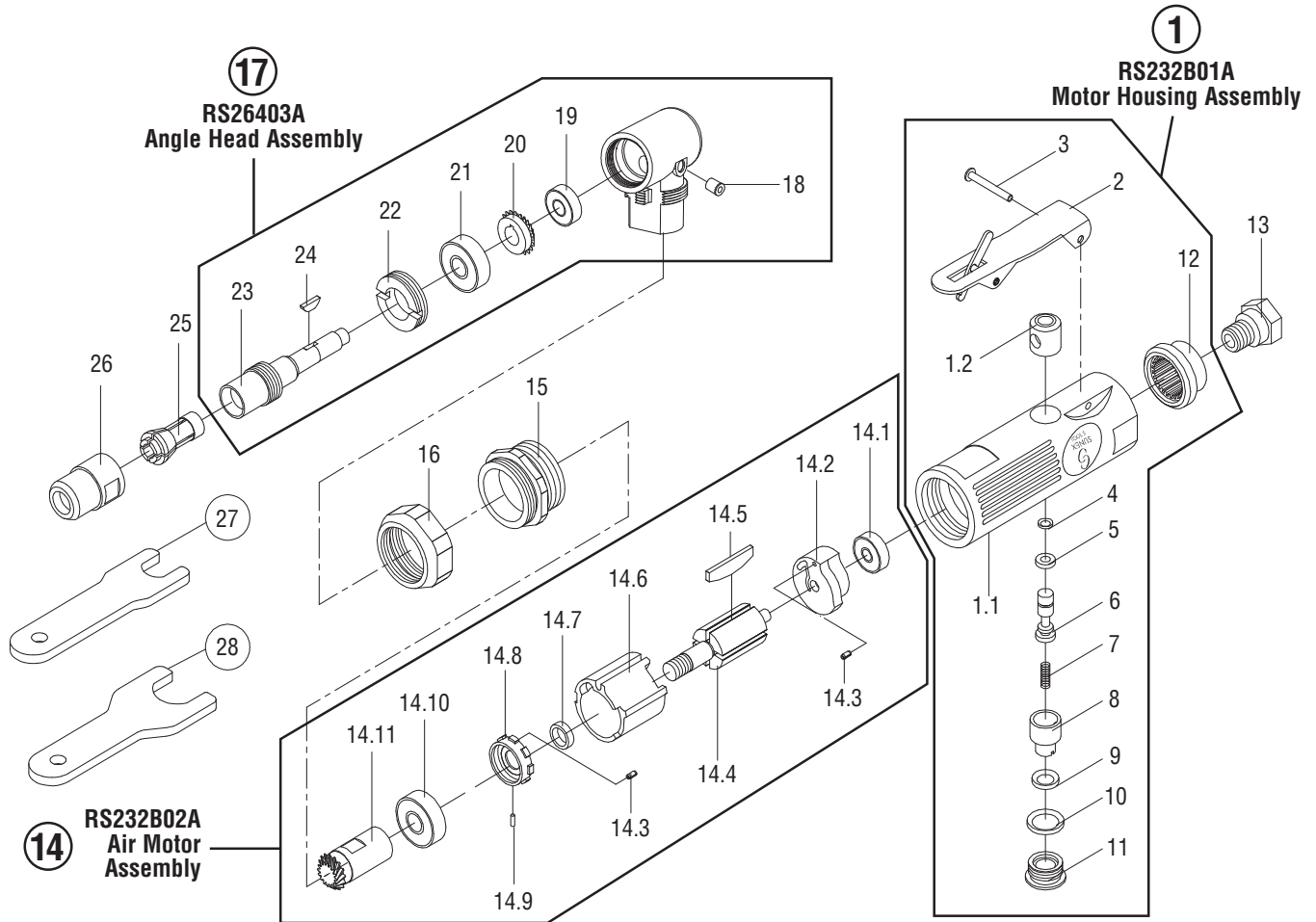

REF. NO.	PART NO.	DESCRIPTION	QTY.
1	RS232B01A	Motor Housing Assembly (incl. #1.1-12)	1
1.1		Housing (incl. with #1)	1
1.2		Valve Bushing (incl. with #1)	1
2		Trigger Assembly (incl. with #1)	1
3		Pin (incl. with #1)	1
4		O-Ring (incl. with #1)	1
5		O-Ring (incl. with #1)	1
6		Valve Stem (incl. with #1)	1
7		Spring (incl. with #1)	1
8		Air Regulator (incl. with #1)	1
9		O-Ring (incl. with #1)	1
10		O-Ring (incl. with #1)	1
11		Valve Plug (incl. with #1)	1
12		Muffle Cover (incl. with #1)	1
13	RS232B18	Air Inlet	1
14	RS232B02A	Cylinder Assembly (incl. #14.1-14.11)	1
14.1		Bearing (incl. with #14)	1
14.2		End Plate (incl. with #14)	1
14.3		Set Pin (incl. with #14)	1
14.4		Rotor (incl. with #14)	1
14.5		Rotor Blade (incl. with #14)	4

REF. NO.	PART NO.	DESCRIPTION	QTY.
14.6		Cylinder (incl. with #14)	1
14.7		Rotor Spacer (incl. with #14)	1
14.8		Front Plate (incl. with #14)	1
14.9		Pin (incl. with #14)	1
14.10		Bearing (incl. with #14)	1
14.11		Gear (incl. with #14)	1
15	RS232B31	Connect Nut	1
16	RS26429	Clamp Nut	1
17	RS26403A	Angle Head Assembly (incl. #18-24)	1
18		Grease Cup (incl. with #17)	1
19		Bearing (incl. with #17)	1
20		Gear (incl. with #17)	1
21		Bearing (incl. with #17)	1
22		Lock Nut (incl. with #17)	1
23		Work Spindle (incl. with #17)	1
24		Key (incl. with #17)	1
25	RS26437	1/4" Collet	1
26	RS26438	Collet Nut	1
27	RS26439	Spanner Wrench	1
28	RS26440	Spanner Wrench	1
29	RSSX232BWL	Warning Label (not shown)	1

Only parts identified by Part No. above are available for purchase.

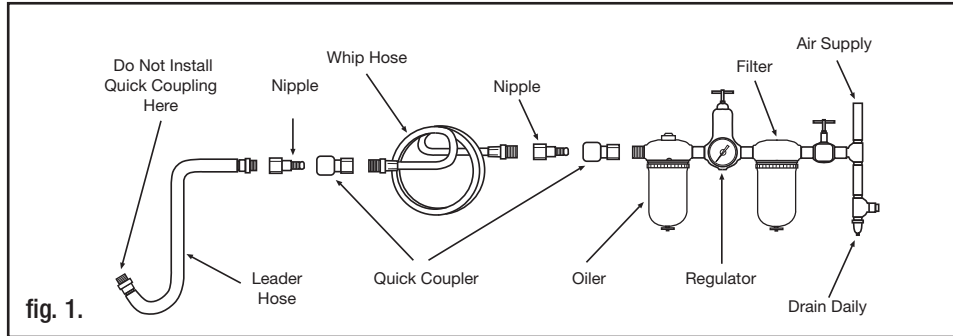

AIR SUPPLY

Tools operate on a wide range of air pressures. It is recommended that air pressure measures 90 psig at the tool with the trigger fully depressed and no load applied to the tool. Higher pressure (over 90 psig; 6.2 bar) raises performance beyond the rated capacity of the tool, which will shorten tool life and could cause injury.

Always use clean, dry air. Dust, corrosive fumes and/or water in the air line will cause damage to the tool. Drain the water from air lines and compressor prior to running tool. Clean the air inlet filter screen weekly. The recommended hookup procedure can be viewed in FIG. 1.

The air inlet used for connecting air supply has standard 1/4" NPT. Line pressure should be increased to compensate for unusually long air hoses (over 25 feet). Minimum hose diameter should be 3/8" I.D. and fittings should have the same inside dimensions and be tightly secured.

Ensure an accessible emergency shut off valve has been installed in the air supply line and make others aware of its location.

TROUBLESHOOTING

Other factors outside the tool may cause loss of power or erratic action. Reduced compressor output, excessive drain on the air line, moisture or restrictions in air pipes or the use of hose connections of improper size or poor conditions may reduce air supply. Grit or gum deposits in the tool may cut power and may be corrected by cleaning the air strainer and flushing out the tool with gum solvent oil or an equal mixture of SAE #10 and kerosene. If outside conditions are in order, disconnect tool from hose and take tool to your nearest authorized service center.

LUBRICATION AND MAINTENANCE

Lubricate the air motor daily with high quality air tool oil. If no air line oiler is used, run 1/2 oz. of oil through the tool. The oil can be squirted into the tool air inlet or into the hose at the nearest connection to the air supply, then run the tool. A rust inhibitive oil is acceptable for air tools.

WARNING: After an air tool has been lubricated, oil will discharge through the exhaust port during the first few seconds of operation. The exhaust port must be covered with a towel before applying air pressure to prevent serious injury.

OPERATION

Always turn off the air supply, drain hose of air pressure and detach tool from air supply before installing, removing or adjusting any part or accessory on this tool, or before performing any maintenance on this tool.

Bonded abrasive mounted point grinding wheels, rotary files and carbide burrs can be mounted providing their speed rating exceeds the speed of the Die Grinder. The shank size of the mounted accessory must match the collet size fitted in the Die Grinder. Insert the shank of the mounted point as far as possible into the collet and tighten the nut using the supplied wrenches. Minimum shank gripping length must be 10mm.

After mounting a new point, start the Die Grinder under bench and run for a few seconds. If the Die Grinder starts to vibrate when first fitting a mounted point or during operation, immediately remove from service. If Die Grinder is dropped, replace bonded abrasive mounted point grinding wheel, rotary file or carbide burr.

When using the Die Grinder, be careful not to exert excessive force which could be hazardous and cause mounted spindle to bend or break.

NOTE: During operation, safety goggles should always be worn to guard against flying debris (users and bystanders).

WARNING: Never mount a grinding wheel, cut-off wheel, router cutter or drill bit on a Die Grinder. Never use an arbor, mandrel or any other adapter to convert the Die Grinder for any other application.