







# SX1819T

## 1/4" HEAVY DUTY RIVET GUN

### SPECIFICATIONS

Rivet Capacity .....	1/4"
Traction Power.....	3,960 lbf.
Stroke Length .....	3/4"
Air Inlet.....	1/4" NPT
Air Supply Hose Size.....	3/8" I.D.
Working Air Pressure.....	70-100 psig (6.2 bar)
Height.....	12-9/16"
Weight.....	5.6 lb.

### ⚠ WARNING

-  ALWAYS READ THIS MANUAL BEFORE OPERATING TOOL
-  ALWAYS WEAR EYE PROTECTION (USERS AND BYSTANDERS) WHEN OPERATING OR PERFORMING MAINTENANCE ON THIS TOOL
-  ALWAYS WEAR HEARING PROTECTION WHEN OPERATING THIS TOOL (USERS AND BYSTANDERS)
-  ALWAYS WEAR FACE PROTECTION WHEN OPERATING THIS TOOL (USERS AND BYSTANDERS)
-  AVOID PROLONGED EXPOSURE TO VIBRATION

### ⚠ WARNING

Some dust created by power sanding, sawing, grinding, drilling, and other construction activities contains chemicals known to cause cancer, birth defects or other reproductive harm. Some examples of these chemicals are:

- lead from lead-based paints,
- crystalline silica from bricks and cement and other masonry products, and
- arsenic and chromium from chemically-treated lumber.

Your risk from these exposures varies, depending on how often you do this type of work. To reduce your exposure to these chemicals: work in a well ventilated area, and work with approved safety equipment, such as those dust masks that are specially designed to filter out microscopic particles.



# ! WARNING

## FAILURE TO OBSERVE THESE WARNINGS COULD RESULT IN INJURY

THIS INSTRUCTION MANUAL CONTAINS IMPORTANT SAFETY INFORMATION.

READ THIS INSTRUCTION MANUAL CAREFULLY AND UNDERSTAND ALL INFORMATION BEFORE OPERATING THIS TOOL.



- Read and understand all instructions. Failure to follow all instructions listed below, may result in electric shock, fire, explosion and/or serious personal injury. It is the responsibility of the owner to make sure all personnel read this manual prior to using the device. It is also the responsibility of the device owner to keep this manual intact and in a convenient location for all to see and read. If the manual or product labels are lost or not legible, contact Sunex Tools for replacements. If the operator is not fluent in English, the product and safety instructions shall be read and discussed with the operator in the operator's native language by the purchaser/owner or his designee, making sure that the operator comprehends its contents.

- Always operate, inspect and maintain this tool in accordance with American National Standards Institute Safety Code of Portable Air Tools (ANSI B186.1) and any other applicable safety codes and regulations.

- For safety, top performance and maximum durability of parts, operate this tool at 90 psig; 6.2 bar max air pressure with 3/8" diameter air supply hose.

- Always wear impact-resistant eye and face protection when operating or performing maintenance on this tool. (users and bystanders).

- High sound levels can cause permanent hearing loss. Always use hearing protection as recommended by your employer an OSHA regulations while using this tool (users and bystanders).

- Keep the tool in efficient operating condition.

- Operators and maintenance personnel must be physically able to handle the bulk, weight and power of this tool.

- Air under pressure can cause severe injury. Never direct air at yourself or others. Always turn off the air supply, drain hose of air pressure and detach tool from air supply before installing, removing or adjusting any accessory on this tool, or before performing any maintenance on this tool. Failure to do so could result in injury. Whip hoses can cause serious injury. Always check for damaged, frayed or loose hoses and fittings, and replace immediately. Do not use quick detach couplings at tool. See instructions for correct set-up.

- Keep tool out of reach of children.

- Air powered tools can vibrate in use. Vibration, repetitive motions or uncomfortable positions over extended periods of time may be harmful to your hands and arms. Discontinue use of tool if discomfort, tingling feeling or pain occurs. Seek medical advice before resuming use.

- Slipping, tripping and/or falling while operating air tools can be a major cause of serious injury or death. Be aware of excess hose left on the walking or work surface.

- Keep body working stance balanced and firm. Do not overreach when operating the tool.

- Do not point or indulge in any horseplay with this tool.



- Anticipate and be alert for sudden changes in motion during start up and operation of any power tool.

- Do not carry tool by the hose. Protect the hose from sharp objects and heat.

- Avoid direct contact with accessories during and after use. Gloves will reduce the risk of cuts or burns.

- Keep away from end of tool. Do not wear jewelry or loose clothing. Secure long hair. Scalping can occur if hair is not kept away from tool and accessories. Choking can occur if neckwear is not kept away from tool and accessories.

- Do not use (or modify) the tool for any other purpose than that for which it was designed without consulting the manufacturer's authorized representative.

- Do not exceed 100 psig maximum air pressure.

- Always disconnect air supply before proceeding with any assembly or disassembly procedures.

- Keep exhaust port pointed away from face.

- Inspect the hydraulic section prior to use. Do not use if cracked. Contact the distributor for repair or replacement.

- Do not pound on the nosepiece or the end of the head or force the rivet into the hole of the nosepiece as this will damage the tool.

- Make sure all parts are correctly and securely fastened.

- Always follow proper maintenance procedures.

- Keep clear of trigger when inserting rivets.

- Use accessories recommended by Sunex Tools.

- Do not lubricate tools with flammable or volatile liquids such as kerosene, diesel or jet fuel.

- This tool is not insulated against electric shock.

- This tool must not be used in explosive atmospheres.

- Servicing and repairs should only be made by an authorized service center.

- Do not force tool beyond its rated capacity.

- Do not remove any labels. Replace damaged labels.

- This product may contain one or more chemicals known to the State of California to cause cancer and birth defects or other reproductive harm. *Wash hands thoroughly after handling.*

- Handling the brass parts of this product will expose you to lead, a chemical known to the State of California to cause birth defects and other reproductive harm. *Wash hands after handling.*

- Failure to heed these warnings may result in personal injury and/or property damage.



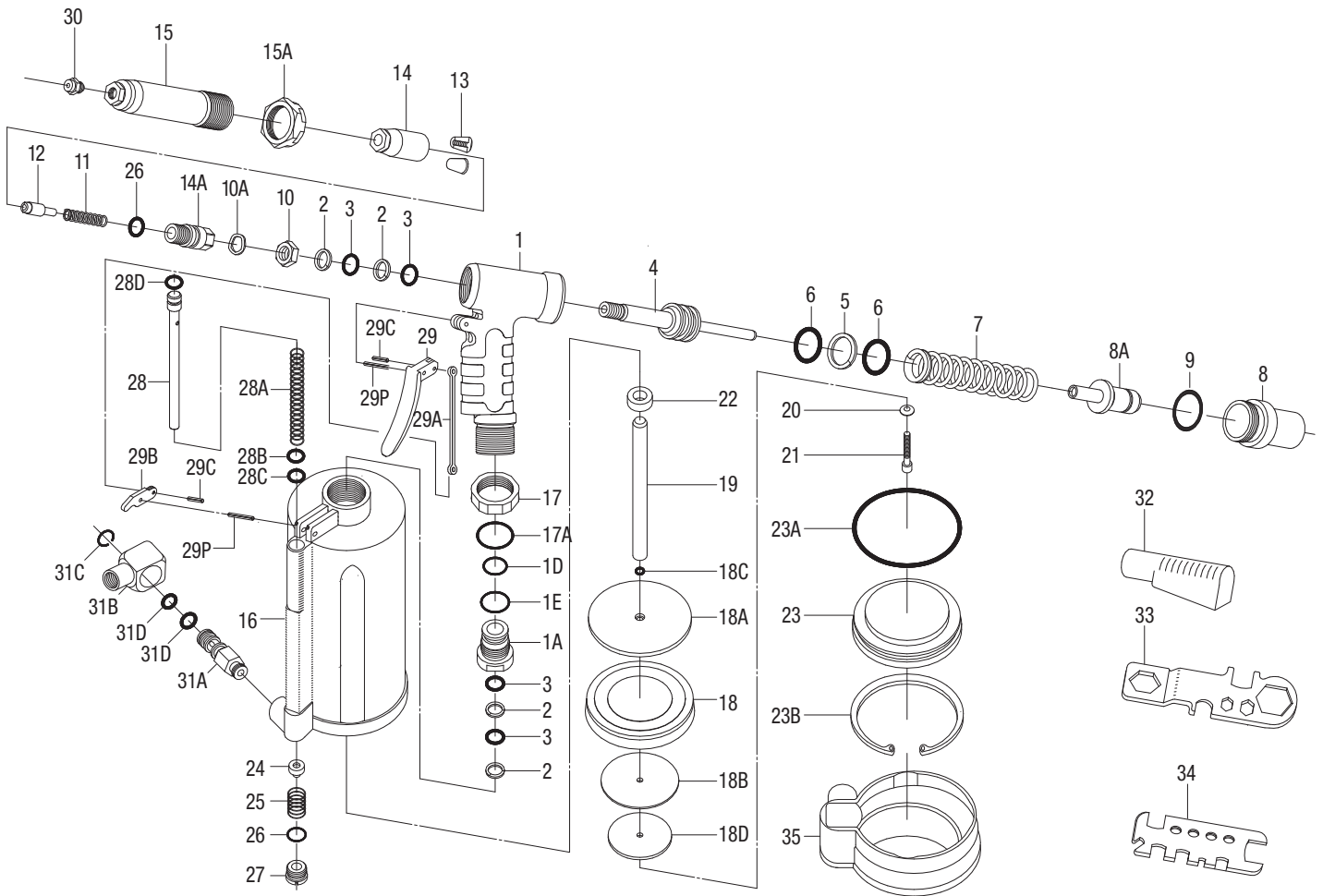

REF. NO.	PART NO.	DESCRIPTION	QTY.
1	RS819101	Hydraulic Section	1
1A	RS819108	Plunger Rod Guide	1
1D	RSOR1823	O-Ring	1
1E	RSOR2227	O-Ring	1
2	RSBR1217	Back-up Ring	4
3	RSOR1217	O-Ring	4
4	RS721301	Hydraulic Plunger	1
5	RSBR2431	Back-up Ring	1
6	RSOR2431	O-Ring	2
7	RS721309	Retainer Spring	1
8	RS721112	Rear Gland	1
8A	RS214103	Guide Tube	1
9	RSOR3034	O-Ring	1
10	RS214306	Nut	1
10A	RSWW1317	Wave Washer	1
11	RS214308	Spring	1
12	RS214302	Jaw Pusher	1
13	RS819303	Jaw "L"	2
14	RS819304	Jaw Housing	1
14A	RS721305	Jaw Housing Coupler	1
15	RS819105	Head	1
15A	RS819106	Lock Nut	1

REF. NO.	PART NO.	DESCRIPTION	QTY.
16	RS721401	Air Cylinder Body	1
17	RS918109	Lock Nut	1
17A	RSOR2832	O-Ring	1
18	RS721502	Packing Ring (incl. w/ #22A)	1
18A	RS721503	Front Head Disc (incl. w/ #22A)	1
18B	RS721504	Rear Head Disc (incl. w/ #22A)	1
18C	RSOR0509	O-Ring (incl. w/ #22A)	1
18D	RS918504	Rear Head Disc (incl. w/ #22A)	1
19	RS819501	Plunger Rod (incl. w/ #22A)	1
20	RSPW0512	Washer (incl. w/ #22A)	1
21	RS508020	Lock Screw (incl. w/ #22A)	1
22	RS612505	Bumper Ring (incl. w/ #22A)	1
22A	RS819500	Piston Assy (incl. #18 - #22)	1
23	RS721402	Air Cylinder Cap	1
23A	RSOR8591	O-Ring	1
23B	RSCH8084	Retaining Ring	1
24	RS918207	Throttle Valve	1
25	RS656204	Throttle Valve Spring	1
26	RSOR1417	O-Ring	2
27	RS612206	Valve Plug	1
28	RS918200	Valve Tube Assy	1
28A	RS918204	Valve Tube Spring	1

REF. NO.	PART NO.	DESCRIPTION	QTY.
28B	RS618605	Brass Collar	1
28C	RSOR0914	O-Ring	1
28D	RSOR0812	O-Ring	1
29	RS612611	Trigger Lever	1
29A	RS918602	Linkage	1
29B	RS721603	Rocker Arm	1
29C	RSSP3006	Roll Pin	2
29P	RSSP3018	Roll Pin	2
30	RS612706	Nose Piece 3/16" (4.8mm)	1
	RS612708	Nose Piece 1/4" (6.4mm)	1
31	RS922100	Swivel Joint Assy (incl. #31A - #31D)	1
31A	RS612715	Male Inlet Body (incl. w/ #31)	1
31B	RS922A01	Female Inlet Body (incl. w/ #31)	1
31C	RSCS1316	Snap Ring (incl. w/ #31)	1
31D	RSOR1015	O-Ring (incl. w/ #31)	2
32	RS612901	Deflector	1
33	RS612904	Multi-Wrench (A)	1
34	RS918905	Multi-Wrench (B)	1
35	RS721403	Rubber Boot	1
	RSSX1819TPLK	Product Label Kit (not shown)	1

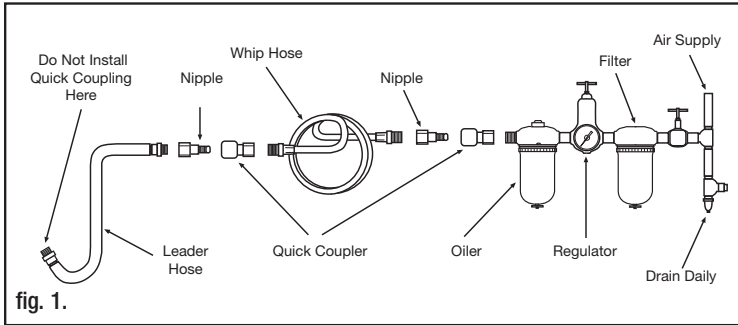

## AIR SUPPLY

Tools operate on a wide range of air pressures. It is recommended that air pressure measures 90 psig at the tool with the trigger fully depressed and no load applied to the tool. Higher pressure (over 90 psig; 6.2 bar) raises performance beyond the rated capacity of the tool, which will shorten tool life and could cause injury.

Always use clean, dry air. Dust, corrosive fumes and/or water in the air line will cause damage to the tool. Drain the water from air lines and compressor prior to running tool. Clean the air inlet filter screen weekly. The recommended hookup procedure can be viewed in FIG. 1.

The air inlet used for connecting air supply has standard 1/4" NPT. Line pressure should be increased to compensate for unusually long air hoses (over 25 feet). Minimum hose diameter should be 3/8" I.D. and fittings should have the same inside dimensions and be tightly secured.

Ensure an accessible emergency shut off valve has been installed in the air supply line and make others aware of its location.

## LUBRICATION AND MAINTENANCE

Lubricate the air motor daily with high quality air tool oil. If no air line oiler is used, run 1/2 oz. of oil through the tool. The oil can be squirted into the tool air inlet or into the hose at the nearest connection to the air supply, then run the tool. A rust inhibitive oil is acceptable for air tools.

**WARNING:** After an air tool has been lubricated, oil will discharge through the exhaust port during the first few seconds of operation. The exhaust port must be covered with a towel before applying air pressure to prevent serious injury.

## OPERATION

Always turn off the air supply, drain hose of air pressure and detach tool from air supply before installing, removing or adjusting any part or accessory on this tool, or before performing any maintenance on this tool.

When the Lever/Trigger is depressed, the throttle valve is moved down off its seat by the valve tube. Air enters the bottom of the air cylinder, forcing the piston assembly up. As the piston assembly rises, the plunger rod forces hydraulic fluid in to the upper part of the hydraulic section, retracting the hydraulic plunger. Meanwhile, the jaws grip the mandrel of the rivet, pulling until the rivet is set and breaking the mandrel in the process.

When the lever is released, the throttle valve resets and shuts off the air supply. The valve tube spring then lifts the valve tube and exhausts the air throughout the hollow of the valve tube. The return spring returns the hydraulic plunger to its original position. This opens the jaws, releases the mandrel, and retracts the piston assembly back to its original static site.

**NOTE:** During operation, safety goggles should always be worn to guard against flying debris (users and bystanders).

## SERVICING PROCEDURES

### 1. Changing Nosepieces:

Hook up the tool to the air line and depress the lever. While continuing to hold the lever down, use the maintenance tool to remove the unwanted nosepiece and tighten the new nosepiece in place again. When the lever is released and the tool is at rest, a circular opening should be visible when looking through the hydraulic section from the rear gland to the nosepiece.

### 2. Cleaning and Changing of the Jaws:

Disconnect the tool from the air line and then remove the head with the maintenance tool. Hold the jaw housing coupler firmly and remove the jaw housing. Clean the jaws with either a steel brush or solvent. If excessive wear is apparent, replace them with new jaws. Before reassembling, apply a thin coat of oil to the sliding surface of the jaws. Reassemble the tool in the reverse order while making sure that the chamfered end of the jaw pusher is in contact with the jaws properly.

### 3. Jaw Opening Adjustment:

To obtain the maximum stroke of the tool, proper distance setting between the jaw housing and the head is very important. First loosen the lock nut. A rivet is then inserted into the nosepiece which should be selected to match the rivet size to be set. While screwing or unscrewing the head to achieve the minimum opening of the jaws, check if the rivet mandrel can be removed and inserted freely. Fasten the lock nut after the adjustment.

## MAINTENANCE

1. Check the tightness of the connections between the jaw housing coupler, nut, jaw housing, and the hydraulic plunger, the nosepiece, the head and the lock nut.
2. If the jaws show excessive wear and/or are dirty, follow the steps provided in the servicing procedures section.

# TROUBLESHOOTING

## **1. Rivet mandrel is gripped by the jaws but the rivet can not be set and mandrel can not be broken:**

**CAUSE:** Low air pressure or loss of hydraulic fluid.

**REMEDY:** Increase air pressure to 7 bar (100 psi) maximum at tool. Make sure all fittings including rear gland and head are tight. If malfunction persists, call authorized Sunex Tools® warranty center.

## **2. Mandrel does not fit completely into nosepiece or fails to eject:**

**CAUSE:** Jaw Housing distance incorrect.

**REMEDY:** Loosen the head and check the rated stroke length. If shorter, search for worn or damaged o-rings and replace it.

**CAUSE:** Jaws are dirty or damaged.

**REMEDY:** Clean or replace the jaws.

**CAUSE:** Fatigued jaw pusher spring.

**REMEDY:** Replace the jaw pusher spring.

**CAUSE:** Fatigued Return Spring.

**REMEDY:** Replace the return spring.

**CAUSE:** Air leakage in vacuum system.

**REMEDY:** Search for worn or damaged seals in the vacuum system and replace it.

## **3. Tool takes more than two strokes under ideal conditions to set rivet and break mandrel:**

**CAUSE:** Low air pressure.

**REMEDY:** Increase air pressure but do NOT exceed 7 bar (100 psig) at tool.

**CAUSE:** Loose Nosepiece or improper size of nosepiece.

**REMEDY:** Tighten nosepiece or use right size.

**CAUSE:** Rivet body too long for the thickness of the joint.

**REMEDY:** The rivet body should be 3-6mm longer than the thickness of joint only.

**If malfunction persists, call an authorized Sunex Tools® warranty center.**