

!WARNING

Some dust created by power sanding, sawing, grinding, drilling, and other construction activities contains chemicals known to cause cancer, birth defects or other reproductive harm. Some examples of these chemicals are:

- lead from lead-based paints,
- crystalline silica from bricks and cement and other masonry products, and
- arsenic and chromium from chemically-treated lumber.

Your risk from these exposures varies, depending on how often you do this type of work. To reduce your exposure to these chemicals: work in a well ventilated area, and work with approved safety equipment, such as those dust masks that are specially designed to filter out microscopic particles.

!WARNING



ALWAYS READ INSTRUCTIONS BEFORE USING POWER TOOLS



ALWAYS WEAR SAFETY GOGGLES



WEAR HEARING PROTECTION



AVOID PROLONGED EXPOSURE TO VIBRATION

SPECIFICATIONS

Max. Free Speed	230 RPM	Air Consumption	3 CFM
Torque	25 ft. lbs.	Sound Level	87 dBA
Air Inlet	1/4 NPT	Length	7 1/4"
Hose Size	3/8" I.D.	Shipping Wt.	1.14 Lbs.
Air Pressure	90 PSI		

SX106B
1/4" MINI
AIR RATCHET

! WARNING

FAILURE TO OBSERVE THESE WARNINGS COULD RESULT IN INJURY



THIS INSTRUCTION MANUAL CONTAINS IMPORTANT SAFETY INFORMATION.

READ THIS INSTRUCTION MANUAL CAREFULLY AND UNDERSTAND ALL INFORMATION BEFORE OPERATING THIS TOOL.

- Always operate, inspect and maintain this tool in accordance with American National Standards Institute Safety Code of Portable Air Tools (ANSI B186.1) and any other applicable safety codes and regulations.

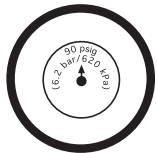

- For safety, top performance and maximum durability of parts, operate this tool at 90 psig 6.2 bar max air pressure with 3/8" diameter air supply hose.



- Always wear impact-resistant eye and face protection when operating or performing maintenance on this tool. Always wear hearing protection when using this tool.



- High sound levels can cause permanent hearing loss. Use hearing protection as recommended by your employer or OSHA regulation.

- Keep the tool in efficient operating condition.

- Operators and maintenance personnel must be physically able to handle the bulk, weight and power of this tool.



- Air under pressure can cause severe injury. Never direct air at yourself or others. Always turn off the air supply, drain hose of air pressure and detach tool from air supply before installing, removing or adjusting any accessory on this tool, or before performing any maintenance on this tool. Failure to do so could result in injury. Whip hoses can cause serious injury. Always check for damaged, frayed or loose hoses and fittings, and replace immediately. Do not use quick detach couplings at tool. See instructions for correct set-up.



- Air powered tools can vibrate in use. Vibration, repetitive motions or uncomfortable positions over extended periods of time may be harmful to your hands and arms. Discontinue use of tool if discomfort, tingling feeling or pain occurs. Seek medical advice before resuming use.



- Air powered tools can vibrate in use. Vibration, repetitive motions or uncomfortable positions over extended periods of time may be harmful to your hands and arms. Discontinue use of tool if discomfort, tingling feeling or pain occurs. Seek medical advice before resuming use.

- Place the tool on the work before starting the tool. Do not point or indulge in any horseplay with this tool.



- Slipping, tripping and/or falling while operating air tools can be a major cause of serious injury or death. Be aware of excess hose left on the walking or work surface.

- Keep body working stance balanced and firm. Do not overreach when operating the tool.

- Anticipate and be alert for sudden changes in motion during start up and operation of any power tool.



- Do not carry tool by the hose. Protect the hose from sharp objects and heat.

- Tool shaft may continue to rotate briefly after throttle is released. Avoid direct contact with accessories during and after use. Gloves will reduce the risk of cuts or burns.

- Keep away from rotating end of tool. Do not wear jewelry or loose clothing. Secure long hair. Scalping can occur if hair is not kept away from tool and accessories. Choking can occur if neckwear is not kept away from tool and accessories.



- Do not lubricate tools with flammable or volatile liquids such as kerosene, diesel or jet fuel.

- Do not force tool beyond its rated capacity.

- Do not remove any labels. Replace any damaged labels.

- Use accessories recommended by Sunex Tools.

SX106B PARTS BREAKDOWN & PARTS LIST

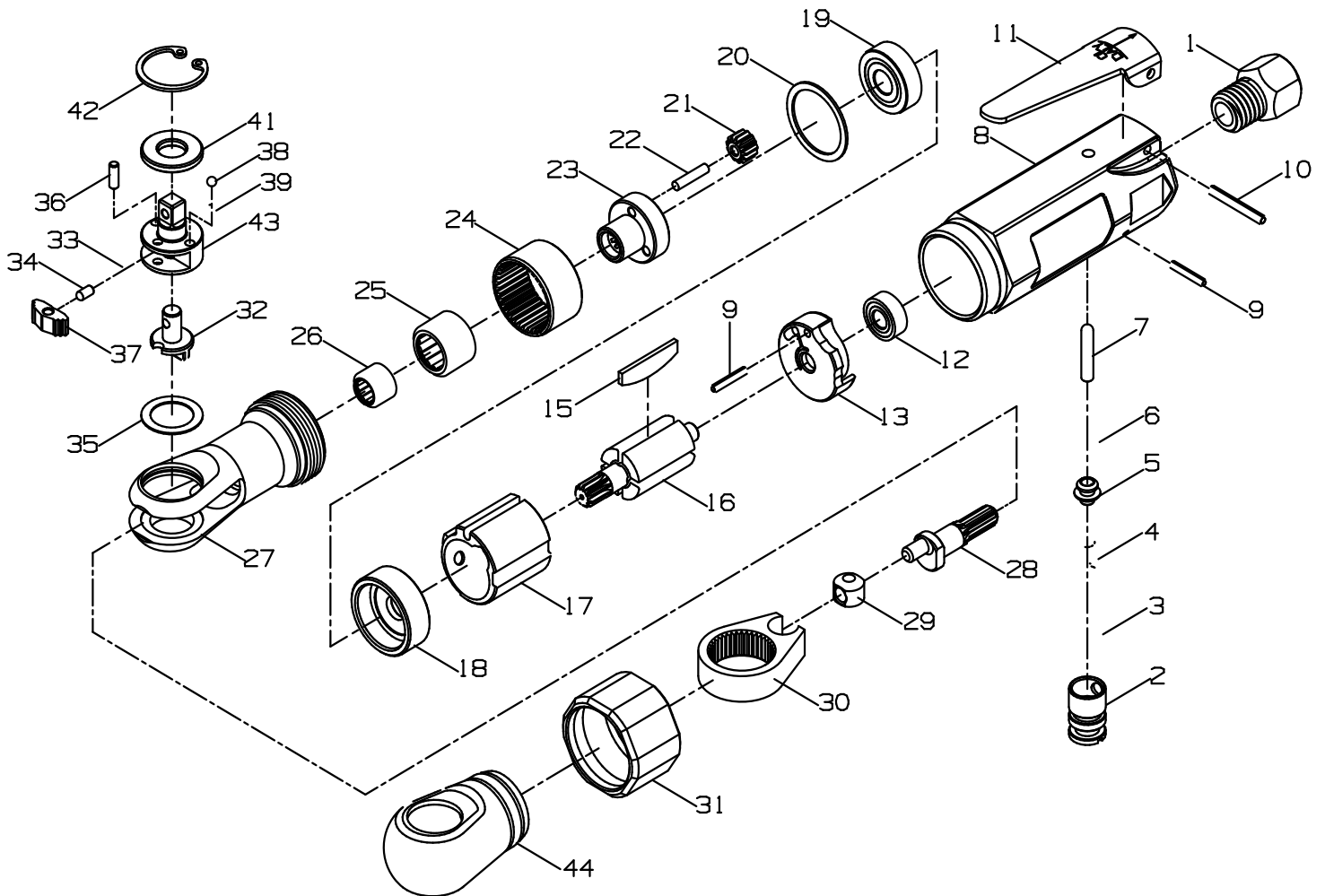

Ref. #	Item #	DESCRIPTION	QTY	Ref. #	Item#	DESCRIPTION	QTY
1	RS106A01	Air Inlet Bushing	1	23	RS106A23	Gear Carrier	1
2	RS106A02	Regulator	1	24	RS106A24	Internal Gear	1
3	RS106A03	O-Ring	1	25	RS106A25	Needle Bearing	1
4	RS106A04	Spring	1	26	RS106A26	Needle Bearing	1
5	RS106A05	Valve Bushing	1	27	RS106A27	Ratchet Housing	1
6	RS106A06	O-Ring	1	28	RS106A28	Crank Shaft	1
7	RS106A07	Valve	1	29	RS106A29	Drive Bushing	1
8	RS106A08	Handle	1	30	RS106A30	Yoke	1
9	RS106A09	Pin	2	31	RS106A31	Hex Lock Nut	1
10	RS106A10	Pin	1	*32		Reverse Button	1
11	RS106A11	Lever	1	*33		Spring	1
12	RS30516	Ball Bearing	1	*34		Lock Pin	1
13	RS106A13	Rear End Plate	1	*35		Washer	1
15	RS106A15	Rotor Blade	4	*36		Pin	1
16	RS106A16	Rotor	1	*37		Ratchet Pawl	1
17	RS106A17	Cylinder	1	*38		Steel Ball	2
18	RS106A18	Front End Plate	1	*39		Spring	2
19	RS21417	Ball Bearing	1	*41		Thrust Washer	1
20	RS106A20	Washer	1	*42		Retaining Ring	1
21	RS106A21	Gear	3	*43		Ratchet Anvil	1
22	RS106A22	Gear Pin	3	44	RS106A44	Rubber Boot	1

* Available only in RSRHK106B Ratchet Head Kit

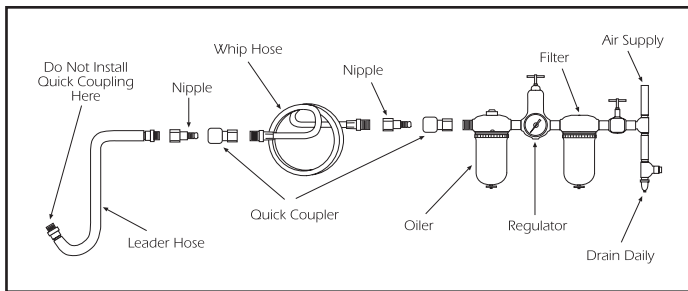

Air Supply

Tools of this class operate on a wide range of air pressures. It is recommended that air pressure of these tools measures 90 PSI at the tool while running free. Higher pressure (over 90 psig; 6.2 bar) raises performance beyond the rated capacity of the tool which will shorten tool life because of faster wear and could cause injury.

Always use clean, dry air. Dust, corrosive fumes and/or water in the air line will cause damage to the tool. Drain the air tank daily. Clean the air inlet filter screen on at least a weekly schedule. The recommended hookup procedure can be viewed in the above figure.

The air inlet used for connecting air supply, has standard 1/4" NPT. Line pressure should be increased to compensate for unusually long air hoses (over 25 feet). Minimum hose diameter should be 3/8" I.D. and fittings should have the same inside dimensions and be tightly secured.

Lubrication

Lubricate the air motor daily with air tool oil. If no air line oiler is used, run 1/2 oz. of oil through the tool. The oil can be squirted into the tool air inlet or into the hose at the nearest connection to the air supply, then run the tool. Overfilling will cause a reduction in the power of the tool.

Operation

This ratchet wrench is rated at 1/4" USS bolt size. Rating must be down graded for spring U bolts, tie bolts, long cap screws, double depth nuts, badly rusted conditions and spring fasteners, as they absorb much of the impact power. When possible, clamp or wedge the bolt to prevent springback.

NOTE: Actual torque on a fastener is directly related to joint hardness, tool speed, condition of socket and the time the tool is allowed to impact.

Use the simplest possible tool-to-socket hook up. Every connection absorbs energy and reduces power.

NOTE: Soak rusted nuts in penetrating oil and break rust seal before removing with ratchet wrench. If nut does not start to move in three to five seconds, use a larger size ratchet wrench. Do not use ratchet wrench beyond rated capacity as this will drastically reduce tool life.

