

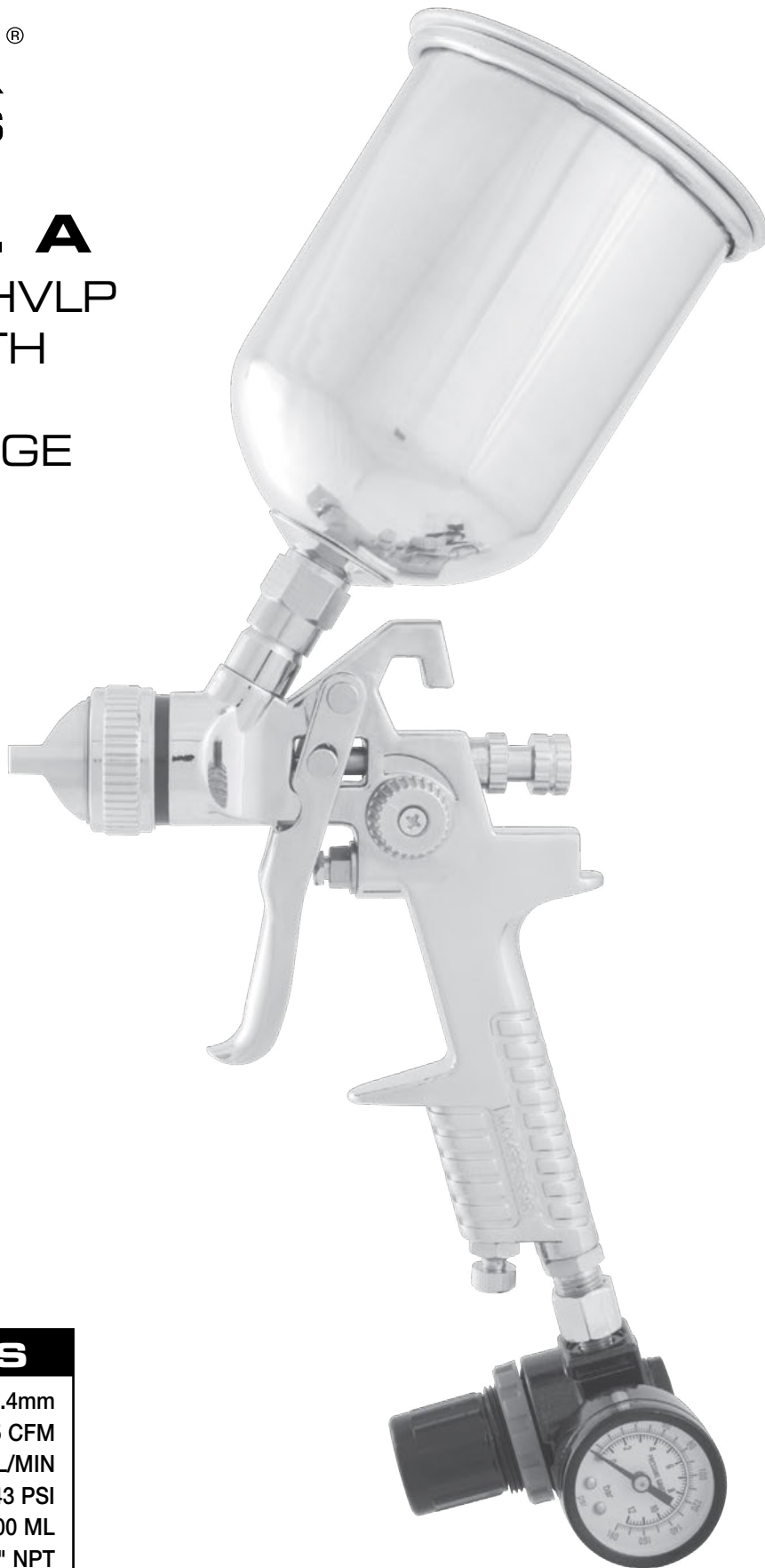

9002B Rev. A

GRAVITY FEED HVLP
SPRAY GUN WITH
REGULATOR /
PRESSURE GAUGE



⚠️ WARNING



ALWAYS READ AND KEEP INSTRUCTIONS BEFORE USING THIS EQUIPMENT



SPRAY GUNS CREATE FLYING PARTICLES. ALWAYS WEAR SAFETY GOGGLES AND BREATHING APPARATUS (USERS AND BYSTANDERS). FLYING PARTICLES CAN CAUSE INJURY



SPECIFICATIONS

Fluid Nozzle	1.4mm
Air Consumption.....	14.5 CFM
Fluid (Water) Delivery	160-220 ML/MIN
Air Pressure	43 PSI
Cup Size.....	600 ML
Air Inlet.....	1/4" NPT



⚠ WARNING

To reduce the risk of injury, anyone using, repairing, maintaining, or changing accessories on this tool must read and understand these instructions before performing any of these tasks.

- ⚠ Read THIS INSTRUCTION MANUAL Carefully and understand ALL INFORMATION Before Operating THIS Tool. KEEP FOR FUTURE USE.
- ⚠ Always operate, inspect and maintain this spray gun in accordance with American National Standards Institute Safety Code of Portable Air Tools (ANSI B186.1) and any other applicable safety codes and regulations.
- ⚠ During use and while cleaning and flushing spray gun solvents can be expelled. Some solvents can cause eye injury. Always wear eye protection.
- ⚠ Be sure all in the area are wearing impact-resistant eye and face protection.
- ⚠ Even small projectiles can injure eyes and cause blindness.
- ⚠ High sound levels can cause permanent hearing loss. Protect yourself from noise. Noise levels vary with work surface. Wear ear protection.
- ⚠ Repetitive work motions, awkward positions and exposure to vibration can be harmful to hands and arms.
- ⚠ Air under pressure can cause severe injury. Always shut off air supply, drain hose of air pressure and disconnect tool from air supply when not in use, before changing accessories or when making repairs. Never direct air at yourself or anyone else. Whipping hoses can cause serious injury. Always check for damaged or loose hoses and fittings. Never use quick change couplings at tool. They add weight and could fail due to vibration. Instead, add a whip hose and connect coupling between air supply and whip hose, or between whip hose and leader hose. Do not exceed maximum air inlet pressure of 43 PSI.
- ⚠ Always use spray gun at a safe distance from other people in work area.
- ⚠ Maintain spray gun with care. Keep tools clean and oiled for best and safest performance. Follow instructions for lubricating and changing accessories. Wiping or cleaning rags and other flammable waste materials must be placed in a tightly closed metal container and disposed of later in the proper fashion.
- ⚠ Do not wear loose or ill-fitting clothing; remove watches and rings.
- ⚠ Do not over reach. Keep proper footing and balance at all times. Slipping, tripping and falling can be a major cause of serious injury or death. Be aware of excess hose left on the walking or work surface.
- ⚠ Do not abuse hoses or connectors. Never carry spray gun by the hose or yank hose to disconnect from air supply. Keep hoses from heat, oil and sharp edges. Check hoses for weak or worn condition before each use, making certain that all connections are secure.
- ⚠ When possible, secure work with clamps or vise so both hands are free to operate tool.
- ⚠ Solvent and paint coatings can be highly flammable when sprayed. Adequate ventilation exhaust must be provided to keep air free of accumulations of flammable materials. Smoking must never be allowed in the spray area. Fire extinguishing equipment must be present in the paint spray area.
- ⚠ Certain painting solvent materials may be harmful if inhaled, or if there is contact with the skin. Always follow the requirements of the Material Safety Data Sheet supplied by your coating material manufacturer. Adequate exhaust ventilation must be provided to keep the air free of accumulations of toxic materials. Always use a mask or respirator whenever there is a chance of inhaling sprayed materials. The mask must be compatible with the material being sprayed and its concentration. Respirator equipment must be NIOSH approved.
- ⚠ Halogenated hydrocarbon solvents - for example: methylene chloride and 1,1,1-Trichlorethene are not chemically compatible with the aluminum that might be used in spray gun components. The chemical reaction caused by these solvents reacting with aluminum can become violent and lead to an equipment explosion. Guns with stainless steel internal passageways may be used with these solvents. However, aluminum is widely used in other spray application equipment. Check all equipment items before use and make sure they can also be used safely with these solvents. Read the label or data sheet for the material you intend to spray. If in doubt as to whether or not a coating or cleaning material is compatible, contact your material supplier.
- ⚠ Spray gun operators should be given adequate training in the safe use and maintenance of the equipment. Users must comply with all local and national codes of practice and insurance company requirements governing ventilation, fire precautions, operation, maintenance, and housekeeping. These are OSHA Sections 1910.94 and 1910.107 and NFPA-33.
- ⚠ Use of spray guns may cause cumulative trauma disorders (CTD's). CTD's, when using spray guns, tend to affect the upper extremities. Factors which may increase the risk of developing a CTD include:
 1. High frequency of the activity.
 2. Excessive force, such as gripping, pinching, or pressing with the hands and fingers.
 3. Extreme or awkward finger, wrist, or arm positions.
 4. Excessive duration of the activity.
 5. Vibration.
 6. Repeated pressure on a body part.
 7. Working in cold temperatures.CTD's can also be caused by sports activities. Pain, tingling, or numbness in the shoulder, forearm, wrist, hands, or fingers, especially during the night, may be early symptoms of a CTD. Do not ignore them. Should you experience any such symptoms, see a physician immediately. Other early symptoms may include vague discomfort in the hand, loss of manual dexterity, and nonspecific pain in the arm. Ignoring early symptoms and continued repetitive use of the arm, wrist, and hand can lead to a serious disability.

SAFETY INSTRUCTIONS - DO NOT DISCARD - GIVE TO USER



⚠️ WARNING (CONTINUED)

To reduce the risk of injury, anyone using, repairing, maintaining, or changing accessories on this tool must read and understand these instructions before performing any of these tasks.

- ⚠️ Some dust created by power sanding, sawing, grinding, drilling and other construction activities contains chemicals known to the State of California to cause cancer and birth defects or other reproductive harm. Some examples of these chemicals are:
 - Lead from lead based paints
 - Crystalline silica bricks and cement and other masonry products
 - Arsenic and chromium from chemically-treated lumber
 Your risk from these exposures varies, depending on how often you do this type of work. To reduce your exposure to these chemicals: work in a well ventilated area, and work with approved safety equipment, such as those dust masks that are specially designed to filter out microscopic particles.
- ⚠️ Handling the brass parts of this product will expose you to lead, a chemical known to the State of California to cause birth defects and other reproductive harm. *Wash hands after handling.*

IMPORTANT PRECAUTION INFORMATION - READ BEFORE USING THIS SPRAY GUN:

SPRAY GUN DESCRIPTION

The 9002B Rev. A is a light weight, anodized aluminum, general purpose gravity feed spray gun designed for use in various types of spraying applications. The 9002B Rev. A can handle water based and solvent based spraying applications.

IMPORTANT: This spray gun may be used with most common coating and finishing materials. It is designed for use with mildly corrosive and non-abrasive materials. If used with other high corrosive or abrasive materials, it must be expected that frequent and thorough cleaning will be required and the necessity for replacement of parts will be increased..

For maximum transfer efficiency, do not use more pressure than is necessary to atomize the material being applied. Connect the gun to a clean, moisture and oil free air supply using a hose size of at least 5/16" I.D. hose. Do not use 1/4" I.D. hose. (25' x 1/4" hose at 18 cfm has a pressure loss of 25 psi. 25' x 5/16" hose at 18 cfm has a pressure loss of 8 psi.)

AIR SUPPLY

Air Flow CFM	Length of Pipe (ft.)			
	50	100	150	200
10	1/2"	3/4"	3/4"	3/4"
20	3/4"	3/4"	3/4"	3/4"
30	3/4"	3/4"	1"	1"
40	1"	1"	1"	1"
50	1"	1"	1"	1"
70	1"	1"	1-1/4"	1-1/4"

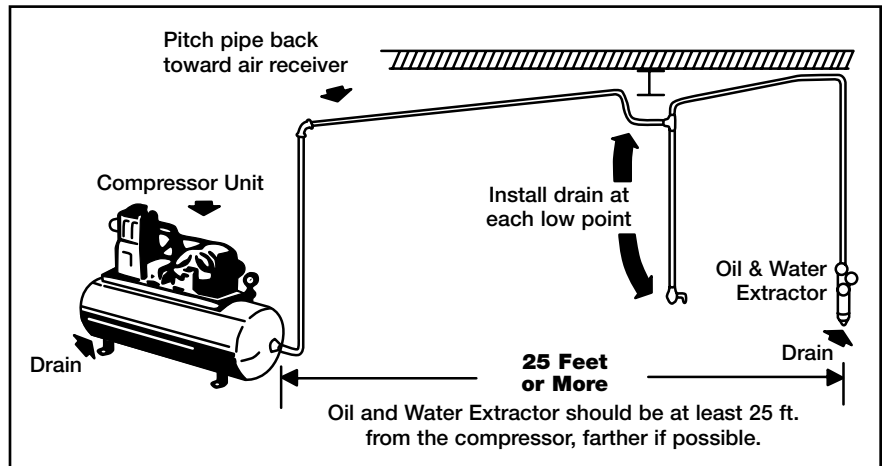

Never mount oil and water extractor on or near the air compressor.

During compression, air temperature is greatly increased. As the air cools down to room temperature, moisture condenses in the air line, on its way to the spray gun. Therefore, always mount the oil and water extractor at a point in the air supply system where the compressed air temperature is lowest.

Drain air lines properly.

Pitch all air lines back towards the compressor so that condensed moisture will flow back into the air receiver where it can be drained off. Each low point in an air line acts as a water trap. Such points should be fitted with an easily accessible drain. See diagram above.

SAFETY INSTRUCTIONS - DO NOT DISCARD - GIVE TO USER

INSTALLATION

This spray gun is rugged in construction, and is built to yield exceptional value. The life of this product and the efficiency of its operation depend upon a knowledge of its construction, use and maintenance.

GRAVITY FEED HOOKUP

Air pressure for atomization is regulated at extractor. Amount of fluid is adjusted by fluid control screw on gun, viscosity of paint, and air pressure.

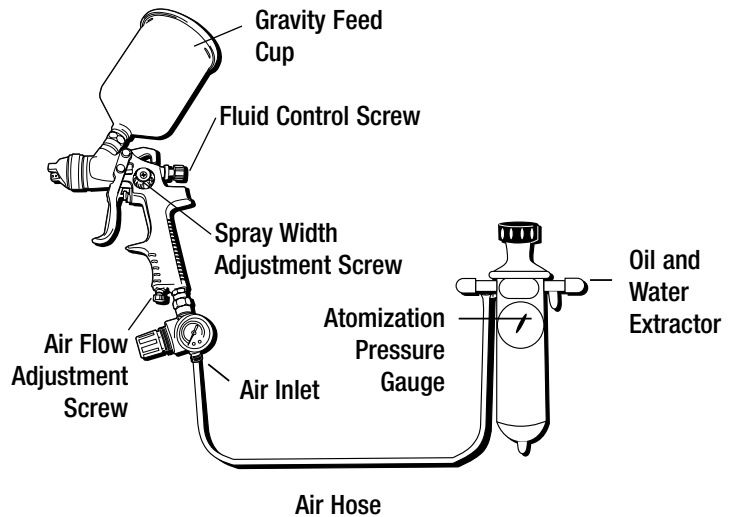

FOR BEST PERFORMANCE, PLEASE BE SURE TO DO THE FOLLOWING BEFORE USING THIS SPRAY GUN

- Tighten the gun to the cup securely with the nut and fitting supplied.
- Be sure to have the proper air pressure at the gun to operate. Proper air pressure for this tool should not exceed 50 PSI
- Adjust fluid control screw and spray width adjustment screw to your desired pattern before using on production.
- Clean all parts after use.

ADJUSTMENTS

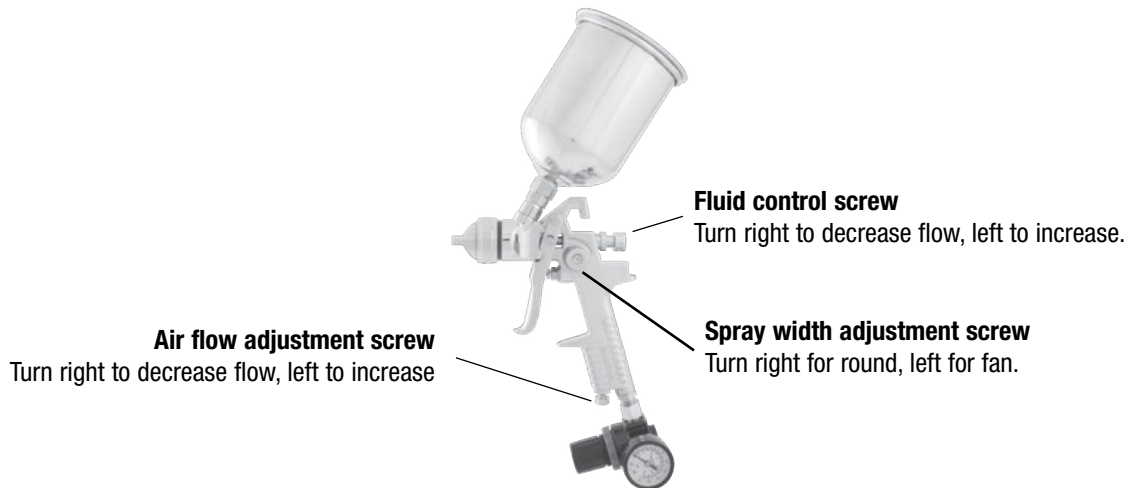

SPRAYING

In normal use, the nozzle wings are horizontal as shown here. This provides a vertical fan-shaped pattern which gives maximum, even material coverage as the gun is moved back and forth parallel to the surface being finished.

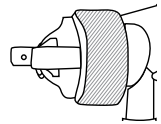

Set inlet pressure at no more than 50 PSI. For optimum performance, some materials may spray better at PSI ratings below 50 PSI. If unsure, always test at PSI ratings before using on final production. Try spray. If it is too fine, decrease the air pressure or open fluid control screw. If the spray is too thick, close the fluid control screw. Regulate the pattern width and repeat adjustment of spray as needed.

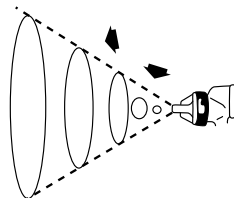

Spray pattern may be infinitely adjusted from round to flat.

OPERATION

Proper handling of the gun is essential for obtaining a good finish. The gun should be held at a right angle to the surface being covered, and moved parallel with it. For precise control of the gun and material, the trigger should be released before the end of the stroke. Hold the gun from 6 to 12 inches away from the surface depending on material and atomizing pressure. For a uniform finish, lap each stroke over the preceding stroke, making sure the spray is smooth and wet.

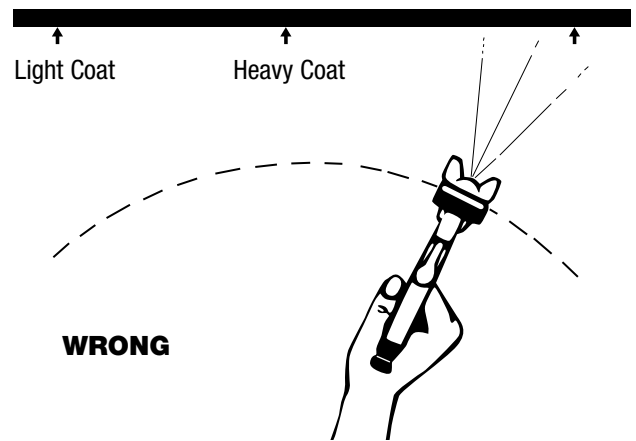
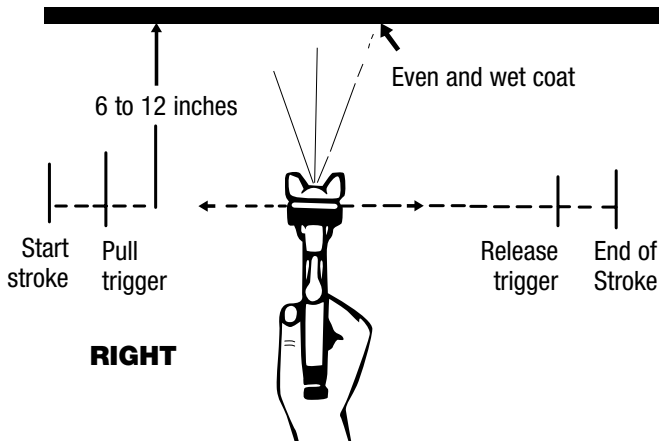

CLEANING AND MAINTENANCE

SPRAY GUN

1. Submerge the front end of the gun in solvent just until the fluid connection is covered.
 2. Paint that has built up on the gun should be removed using a bristle brush and solvent.
 3. Never submerge all of the spray gun in solvent because:
 - This will dissolve the lubricant in the packings and on wear surfaces, causing them to dry out and resulting in difficult operation and faster wear.
 - Air passages in the gun will become clogged with dirty solvent.
 4. Using a rag moistened with solvent, wipe down the outside of the gun.
 5. Oil gun daily. Use a drop of lightweight machine oil on:
 - A. fluid needle packing
 - B. air valve packing
 - C. trigger pivot point
- See Fig. 1 for Location of Above Points.
6. **NOTE:** Do not soak rubber o-rings or seals in paint thinner. O-rings and seals can be wiped clean with paint thinner but soaking can cause these items to deteriorate over time.
 7. **Caution:** Do not use lubricants which contain silicone. Silicone may cause defects in the finish application.

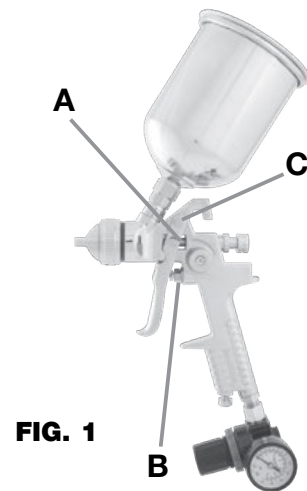

CAUTION...

To avoid cross-threading, all spray gun parts should be screwed in hand tight initially. If the parts can not easily be turned by hand, be sure you have the correct parts, unscrew, realign, and try again. NEVER use excessive force in matching parts.

AIR NOZZLE, FLUID NOZZLE, AIR VALVE ASSEMBLY

1. All nozzles and needles are made to exact standards. They should be handled carefully.
2. To clean nozzles, immerse them in solvent until any dried material is dissolved, then blow them clean.
3. Do not use metal or sharp instrument to probe any of the holes in the nozzles.
4. Air flow should occur before fluid-flow when the gun is triggered. It may be necessary to adjust the fluid control screw to make sure air flows before fluid.
5. Do not alter the gun in any way.

GRAVITY FEED

Turn off air supply. Remove cover of cup. Empty the cup of material. Clean the cup and cover. Turn on air supply and spray with proper cleaning solvent. Repeat with clean solvent if necessary. Remove solvent, disconnect gun, remove air cap and clean. Wipe gun and cup with rag dampened with solvent.

TROUBLESHOOTING

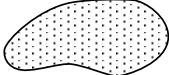
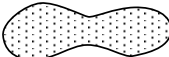
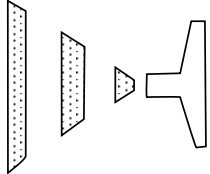
SPRAY PATTERN/ CONDITION	PROBLEM	SOLUTION
	One side of nozzle wing is clogged.	Soak nozzle in solvent to loosen clog, then blow air through until clean. To clean orifices use a broom straw or toothpick. Never try and detach dried material with sharp tool.
	A.) Loose air nozzle. B.) Material around outside of air nozzle has dried.	A.) Tighten air nozzle. B.) Take off air nozzle and wipe off fluid tip, using rag moistened with thinner.
	A.) Atomization air pressure is set too high. B.) Trying to spray a thin material in too wide a pattern.	A.) Reduce air pressure. B.) Increase material control by turning fluid control screw to left, while reducing spray width by turning spray width adjustment screw to right.
 <p style="text-align: center;">Spitting</p>	A.) Packing around needle valve is dried out. B.) Fluid nozzle loosely installed, or dirt between nozzle and body. C.) Loose or defective swivel nut on siphon cup.	A.) Back up knurled nut, put a few drops of machine oil on packing, re-tighten nut. B.) Take off fluid nozzle, clean rear of nozzle and seat in gun body. Replace nozzle and bring in tight to body. C.) Tighten or change out swivel nut.
<p>Improper spray pattern.</p>	A.) Gun improperly adjusted. B.) Dirty air cap. C.) Fluid tip obstructed. D.) Sluggish needle.	A.) Readjust gun. Follow instructions carefully. B.) Clean air cap. C.) Clean. D.) Lubricate.
<p>Unable to get round spray.</p>	Fan adjustment screw not seating properly.	Clean or replace.
<p>Will not spray.</p>	A.) No air pressure at gun. B.) Fluid pressure too low with internal mix cap and pressure tank. C.) Fluid control screw not open enough. D.) Fluid too heavy.	A.) Check air supply and air lines. B.) Increase fluid pressure at tank. C.) Open fluid control screw. D.) Thin material or change to pressure feed.
<p>Fluid leakage from packing nut.</p>	A.) Packing nut loose. B.) Packing worn or dry.	A.) Tighten, but not so tight as to grip needle. B.) Replace packing or lubricate.
<p>Dripping from fluid tip.</p>	A.) Dry packing. B.) Sluggish needle. C.) Tight packing nut. D.) Worn fluid nozzle or needle.	A.) Lubricate. B.) Lubricate. C.) Adjust. D.) For pressure feed, replace with new fluid nozzle and needle.
<p>Thin, sandy coarse finish.</p>	A.) Gun held too far from surface. B.) Atomization pressure set too high.	A.) Move gun closer to surface. B.) Adjust atomization pressure.
<p>Thick, dimpled finish resembling orange peel.</p>	Gun held too close to surface.	Move gun further from surface.

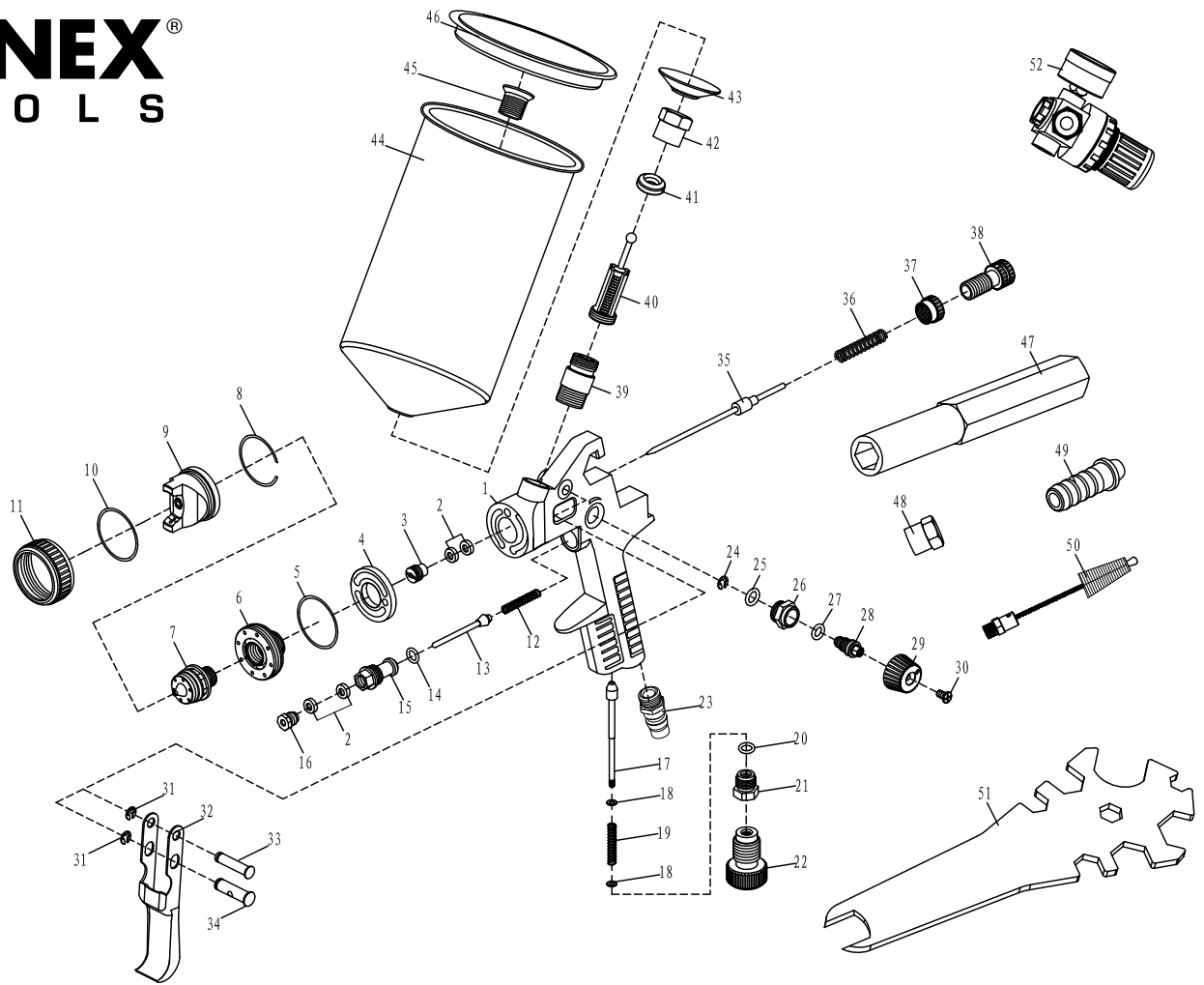

REF. NO.	DESCRIPTION	QTY.	REF. NO.	DESCRIPTION	QTY.	REF. NO.	DESCRIPTION	QTY.
1	Gun Body	1	19	Air Flow Adjustment Spring	1	37	Needle Adjustment Seat	1
2	Gasket	4	20	O-Ring 2.5 x 1.8	1	38	Needle Adjustment Knob	1
3	Sealing Screw	1	21	Air Flow Adjustment Seat	1	39	Material Passage Connector	1
4	Airflow Separating Ring	1	22	Air Flow Adjustment Knob	1	40	Filter	1
5	Nozzle Seat Gasket	1	23	Air Joint	1	41	Sealing Gasket	1
6	Nozzle Seat	1	24	Opening Stopper	1	42	Fluid Connector	1
7	Material Nozzle	1	25	O-Ring 5.3 x 1.5	1	43	Gasket	1
8	Air Nozzle Circlip	1	26	Pattern Adjustment Seat	1	44	Cup	1
9	Air Nozzle	1	27	O-Ring 6 x 1.8	1	45	Screw	1
10	Air Nozzle Gasket	1	28	Pattern Adjustment Stem	1	46	Cup Cover	1
11	Air Cap	1	29	Pattern Adjustment Knob	1	47	Hex Wrench	1
12	Air Valve Spring	1	30	Cross Recess Nut	1	48	Hex Connector Nut	1
13	Air Valve Stem	1	31	Opening Stopper 4	2	49	Connector	1
14	Sealing Gasket	1	32	Trigger	1	50	Brush	1
15	Air Valve Body	1	33	Trigger Pin	1	51	Spanner Wrench	1
16	Sealing Nut	1	34	Flexible Pin	1	52	Regulator	1
17	Air Flow Adustment Stem	1	35	Needle	1			
18	Gasket	2	36	Needle Adj. Spring	1			

Only items identified by part numbers are available separately.

Parts Available:

9091: Regulator (Item #52)

Replacement Parts Available:

RS9002BRK: Repair Kit (incl. #2, 5, 13-15, 18, 20, 25, 27, 41)

RS9002BNK: Air Nozzle/Fluid Nozzle/Needle Kit (incl. #8-11, 35, 36)

RS9002BF: Filter (set of 5) #40

RS9002BSW: Spray Width Assy. incl. #26, 28-30)

RS9002BAF: Air Flow Assy. (incl. #17-22)