



**SUNEX<sup>®</sup>**  
**T O O L S**

MODEL 8019 Deluxe Work Table

**PARTS BREAKDOWN AND OPERATING MANUAL**

**Tools Needed to Assemble Unit:**

- 17mm Wrench
- 14mm Wrench

**PARTS LIST:**

Part#	Description	Qty.
1.	Top Tray	1
2.	Rubber Corner Bumper w/Pins	4
3.	Small Plastic Insert	4
4.	14mm Bolt with Washer	12
5.	Adjustable Tube (silver)	1
6.	T-Bolt	1
7.	Right support	1
8.	Large Plastic Insert	4
9.	2" Caster with Nut	4
10.	Tube Support	1
11.	Left Support	1
12.	17mm Bolt with Curved Washer	1
13.	Ball Bearing Slide	2
14.	Drawer Unit	1
15.	Aluminum Handle	1

**SPECIFICATIONS:**

Overall Tray Dimensions: .....28-7/8" x 19-7/8" x 1"  
 Main Tray Area: .....28"-1/2" x 16-7/8" x 1"  
 Small Compartments .....9-1/2" x 2-3/4" x 1"

1.5mm gauge steel

Low Height:..... 34"  
 High Height: ..... 47-3/4"  
 Overall Length:..... 32-3/4"  
 Overall Width:..... 20-3/8"  
 Shipping Weight:..... 39.7 lbs.

**ASSEMBLY INSTRUCTIONS**

1. Using four 14mm bolts, washer and nuts, install one caster in each square hole on the bottom edge support (#7 & #11). Be sure the square bolster on the post of each caster inserts fully into the square hole in the support before fully tightening.
2. Using four 14mm bolts and washers, attach the bolt plate on the right support (#7) to the bracket on the tube support (#10), ensuring that the casters are facing down. Be sure bolts are securely tightened before proceeding.
3. Slide left support tube (#11) into the tube support (#10) and secure with 17mm bolt and curved washer (#12). The curved washer should conform to the tubing wall.
4. Laying the top tray (#1) upside down on the floor, attach the mounting bracket on silver adjusting tube (#5) to the bracket on the bottom of the tray, being sure the adjusting tube faces AWAY from the center of the top tray.
5. Now, slide the silver adjusting tube with top tray attached into the tube support (#10) and secure at the desired height with the T-bolt (#6).
6. Attach four rubber protector bumpers (#2) by pushing the black plastic pins provided into the holes in the corners of the top tray. The pins are inserted from OUTSIDE the tray toward the inside, being sure the rubber bumpers overlap the top edge of the tray.
7. Install the four small rectangular plastic inserts (#3) into the reinforcement bars under top tray. Install the four large rectangular plastic inserts (#8) into the four holes on the left and right supports (#7 & #11).

You are now ready to use your Sunex Model 8019 Deluxe work table.

**CAUTION:**  
 DO NOT EXCEED THE 220 LBS.  
 (100 KGS.) RATED CAPACITY

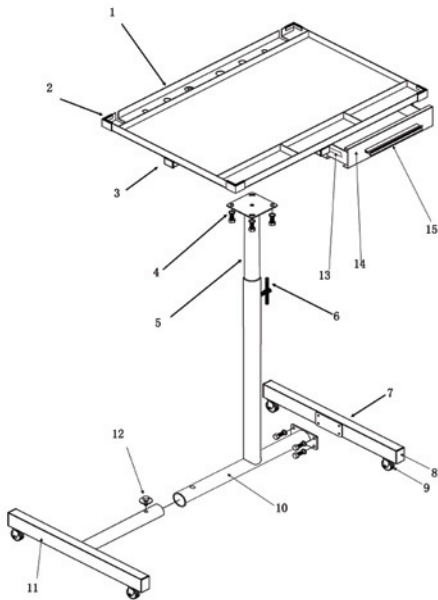

**NOTE:** Only Part #9 available separately as RS8018CS caster with nut.