

**OPERATING MANUAL**



Read and follow all instructions in User's Manual. It is the responsibility of the owner to make sure all personnel read this manual prior to using the device. It is also the responsibility of the device owner to keep this manual intact and in a convenient location for all to see and read. If the manual or product labels are lost or not legible, contact Sunex Tools® for replacements. If the operator is not fluent in English, the product and safety instructions shall be read and discussed with the operator in the operator's native language by the purchaser/owner or his designee, making sure that the operator comprehends its contents.

**ASSEMBLY INSTRUCTIONS**

Examine box contents, then proceed with following instructions.

- Step 1:** Slide chrome legs (#2) into square holes cut in tray (#1) until bolt holes are aligned at top of legs.
- Step 2:** Insert bolt and flat washer into hole on leg and tray. Fasten nut using lock washer and flat washer, **BUT DO NOT TIGHTEN NOT COMPLETELY AT THIS TIME.** Repeat this procedure on all four corners.
- Step 3:** Repeat Step 1 with bottom tray (#1).
- Step 4:** Repeat Step 2 with bottom tray (#1).
- Step 5:** Insert casters (#3, #4) into the hole of plastic inserts (#5). **NOTE:** Insert the two locking casters (#3) at the same end of the cart.
- Step 6:** Now go back and tighten all loose nuts and bolts (Torque to 60 inch-lbs.).
- Step 7:** For drawer assembly instructions, if this feature is available with model purchased, go to Step 8 on reverse side.

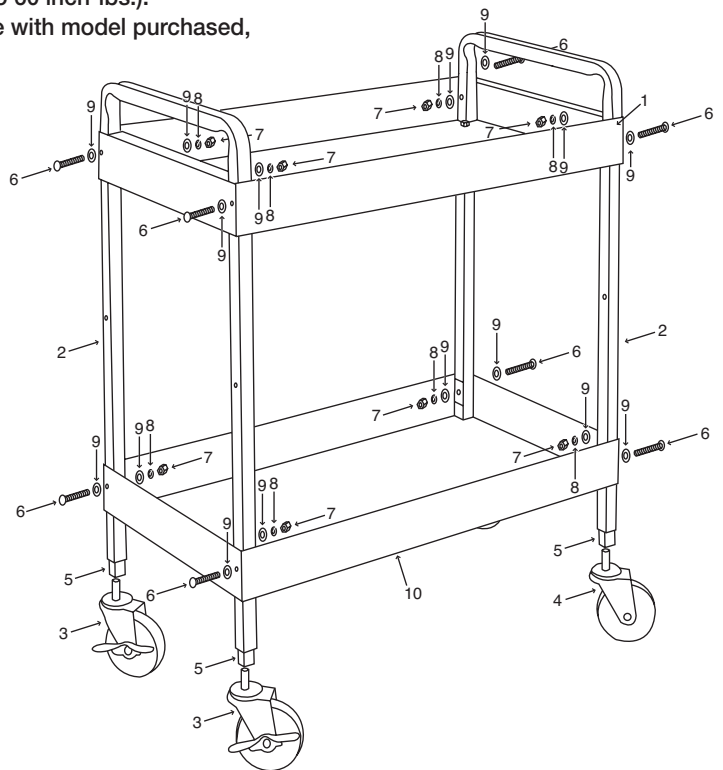
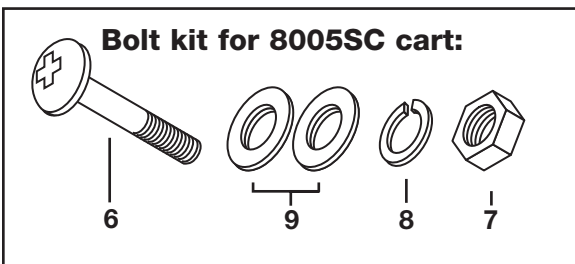

**WARNING**



Read and follow all instructions in User's Manual. • Do not load carts beyond rated capacity 350 lbs. (175 lbs. per shelf) • Lock lid and drawers before moving. • Apply brake on locking casters anytime cart is in place. • Units can tip or fall causing damage or personal injury. • Cart is designed to roll easily on flat surfaces and should not be used on uneven or inclined surfaces. • Do not open more than one loaded drawer at a time. • Do not stand on or step in drawers. • Keep children away from unit. • Wear gloves when lifting edges. • This product may contain one or more chemicals known to the State of California to cause cancer and birth defects or other reproductive harm. *Wash hands thoroughly after handling.* • Failure to heed these warnings may result in personal injury and/or property damage.

**REPLACEMENT PARTS LIST**

Item#	Part#	Description #	Req.
1	8007	Tray/each	2
2	RSSC7	Chrome Leg/each	2
3	RSSCPLW	Locking Caster/each	2
4	RSSCPW	Non-Locking Casters/each	2
5	RSSCPP1	Set of 4 Plastic Inserts	1
	RSSCPHK	Bolt Kit (Incl. 8 each of #6, 7, 8 and 16 each of #9)	1

**Also Available:**

8006RB	Locking Drawer with Roller Bearing Slides
RSRBSLIDEC2	Clip-on Roller Bearing Slides/pr.
RS8006HDL	Chrome Drawer Handle
RS8006LK	Drawer Lock with Two Keys
RSDECAL01	Black logo decal (not shown)

**ASSEMBLY INSTRUCTIONS FOR LOCKING DRAWER**

Examine box contents, then proceed with following instructions.

Tools Needed for Assembly:

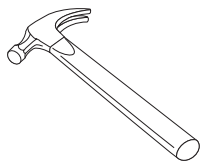

#3 Phillips Head  
Screwdriver

Hardware included for attaching drawer to cart:



(6 per unit)



(6 per unit)



(12 per unit)



(4 per unit)

- Step 8:** With the cart fully assembled, take a small punch and hammer, and gently knock out the 4 pre-scored dimples in the top tray.
- Step 9:** Turn the cart on its handles as shown in drawing B. You will see the 4 holes that you knocked out.
- Step 10:** Disassemble the locking drawer (if not already disassembled) by removing all bolts. Product must match illustration A before proceeding to Step 11.
- Step 11:** Line up the holes on the back of the shelf with part #1A, the left side of the drawer cabinet as shown in drawing B. Part 1A and 2 overlap and connect as shown in drawing C. Insert bolts and washers **from underneath** the shelf and washers and nuts on other side. Do not completely tighten the nut at this time.
- Step 12:** Line up the holes on the back of the shelf with part #1B, the right side of the drawer cabinet and the other end of part #2, the back plate of the drawer cabinet. Insert bolts and washers from underneath the shelf and washers and nuts on other side. Do not completely tighten the nut at this time.
- Step 13:** Line up the holes on part #3, the front panel of the drawer cabinet, with the other end of 1A, 1B, and the front end of the shelf. Place part #3 under 1A & 1B, and attach to the shelf. Insert bolts and washers **from underneath** the shelf and washers and nuts on other side. Do not completely tighten the nut at this time.
- Step 14:** Turn the cart back on its casters.
- Step 15:** Attach the handle to the front of the drawer with the 4 screws provided. The 4 holes on the front of the drawer have already been drilled out for you.
- Step 16:** Before inserting the drawer into the service cart cabinet, make sure the roller bearing case is extended all the way out to the black plastic end stop. (This ensures proper alignment during insertion.) Hold the roller bearing case in place while inserting drawer. If necessary, adjust the drawer rails (items 1A and 1B) to allow the drawer to slide on smoothly. Once you have determined the width which allows the drawer to slide in and out smoothly refer back to steps 11, 12, and 13 to tighten the nuts down completely.

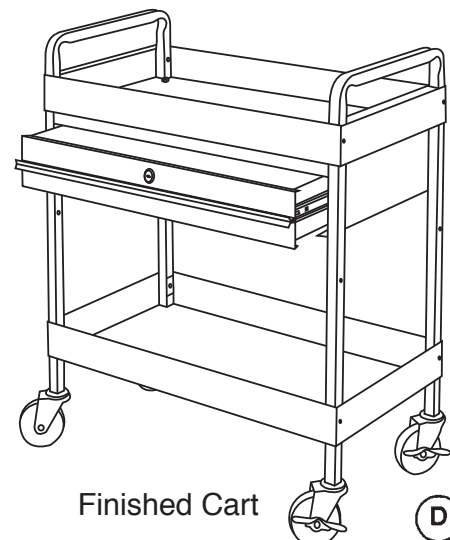
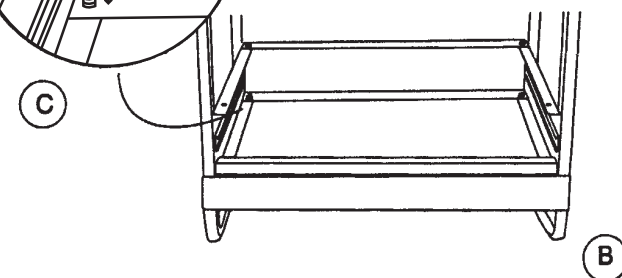
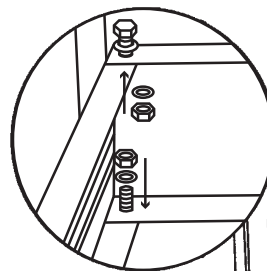
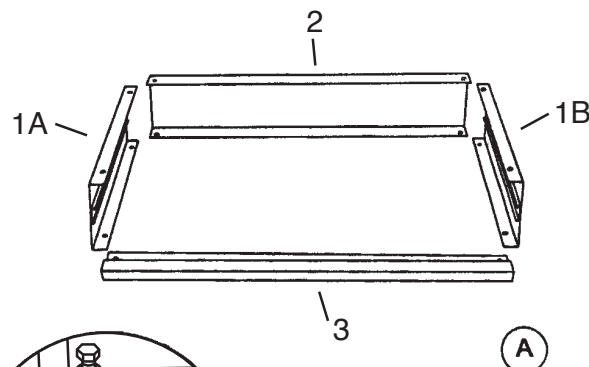

**CAUTION:** DO NOT FORCE THE DRAWER ONTO THE SLIDE RAILS. This may cause permanent damage to the slide roller bearings.