

#1. Top Shelf

(4 knockout dimples in bottom of tray for optional locking drawer, 8006RB)

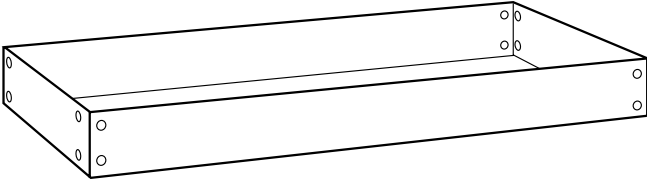

#2. Bottom Shelf

(16 pre-drilled holes in bottom of tray for attaching casters)

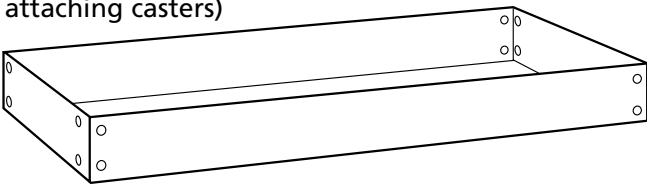

#3. Non-locking Caster (x2)

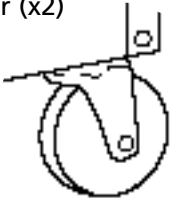

#4. Locking Caster (x2)

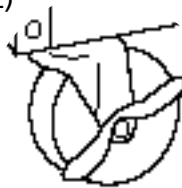

#5. Leg (x4)

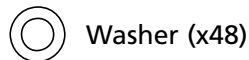
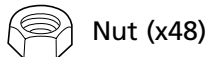

#7. Bolt Kit contains:
 28 short bolts, nuts, and washers for the legs.

#8. Bolt Kit contains:
 4 long bolts, nuts and washers for the handle.

#9. Bolt Kit contains:
 16 short bolts, nuts, and washers for the casters.

#6. Handle

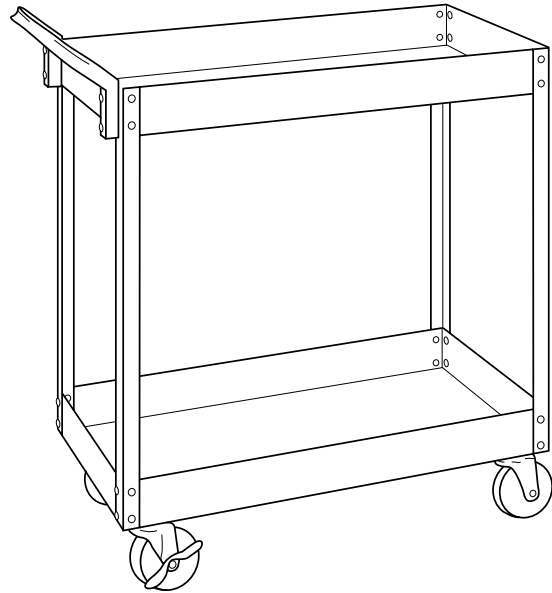
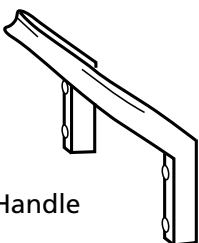

Items Needed for Assembly:

#2 Phillips head screwdriver

10mm wrench

Assembly Instructions:

1. Using a 10mm size wrench, Phillips head screwdriver, and part #9 (bolt kit containing 16 short bolts, nuts and washers), attach part #3 (2 non-locking casters) and part #4 (2 locking casters) to each end of part #2 (bottom shelf with 16 pre-drilled holes).

2. Using the 10mm size wrench, Phillips head screwdriver, and part #7 (bolt kit 16 pieces of the 28 short bolts, nuts and washers), attach part #5 (4 legs) to part #2 (bottom shelf).

3. Using the 10mm size wrench, Phillips head screwdriver, and part #7 (bolt kit –remaining 12 pcs. of the 28 short bolts, nuts, and washers) attach part #1 (top shelf) to the legs and bottom shelf.

Note: In order to place the handle on the same end as the locking casters, leave the 4 outside holes open on the locking caster end of the cart. Follow step 4 below and attach the handle.

4. Using the 10mm size wrench, Phillips head screwdriver, and part #8 (bolt kit – 4 long bolts, nuts, and washers) attach part #6 (handle) to the cart.

Replacement Parts Available:

RS8003LC Locking Caster (ea.)

RS8003SC Non-locking Caster (ea.)

RS8003CHDL Chrome Handle