

WARNING

DO NOT connect generator to a building's electrical system without the proper installation of a double throw transfer switch by a qualified electrician. The installation must isolate the generator power from the utility power and must comply with all applicable laws and electrical codes.

Failure to isolate the generator power from the utility power can result in death or injury to electric utility workers due to backfeed of electricity.

⚠ DANGER

Using a generator indoors **CAN KILL YOU IN MINUTES**. Generator exhaust contains carbon monoxide. This is a poison you cannot see or smell.

NEVER use inside a home or garage, **EVEN IF** doors and windows are open.

Only use **OUTSIDE** and far away from windows, doors, and vents.

LOOK BEFORE YOU PUMP!

Ethanol Percentage

<10% OK NO 15%–30%–85%

DO NOT USE FUEL CONTAINING GREATER THAN 10% ETHANOL!
N'UTILISEZ PAS UN CARBURANT DONT LA TENEUR EN ÉTHANOL EST SUPÉRIEURE À 10%!
¡NO UTILICE COMBUSTIBLES QUE CONTENGAN MÁS DE 10% DE ETANOL!

ASSEMBLY

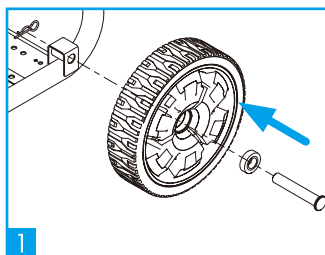

1 Install wheels.

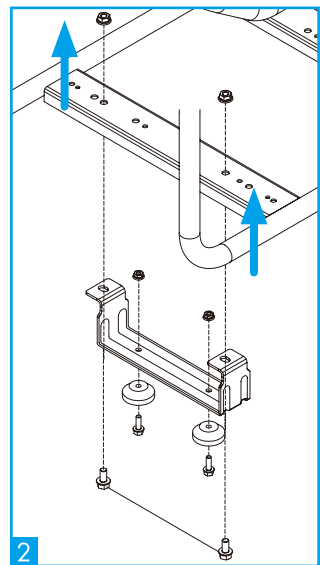

2 Install support bracket and damping feet.

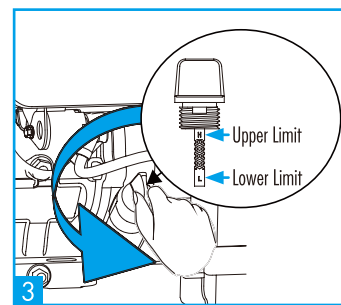

3 Add oil to the upper limit mark on dipstick.

WARNING: This Quick Reference Guide is not a substitute for reading the operator's manual. To reduce the risk of injury, read and understand the generator operator's manuals before using this product.

STARTING (PLEASE REGISTER THE PRODUCT BEFORE STARTING)

RECOIL STARTING/STOPPING

STARTING

1 Check/fill engine oil.

2 Check/fill engine fuel.

3 Verify the fuel valve is in ON position.

4 Move the choke to the CLOSED position.

5 Place the START switch in the ON position. Pull back recoil forcefully until the engine starts.

6 Move the choke to the OPEN position.

7 Connect electrical devices.

STOPPING

1 Disconnect electrical devices.

2 Turn switch OFF.

3 Turn fuel valve to OFF position.

ELECTRIC STARTING/STOPPING

STARTING

1 Check/fill engine oil.

2 Check/fill engine fuel.

3 Verify the fuel valve is in the ON position.

4 Move the choke to the CLOSED position.

5 Turn key to START (Once started, release key)

6 Move the choke to the OPEN position.

7 Connect electrical devices.

STOPPING

1 Disconnect electrical devices.

2 Turn key to OFF (Once off, release key)

3 Turn fuel valve to OFF position.

OPERATION

USING THE GENERATOR

1. Make sure the generator can supply enough running and starting watts for the items you will power at the same time.
2. Start the generator without power cords connected.
3. Plug in and turn on the first load, preferably the largest load you have.
4. Allow the generator output to stabilize (engine runs smoothly and attached device operates properly).
5. Plug in and turn on the next load.
6. Again, allow the generator to stabilize.
7. Repeat previous two steps for each additional load. **IMPORTANT:** Never add more loads than the generator capacity. Take special care to consider surge loads in generator capacity.

TROUBLESHOOTING

PROBLEM	POSSIBLE CAUSE	SOLUTION
Engine will not start	No fuel	Fill fuel tank.
	Stale gasoline or water in gasoline.	Drain entire system and refill with fresh fuel
	Oil level is low.	Engine is equipped with protection shutdown when oil level is too low. Check oil level and fill as necessary.
	Fuel valve is in OFF position.	Turn fuel valve to ON position.
	Spark plug is faulty, fouled or improperly gapped.	Replace spark plug.
Engine will not start	Choke is open and therefore in OFF position.	Close the choke to ON position.
	Engine stored without treating or draining gasoline, or refueled with bad gasoline.	Drain fuel tank and carburetor. Refuel with fresh gasoline.
Engine lacks power	Water in gasoline.	Drain entire system and refill with fresh fuel.
	Weak spark at spark plug.	Inspect spark plug and replace if necessary.
AC receptacle does not work	Engine stored without treating or draining gasoline, or refueled with bad gasoline.	Drain fuel and carburetor. Refuel with fresh gasoline.
	Circuit breaker is OFF.	Turn ON the AC circuit breaker.
Generator makes a "spark knock" or "pinging" noise	Connected device is not working.	Connect a different device to test.
	An occasional light "knocking" or "pinging" under heavy load is not a cause for concern. However, if the knocking or pinging occurs under normal load at steady engine speed, there may be a problem with gasoline quality.	Switch to a brand of gasoline with an octane rating of 86 or higher.