

# CRIMPER FOR OPEN BARREL TERMINALS (AWG 10-26)

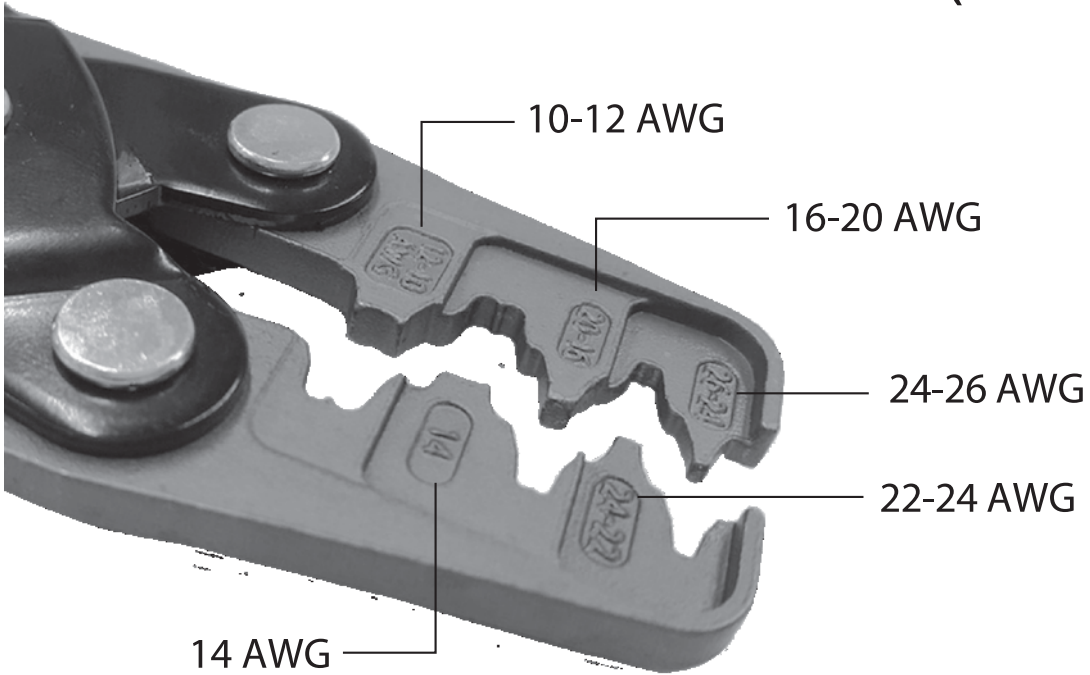

## INSTRUCTIONS

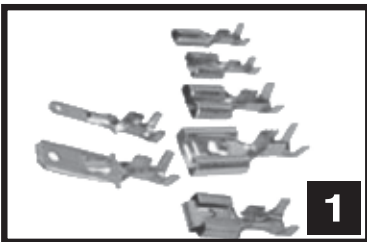

Crimp open barrel terminals from 10-26 AWG



Insert the terminal into the appropriate cavity to make the "B" crimp on the tabs over the uninsulated portion of the wire. Gently close the jaws to hold the terminal in place. The rounded side of the terminal is placed on the shorter, rounded groove of the jaw.



Insert the stripped wire into the terminal. Completely close the jaws to crimp the terminal. Squeeze the handles together to form the first crimp.



Insert the insulated portion of the wire into the appropriate cavity and squeeze the handles to form the tabs around the insulation.



Pull test to ensure a secure crimp.

