

## INSTRUCTIONS FOR GENERAL USE

1. Use oil specified by air tool manufacturer.
2. Do not use motor, brake, power steering or transmission oil.
3. Do not fill with thinner, paints or solvents.
4. Hand tighten ONLY!
5. Maximum air pressure 175 P.S.I.

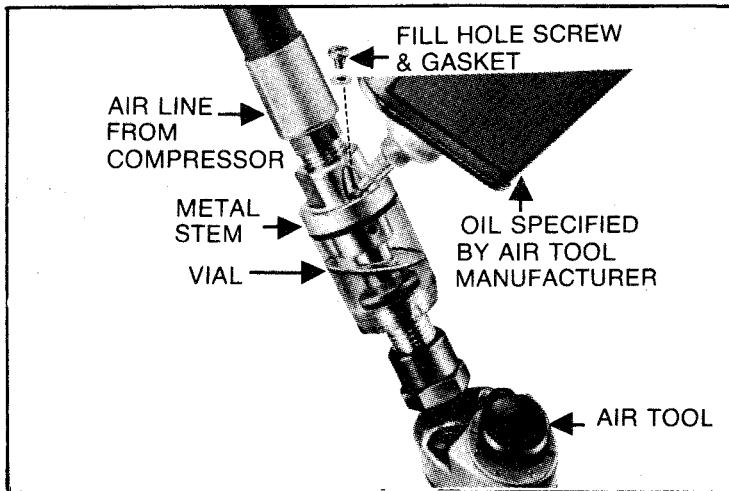

## INSTRUCTIONS FOR FILLING

1. Turn off air. Remove screw and gasket from fill hole.
  2. Unscrew vial about 1/4 turn to provide slight opening between "O" ring on end of vial and metal stem.
  3. Insert tip of oil can spout into fill hole as shown and fill vial with oil.
  4. Screw vial fully closed. Hand tighten ONLY! Be sure "O" ring completely contacts and seats on metal stem.
  5. Replace gasket and screw securely into fill hole. Turn on air. The "OILER" is now ready for use again.
  6. A fine mist of precisely metered oil will now enter your air tool with each use, coating and lubricating all internal moving parts. The "OILER" will protect your tool by reducing friction and guarding against rust. Remove "OILER" from air tool when not in use.
  7. Oil is consumed at a slight rate. You may not notice any consumption during the first hours of operation.
  8. When removed from tool, store Oiler with air inlet up to prevent oil loss.
- U.S. PAT. NO. 3,807,530

[View other air tools accessories made by S&G Tool Aid on our website.](#)