

Raynger® ST™

ST60 ProPlus™ Standard
ST80 ProPlus™ Enhanced

Noncontact Thermometer

Raytek®



Table of Contents

Unit diagram	1
English	2
German Translation	15
French Translation	28
Spanish Translation	41
Portuguese Translation	54
Chinese Translation	67
Japanese Translation	80

Specifications

Temperature range	D : S*
ST60 ProPlus™	-32 to 600°C (-25 to 1100°F) 30 : 1
ST80 ProPlus™	-32 to 760°C (-25 to 1400°F) 50 : 1
Contact Probe	-40 to 260°C (-40 to 500°F)
Display Resolution	0.1°C (0.1°F)
Accuracy	For targets:
(infrared -- assumes ambient operating temp. of 23-25°C[73-77°F] @ calibration geometry**	Above 23°C (73°F): ± 1% of reading or ± 1°C (± 2°F), whichever is greater -18 to 23°C (0 to 73°F): ± 2°C (± 3°F) -26 to -18°C (-15 to 0°F): ± 2.5°C (± 4°F) -32 to -26°C (-25 to -15°F): ± 3°C (± 5°F) ≤ ± 1°C (± 2°F) or 1% of reading, whichever is greater
Probe	
Repeatability	± 1°C (± 2°F), or ± 0.5% of reading, whichever is greater
Response time	500 mSec
Spectral response	8–14 μm
Emissivity	Digitally adjustable from 0.10 to 1.0
Ambient operating range	0 to 50°C (32 to 120°F)
Laser Max	Laser turns off above 40°C (104°F) ambient temperature
Relative humidity	10–95% RH noncondensing, at < 30°C (86°F) ambient
Storage temperature	-20 to 60°C (-13 to 158°F) without battery
Weight / Dimensions	320g (11oz); 200 x 160 x 55 mm (8 X 6 X 2 in)
Power	9V Alkaline or NiCd battery
Typical Battery life (Alkaline)	20 hours with laser and backlight on 50% 40 hours laser and backlight off
Tripod Mount	1/4" 20 UNC threading

*90% encircled energy at the focal point. (Focal point = 914mm (36 inches)).

**Unit is calibrated at 279.4mm (11 in) away from 139.7mm (5.5 in) diameter, 0.95 emissivity blackbody.

Some Noncontact Thermometer Uses

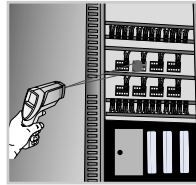

Electrical/Industrial

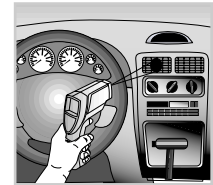
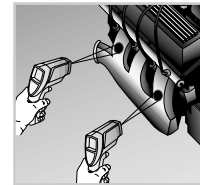
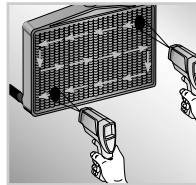
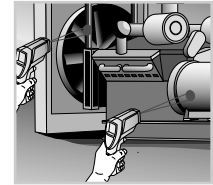
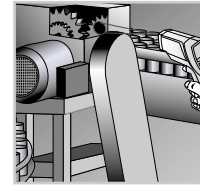

Automotive & Diesel



Food Safety

• Display



• Laser

• °C/°F Switch

• Trigger

• Lock ON/Off Switch

• Battery Compartment

• Battery Cover

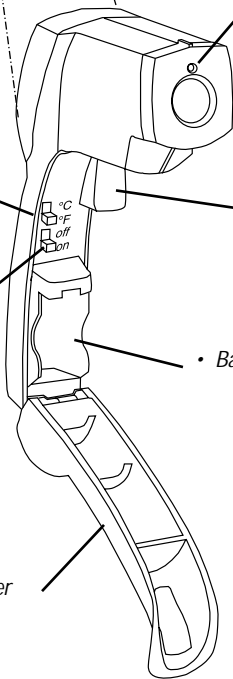



Warning

Do not point laser directly at eye or indirectly off reflective surfaces.

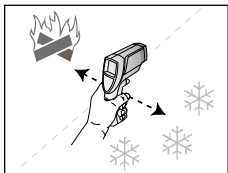

Cautions

All models should be protected from the following:

- ▲ EMF (electro-magnetic fields) from arc welders, induction heaters, etc
- ▲ Static electricity
- ▲ Thermal shock (caused by large or abrupt ambient temperature changes—allow 30 minutes for unit to stabilize before use)
- ▲ Do not leave the unit on or near objects of high temperature

Features

Your thermometer includes:

- Circular laser sighting
- Adjustable emissivity
- High and low alarm
- MAX, MIN, DIF, AVG temperature displays
- Data logging
- Trigger lock
- Backlit display
- Contact probe jack
- Hard case and wrist strap



Accessories

The optional accessories for your thermometer are:

- Contact probe (RTD)
- Nylon Holster
- NIST/DKD certification

Circular Laser Sighting

The circular laser is made up of eight laser spots that form a circle to show the approximate area being measured; a single laser spot shows the center of the measurement area. In low-light conditions, lighter spots surrounding the laser circle may appear. These spots are not used for aiming purposes. Use only the laser circle to aim the unit.

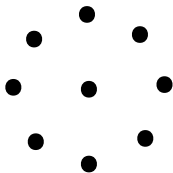

User Interface

Display

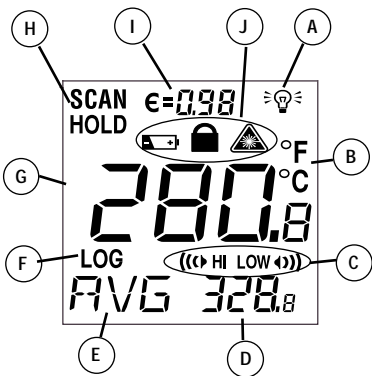

- Backlight "On" symbol
- °F/°C symbol
- High Alarm and Low Alarm symbol
- Temperature values for the MAX, MIN, DIF, AVG, HAL (high alarm), LAL (low alarm), and logged temperatures
- Symbols for MAX, MIN, DIF, AVG, HAL, LAL, PRB, and
- LOG icon shows log Mode for data storage
- Current temperature value
- SCAN or HOLD
- Emissivity symbol and value
- Low Battery, lock "On", and laser "On" symbols

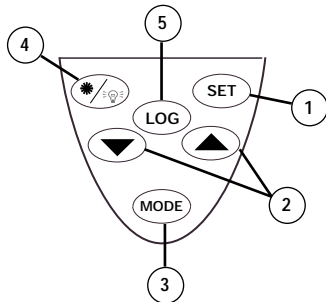

Buttons

- SET button (for setting the high alarm and low alarm)
- Up and Down buttons
- MODE button (for cycling through the Mode loop)
- Laser/Backlight on/off button (pull trigger and press button to activate laser/backlight)
- LOG button (for storing data)

In SCAN mode, the LCD displays both the current temperature (G) and selected Mode function (D, E) in Celsius or Fahrenheit (B). The unit will HOLD the last reading for 7 seconds after the trigger is released; the word HOLD appears (H). When the battery is low, the battery icon is displayed, but the unit will continue to function; when the battery is dead, the display will blank, and the unit will no longer function. To activate the laser and backlight, pull the trigger. Press the laser/backlight button (4) once to activate the backlight, twice to turn both laser and backlight on, and a third time to turn them off.

Introduction

We are confident you will find many uses for your handheld noncontact thermometer. Compact, rugged, and easy to use—just aim, pull the trigger, and read the temperature in less than a second. You can safely measure surface temperatures of hot, hazardous, moving, or hard-to-reach objects without contact.



How it Works

Infrared thermometers measure the surface temperature of an opaque object. The unit's optics sense emitted, reflected, and transmitted energy, which are collected and focused onto a detector. The unit's electronics translate the information into a temperature reading which is displayed on the unit. The laser is used for aiming purposes only.

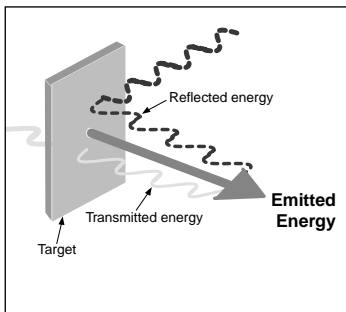

How to Operate the Unit

Measurement: Quick Start

To measure a temperature, point the unit at an object, and pull the trigger. Be sure to consider distance-to-spot size ratio and field of view. The laser is used for aiming only. For more detailed operating instructions, see "How to Accurately Measure Temperatures."

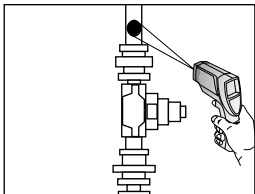

Switching °C and °F; Locking the Unit on; Changing the Battery

To open the unit's handle, push the button on the underside of the unit near the trigger, and pull down and forward at the top of the unit's handle. To toggle between °C and °F, slide the top switch (A) to the appropriate position.

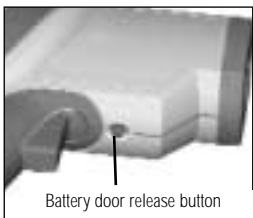

Battery door release button

To lock the unit on for continuous measurement, slide the bottom switch (B) down. If the trigger is pulled while the unit is locked on, the laser and backlight will turn on if they have been activated (see "User Interface" for instructions on activating the laser and backlight). When the unit is locked on, the laser will turn off when the trigger is released; however, the backlight will remain on unless it is turned off using the Laser/Backlight button on the keypad.

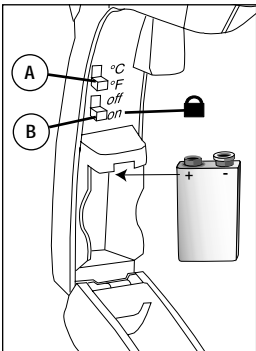

To change the 9V battery, insert it with the positive side toward the rear of the battery compartment.

How to Accurately Measure Temperature

Locating a Hot or Cold Spot

To find a hot or cold spot, aim the thermometer outside the area of interest. Then slowly scan across the area with an up and down motion until you locate the hot or cold spot.

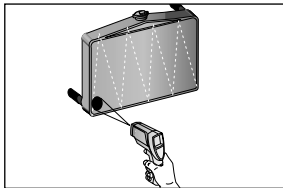

Field of View

Make sure that the target is larger than the unit's spot size. The smaller the target, the closer you should be to it. (See the diagram on the side of the unit.)

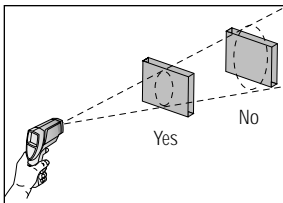

Emissivity

Emissivity is a term used to describe the energy-emitting characteristics of materials. Most organic materials and painted or oxidized surfaces have an emissivity of 0.95. Inaccurate readings can result from measuring shiny or polished metal surfaces. To compensate for this, adjust the unit's emissivity reading (see "Setting the High Alarm, Low Alarm, and Emissivity"), or cover the surface to be measured with masking tape or flat black paint (< 300°F/148°C). Allow time for the tape or paint to reach the same temperature as the material underneath it. Measure the temperature of the tape or painted surface.

Distance & Spot Size

As the distance (D) from the object increases, the spot size (S) of the area measured by the unit becomes larger. The relationship between distance and spot size for each unit is listed below. The focal point for each unit is 914mm (36"). The spot sizes indicate 90% encircled energy.

Standard Model

D:S = 30:1

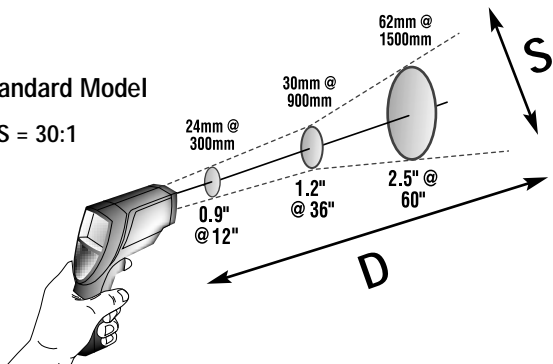

Enhanced Model

D:S = 50:1

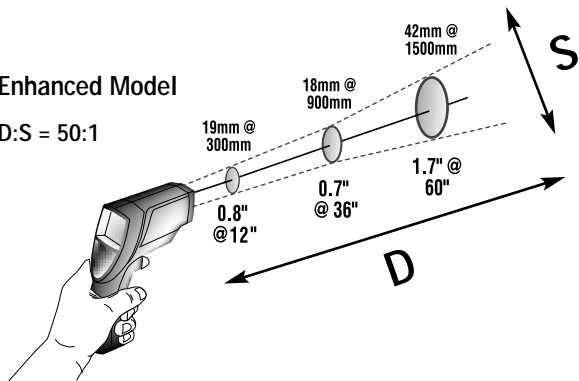

MODE button Functions

Your infrared thermometer measures Maximum (MAX), Minimum (MIN), Differential (DIF)*, and Average (AVG)** temperatures each time you take a reading. This data is stored and can be recalled with the MODE button (3) until a new measurement is taken. (See "Hold and Recall" for information on how to recall stored data.). When the trigger is pulled again, the unit will begin measuring in the last mode selected.

Pressing the MODE button also allows you to access the High Alarm (HAL), Low Alarm (LAL), Emissivity (EMS), Probe temperature (PRB – only available when the probe is connected), and Data logger (LOG). Each time you press MODE, you advance through the mode cycle. The diagram shows the sequence of functions in the Mode cycle.

Note: PRB (probe) is only available in the MODE loop when the contact probe is connected to the unit.

*DIF shows the difference between the maximum and minimum temperatures measured

**AVG shows the average temperature reading for each time the trigger is pulled or the unit is locked on

Selecting a Function

To Select the MAX, MIN, DIF, or AVG mode, pull the trigger. While holding the trigger, press the MODE button (3) until the appropriate code appears in the lower left corner of the display (E). Each time you press MODE, you advance through the MODE cycle. The MODE cycle is shown above.

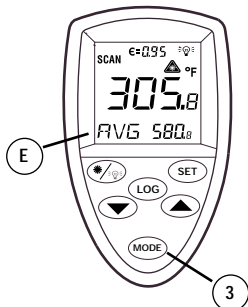
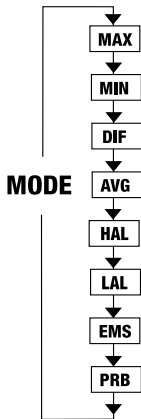

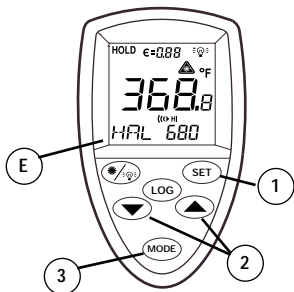

Setting the High Alarm, Low Alarm, and Emissivity

To set values for the High Alarm (HAL), Low Alarm (LAL), and emissivity, pull the trigger or press the MODE button (3) to activate the display. Press the MODE button until the appropriate code appears in the lower left corner of the display (E). Use the up and down keys (2) to adjust the desired values. To activate the alarms, press SET (1). To deactivate the alarms, press SET again.



Using a Probe (PRB)

Connect the probe to the input on the side of the unit (as shown). PRB automatically appears in the lower left corner of the display (E, below). The probe temperature is shown in the lower right part of the display. The current infrared temperature continues to show in the center of the display (F). While the probe is connected, you may still cycle through the mode functions by pressing MODE (3).

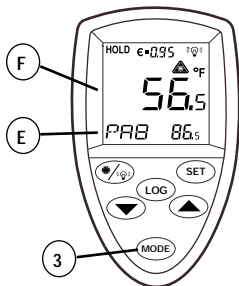

Note: PRB is only available in the MODE loop when a probe is connected to the unit; the probe temperature will not activate the high alarm or low alarm.

Hold and Recall

The unit's display will remain activated (HOLD) for seven seconds after the trigger is released (unless the unit is locked on); HOLD will appear in the upper left corner of the display (H). During HOLD, or after the unit shuts off, you can recall stored values by pressing the MODE button (3) without pulling the trigger. Each time you press the MODE button, you advance through the Mode Cycle. When the trigger is pulled again, the unit will begin measuring in the last Mode selected.

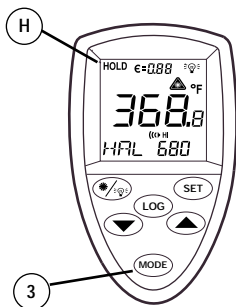

Storing Data

Your thermometer is capable of storing up to 12 data locations. The infrared temperature, temperature scale (°C or °F), and emissivity are also stored.

Infrared

To store data from an infrared reading, pull the trigger. While holding the trigger, press the MODE button (3) until LOG appears in the lower left corner of the display (E); a log location number will be shown below LOG. If no temperature has been recorded in the shown LOG location, 3 dashes will appear in the lower right corner. Aim the unit at the target area you want to record, and press the LOG button (5). You will hear a tone to confirm that the location temperature has been recorded. The recorded temperature will appear in the lower right corner (D). To select another log location, press the up and down keys (2).

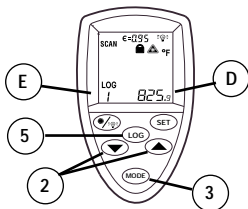
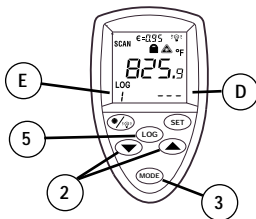

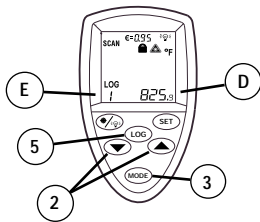

Recalling Data

To recall stored data after the unit shuts off, press the MODE button (3) until LOG appears in the lower left corner (E). A LOG location number will be shown below LOG, and the stored temperature for that location will be shown in the lower right corner of the display (D). To move to another LOG location, press the Up and Down keys (2).

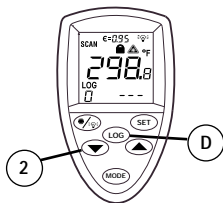

Log Clear Function

The "LOG clear" function allows you to quickly clear all logged data points. This function can only be used when the unit is in LOG mode. It can be used when the user has any number of log locations stored.

CAUTION: You should only use the LOG clear function if you want to clear all at once the Log location data that is stored in the unit's memory.

The "LOG clear" function works as follows:

1) While in LOG mode, press the trigger, and then press the "down" arrow button (2) until you reach LOG location "0".

NOTE: This can only be done when the trigger is pulled. LOG location "0" cannot be accessed, by using the "up" arrow button.

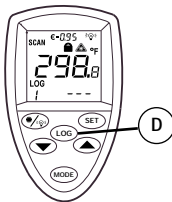

2) When LOG location "0" shows in the lower left-hand corner of the display, press the LOG button (D). Three tones will sound, and the LOG location will automatically change to "1", signifying that all data locations have been cleared.

Reminders

- Not recommended for use in measuring shiny or polished metal surfaces (stainless steel, aluminum, etc.). See "Emissivity" for measuring these surfaces.
- The unit cannot measure through transparent surfaces such as glass or plastic. It will measure the surface temperature of these materials instead.
- Steam, dust, smoke, or other particles can prevent accurate measurement by obstructing the unit's optics.

Maintenance

Cleaning the lens: Blow off loose particles using clean compressed air. Gently brush remaining debris away with a camel's hair brush. Carefully wipe the surface with a moist cotton swab. The swab may be moistened with water. NOTE: DO NOT use solvents to clean the glass lens.

Cleaning the housing: Use soap and water on a damp sponge or soft cloth. NOTE: DO NOT submerge the unit in water.

Troubleshooting

Code	Problem	Action
--- (on display)	Target temperature is over or under range	Select target within specifications
Battery icon appears 	Low battery	Check and/or replace battery
Blank display	Possible dead battery	Check and/or replace battery
Laser doesn't work	(1) Low or dead battery (2) Ambient temperature above 40°C (104°F)	(1) Replace battery (2) Use in area with lower ambient temperature
ERR	Possible damage by EMF	Contact your distributor



CE Certification

This instrument conforms to the following standards:

- EN50081-1:1992, Electromagnetic Emissions
- EN50082-1:1997, Electromagnetic Susceptibility

Tests were conducted using a frequency range of 80-1000 MHz with the instrument in three orientations. The average error for the three orientations is $\pm 1.4^{\circ}\text{C}$ ($\pm 2.5^{\circ}\text{F}$) at 3 V/m throughout the spectrum. However, between 162 MHz and 792 MHz at 3 V/m, the instrument may not meet its stated accuracy.