



DELUXE FREESTANDING TWO-KAYAK STORAGE RACK

SKU: RGFSKR
User Guide



DELUXE FREESTANDING TWO-KAYAK STORAGE RACK

SKU: RGFSKR
User Guide

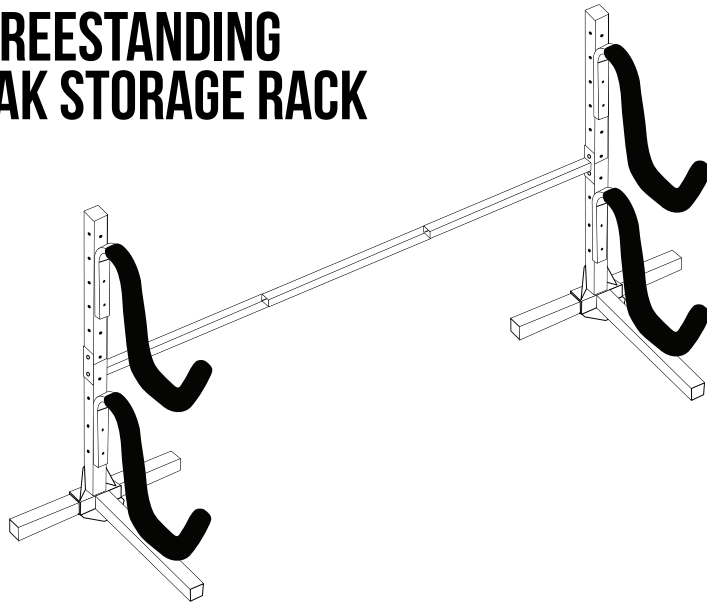

Thank you for purchasing the RaxGo™ Deluxe Freestanding Two-Kayak Storage Rack. This User Guide is intended to provide you with guidelines to ensure that operation of this product is safe and does not pose risk to the user. Any use that does not conform to the guidelines described in this User Guide may void the limited warranty.

Please read all directions before using the product and retain this guide for reference. This product is intended for household use only. It is not intended for commercial use.

This product is covered by a limited one-year warranty. Coverage is subject to limits and exclusions. See warranty for details.

SAFETY PRECAUTIONS

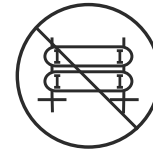

This rack is intended for use with kayaks only. Do not attempt to mount other objects/persons on the rack.



The total capacity of this rack is a maximum of two (2) kayaks permitted, totaling 175 lbs. (79.4 kg). Do not exceed the weight limit on the kayak rack, or else you could damage your kayak and/or the rack.



Do not attempt to modify the rack or perform repairs on your own. If the rack is faulty or becomes damaged, you should take it to an authorized serviceperson for repairs.



Do not attempt to suspend more than two (2) kayaks at a time from this mount. Overloading the mount could result in damage to the mount and/or your kayaks.





Children should not be permitted to assemble or operate this mount.



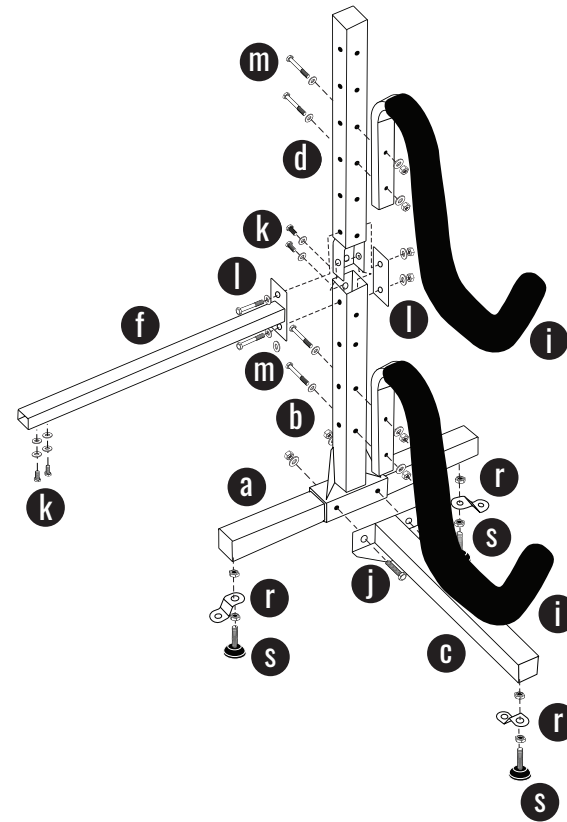
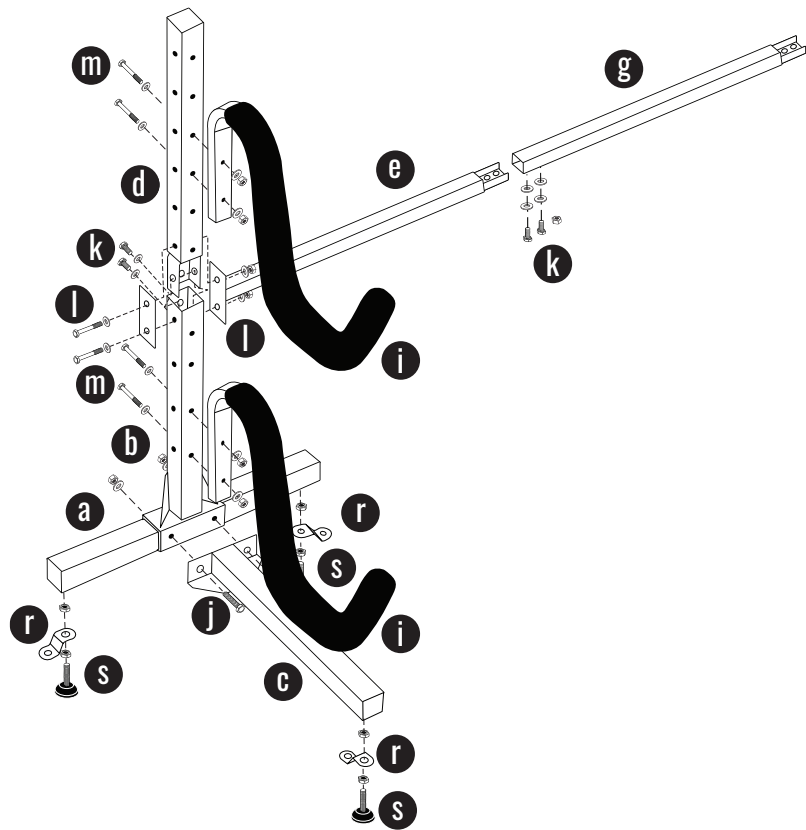

Always make sure this mount is installed on a stable, flat surface in an area that is free from heavy shocks or vibrations, to avoid the risk of the mount falling over and causing injuries and/or damage.

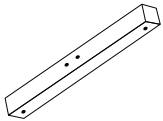
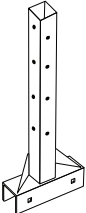
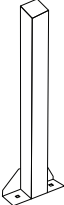
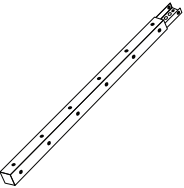
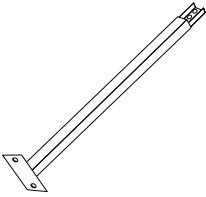
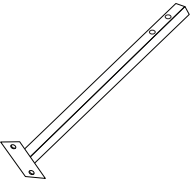
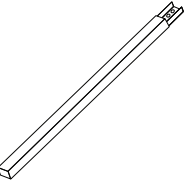
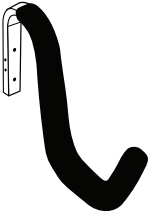
PARTS LIST

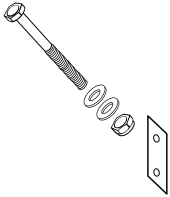

PARTS LIST			
			
Bases	2 PCS	Base Posts	2 PCS
			
Posts	2 PCS	Cross Bar End (Male)	1 PC
		Cross Bar End (Female)	1 PC
			
Central Cross Bar	1 PC	Arms	4 PCS
		Carriage Bolts (3")	4 PCS

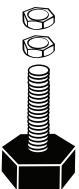
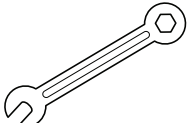
PARTS LIST			
			
$\frac{3}{4}$ " Hex Bolts	8 PCS	2 $\frac{3}{4}$ " Hex Bolts & Plate	5 PCS
		3 $\frac{1}{2}$ " Hex Bolts	8 PCS
			
Anchor Brackets	6 PCS	Leveling Feet	6 PCS
		Wrenches	2 PCS
<p>NOTE: Washers and lock nuts come connected to the bolts they correspond to in the packaging.</p>		<p>NOTE: For your convenience, part labels are marked on the blister packaging to help you match the part to the corresponding diagram.</p>	

ASSEMBLY INSTRUCTIONS

1. Locate parts a, b, and c. Make sure the welded nuts on the bottom of the bases (a) are facing down. Fit the base post (b) over the top of the base (a) and align the base leg (c) with the two (2) holes on the side of base (a) and on the bottom of base leg (b). Use the carriage bolts (j) with washers and lock nuts to connect the base leg (c) to the base (a) as shown in the parts diagram below. Repeat this process for the second set of a, b, and c parts.

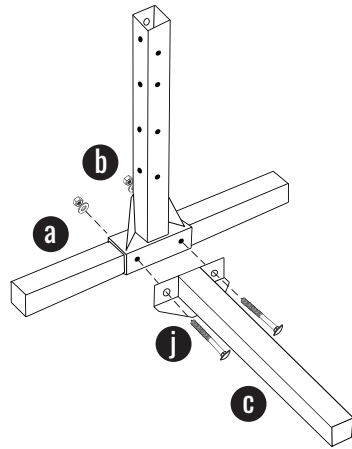

2. Attach the leveling feet (s) by placing two (2) hex nuts (that come with each leveling foot) and an anchor bracket (r) on each one. Make sure the anchor bracket has one nut on both sides of it. Lean the assembled base to one side and attach the leveling feet (s) to the welded nuts on the underside of the base (a) and base leg (c). Repeat this process on the second assembled base.

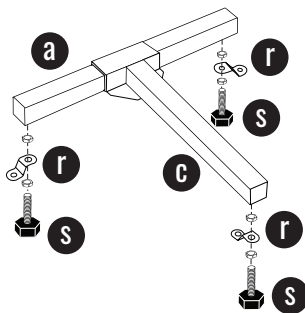

3. Insert the post (d) into the base post (b) making sure the empty side of the post (d) faces the base leg (c). Using two (2) $\frac{3}{4}$ " hex bolts (k), each with a locking washer and a thick washer, attach the post (d) to the base post (b), making sure the welded nuts are facing the rear and are aligned with the corresponding holes. Repeat this process on the second assembled base post.

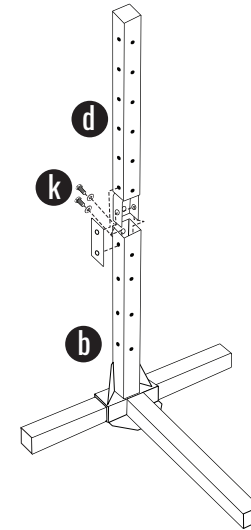

4. Place the cross bar plate (l) on one side of the post (d) and the base post (b) and place the cross bar end (male) (e) on the opposite side. Use two (2) $2\frac{3}{4}$ " hex bolts (l) to attach the cross bar plate and the cross bar end (male) to the holes where the post and base post connect. Then, connect the central cross bar (g) to the cross bar end (male) using two (2) $\frac{3}{4}$ " hex bolts (k). Finally, connect the cross bar end (female) (f) to the central cross bar using two more (2) $\frac{3}{4}$ " hex bolts (k).

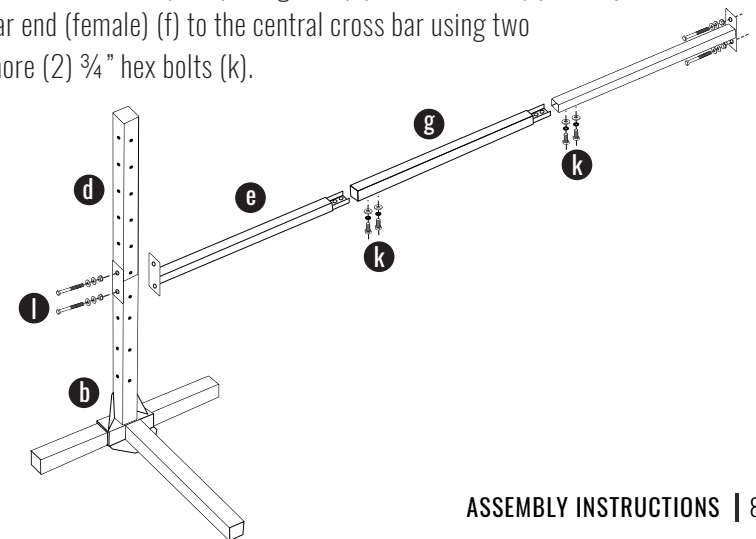

5. Attach the assembled cross bar from step 4 to the second assembled base from steps 1-3, using the second cross bar plate (l), and two (2) of the 2 3/4" hex bolts (t), with two (2) washer and a lock nut on each bolt to attach the plate to the frame.

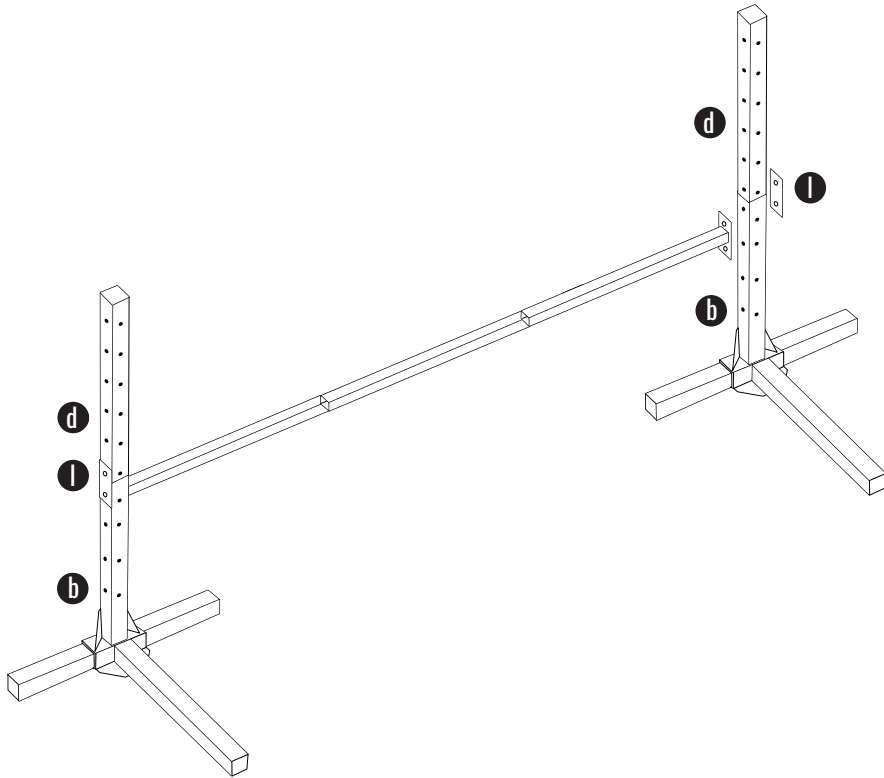

6. Use two (2) 3 1/2" hex bolts (m), with two (2) washers and a lock nut on each, to attach the rack arms (i) to the frame. Attach the first arm to the lowest two holes possible, and the second arm in the highest two holes possible. Repeat on the other side. (You may find it helpful during this part of the process to use one wrench to hold the bolt in place and use a second wrench to turn the lock nut).

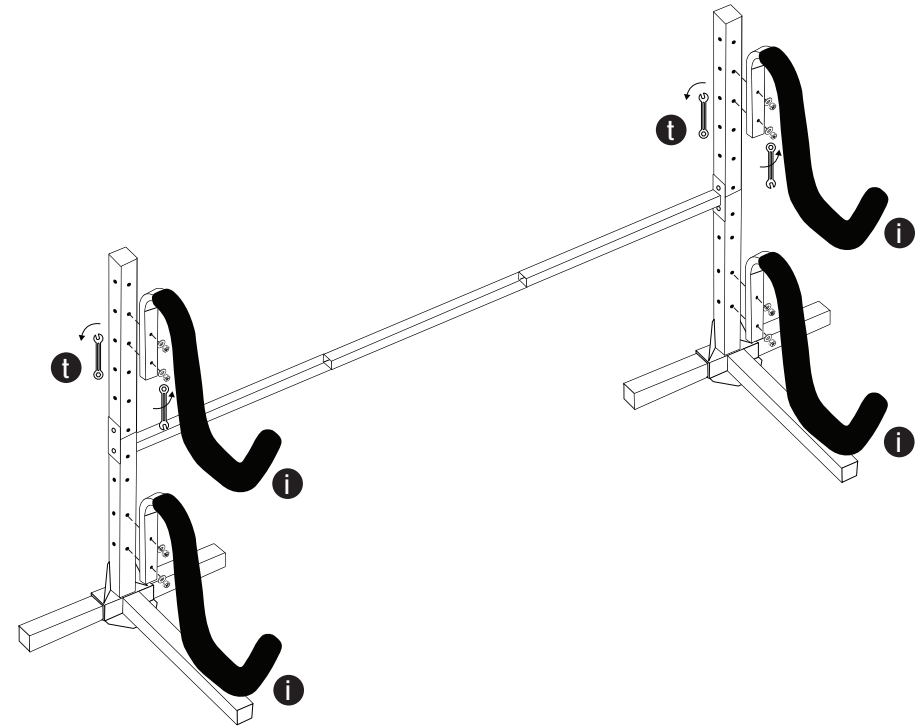

7. The kayak rack should be fully assembled. If possible, drill a bolt down into the floor with the anchor brackets (r) to stabilize the unit in a permanent position, preventing it from tipping over. If not, make sure that the weight is always evenly distributed, and if only storing one kayak, store it on the lower rack.

SPECIFICATIONS

Assembled Dimensions: 52" H x 94" W x 26" D (132.1 x 238.8 x 66 cm)

LIMITED WARRANTY ON RAXGO™ DELUXE FREESTANDING TWO-KAYAK STORAGE RACK

THIS LIMITED WARRANTY GIVES YOU SPECIFIC LEGAL RIGHTS AND YOU MAY ALSO HAVE OTHER RIGHTS, WHICH VARY FROM STATE TO STATE.

WE WARRANT THAT DURING THE WARRANTY PERIOD, THE PRODUCT WILL BE FREE FROM DEFECTS IN MATERIALS AND WORKMANSHIP.

LIMITATION OF LIABILITY

TO THE EXTENT NOT PROHIBITED BY LAW, THIS WARRANTY IS EXCLUSIVE AND IN LIEU OF ALL OTHER WARRANTIES, ORAL, WRITTEN, STATUTORY, EXPRESS OR IMPLIED. EXCEPT FOR THE EXPRESS WARRANTIES CONTAINED IN THIS LIMITED WARRANTY STATEMENT AND TO THE EXTENT NOT PROHIBITED BY LAW, WE DISCLAIM ALL OTHER WARRANTIES, EXPRESSED OR IMPLIED, STATUTORY OR OTHERWISE, INCLUDING WITHOUT LIMITATION, THE WARRANTIES OF MERCHANTABILITY AND FITNESS FOR A PARTICULAR PURPOSE. SOME STATES DO NOT ALLOW DISCLAIMERS OF IMPLIED WARRANTIES, SO THIS DISCLAIMER MAY NOT APPLY TO YOU. TO THE EXTENT SUCH WARRANTIES CANNOT BE DISCLAIMED UNDER THE LAWS OF YOUR JURISDICTION, WE LIMIT THE DURATION AND REMEDIES OF SUCH WARRANTIES TO THE DURATION OF THIS EXPRESS LIMITED WARRANTY.

OUR RESPONSIBILITY FOR DEFECTIVE GOODS IS LIMITED TO REPAIR, REPLACEMENT OR REFUND AS DESCRIBED BELOW IN THIS WARRANTY STATEMENT.

WHO MAY USE THIS WARRANTY? C&A MARKETING, INC. LOCATED AT 114 TIVED LANE EAST, EDISON, NJ (“**WE**”) EXTEND THIS LIMITED WARRANTY ONLY TO THE CONSUMER WHO ORIGINALLY PURCHASED THE PRODUCT (“**YOU**”). IT DOES NOT EXTEND TO ANY SUBSEQUENT OWNER OR OTHER TRANSFEREE OF THE PRODUCT.

WHAT DOES THIS WARRANTY COVER? THIS LIMITED WARRANTY COVERS DEFECTS IN MATERIALS AND WORKMANSHIP OF THE RAXGO DELUXE FREESTANDING TWO-KAYAK STORAGE RACK (THE “**PRODUCT**”) FOR THE WARRANTY PERIOD AS DEFINED BELOW.

WHAT DOES THIS WARRANTY NOT COVER? THIS LIMITED WARRANTY DOES NOT COVER ANY DAMAGE DUE TO: (A) TRANSPORTATION; (B) STORAGE; (C) IMPROPER USE; (D) FAILURE TO FOLLOW THE PRODUCT INSTRUCTIONS OR TO PERFORM ANY PREVENTIVE MAINTENANCE; (E) MODIFICATIONS; (F) UNAUTHORIZED REPAIR; (G) NORMAL WEAR AND TEAR; OR (H) EXTERNAL CAUSES SUCH AS ACCIDENTS, ABUSE, OR OTHER ACTIONS OR EVENTS BEYOND OUR REASONABLE CONTROL.

WHAT IS THE PERIOD OF COVERAGE? THIS LIMITED WARRANTY STARTS ON THE DATE OF YOUR PURCHASE AND LASTS FOR ONE YEAR (THE “**WARRANTY PERIOD**”). THE WARRANTY PERIOD IS NOT EXTENDED IF WE REPAIR OR REPLACE THE PRODUCT. WE MAY CHANGE THE AVAILABILITY OF THIS LIMITED WARRANTY AT OUR DISCRETION, BUT ANY CHANGES WILL NOT BE RETROACTIVE.

WHAT ARE YOUR REMEDIES UNDER THIS WARRANTY? WITH RESPECT TO ANY DEFECTIVE PRODUCT DURING THE WARRANTY PERIOD, WE WILL, AT OUR SOLE DISCRETION, EITHER: (A) REPAIR OR REPLACE SUCH PRODUCT (OR THE DEFECTIVE PART) FREE OF CHARGE OR (B) REFUND THE PURCHASE PRICE OF SUCH PRODUCT IF AN EXCHANGE UNIT CANNOT BE PROVIDED.

HOW DO YOU OBTAIN WARRANTY SERVICE? TO OBTAIN WARRANTY SERVICE, YOU MUST CONTACT US AT 1-833-722-0121 OR BY EMAIL AT INFO@SUPPORTCBP.COM DURING THE WARRANTY PERIOD TO OBTAIN A DEFECTIVE MERCHANDISE AUTHORIZATION (“**DMA**”) NUMBER. NO WARRANTY SERVICE WILL BE PROVIDED WITHOUT A DMA NUMBER AND RETURN SHIPPING COSTS TO OUR FACILITIES SHALL BE ASSUMED BY YOU, THE PURCHASER. SHIPPING COSTS OF THE REPLACEMENT UNIT TO YOU SHALL BE ASSUMED BY US.



NEED ASSISTANCE? WE WANT TO HEAR FROM YOU!

raxgo.com
support@raxgo.com
1-833-722-0121

RAXGO is a trademark of C&A IP Holdings, LLC in the US.

All other products, brand names, company names, and logos are trademarks of their respective owners, used merely to identify their respective products, and are not meant to connote any sponsorship, endorsement, or approval.

Distributed by C&A Marketing, Inc., 114 Tived Lane East, Edison, NJ 08837. Made in China.

© 2020. C&A IP Holdings, LLC. All Rights Reserved.