

Service options, parts availability, and response times may vary and may change at any time. In accordance with applicable law, the Company may require that you furnish additional documents and/or comply with registration requirements before receiving warranty service. Please contact our customer service for details on obtaining warranty service:

Email: support@raxgo.com
Phone: 833-722-0121

Shipping expenses to the Company's Return Facility are not covered by this warranty and must be paid by the consumer. The consumer likewise bears all risk of loss or further damage to the Product until delivery to said facility.

EXCLUSIONS AND LIMITATIONS The Company warrants the Product against defects in materials and workmanship under normal use for a period of **ONE (1) YEAR** from the date of retail purchase by the original end-user purchaser ("Warranty Period"). If a hardware defect arises and a valid claim is received within the Warranty Period, the Company, at its sole option and to the extent permitted by law, will either (1) repair the Product defect at no charge, using new or refurbished replacement parts, (2) exchange the Product with a Product that is new or which has been manufactured from new or serviceable used parts and is at least functionally equivalent to the original device, or (3) refund the purchase price of the Product.

A replacement Product or part thereof shall enjoy the warranty of the original Product for the remainder of the Warranty Period, or ninety (90) days from the date of replacement or repair, whichever provides you longer protection. When a Product or part is exchanged, any replacement item becomes your property, while the replaced item becomes the Company's property. Refunds can only be given if the original Product is returned.

This Warranty does not apply to:

- (a) Any non-RaxGo™ Wall-Mounted Storage Rack product, hardware or software, even if packaged or sold with the Product;
- (b) Damage caused by use with non-RaxGo™ Wall-Mounted Storage Rack products;
- (c) Damage caused by accident, abuse, misuse, flood, fire, earthquake, or other external causes;
- (d) Damage caused by operating the Product outside the permitted or intended uses described by the Company;
- (e) Damage caused by third party services;
- (f) A Product or part that has been modified to alter functionality or capability without the written permission of the Company;
- (g) Consumable parts, such as batteries, fuses, and bulbs;
- (h) Cosmetic damage; or
- (i) If any RaxGo™ Wall-Mounted Storage Rack serial number has been removed or defaced.

This Warranty is valid only in the country where the consumer purchased the Product, and only applies to Products purchased and serviced in that country. The Company does not warrant that the operation of the Product will be uninterrupted or error-free. The Company is not responsible for damage arising from your failure to follow instructions relating to its use.

NOTWITHSTANDING ANYTHING TO THE CONTRARY AND TO THE MAXIMUM EXTENT PERMITTED BY APPLICABLE LAW, THE COMPANY PROVIDES THE PRODUCT "AS-IS" AND "AS-AVAILABLE" FOR YOUR CONVENIENCE AND THE COMPANY AND ITS LICENSORS AND SUPPLIERS EXPRESSLY DISCLAIM ALL WARRANTIES AND CONDITIONS, WHETHER EXPRESSED, IMPLIED, OR STATUTORY, INCLUDING THE WARRANTIES OF MERCHANTABILITY, FITNESS FOR A PARTICULAR PURPOSE, TITLE, QUIET ENJOYMENT, ACCURACY, AND NON-INFRINGEMENT OF THIRD-PARTY RIGHTS. THE COMPANY DOES NOT GUARANTEE ANY SPECIFIC RESULTS FROM THE USE OF THE PRODUCT, OR THAT THE COMPANY WILL CONTINUE TO OFFER OR MAKE AVAILABLE THE PRODUCT FOR ANY PARTICULAR LENGTH OF TIME. THE COMPANY FURTHER DISCLAIMS ALL WARRANTIES AFTER THE EXPRESS WARRANTY PERIOD STATED ABOVE.

YOU USE THE PRODUCT AT YOUR OWN DISCRETION AND RISK. YOU WILL BE SOLELY RESPONSIBLE FOR (AND THE COMPANY DISCLAIMS) ANY AND ALL LOSS, LIABILITY, OR DAMAGES RESULTING FROM YOUR USE OF THE PRODUCT.

NO ADVICE OR INFORMATION, WHETHER ORAL OR WRITTEN, OBTAINED BY YOU

FROM THE COMPANY OR THROUGH ITS AUTHORIZED SERVICE PROVIDERS SHALL CREATE ANY WARRANTY.

IN NO EVENT WILL THE COMPANY'S TOTAL CUMULATIVE LIABILITY ARISING FROM OR RELATED TO THE PRODUCT, WHETHER IN CONTRACT OR TORT OR OTHERWISE EXCEED THE FEES ACTUALLY PAID BY YOU TO THE COMPANY OR ANY OF ITS AUTHORIZED RESELLERS FOR THE PRODUCT AT ISSUE IN THE LAST YEAR FROM YOUR PURCHASE. THIS LIMITATION IS CUMULATIVE AND WILL NOT BE INCREASED BY THE EXISTENCE OF MORE THAN ONE INCIDENT OR CLAIM. THE COMPANY DISCLAIMS ALL LIABILITY OF ANY KIND OF ITS LICENSORS AND SUPPLIERS. IN NO EVENT WILL THE COMPANY OR ITS LICENSORS, MANUFACTURERS, AND SUPPLIERS BE LIABLE FOR ANY INCIDENTAL, DIRECT, INDIRECT, SPECIAL, PUNITIVE, OR CONSEQUENTIAL DAMAGES (SUCH AS, BUT NOT LIMITED TO, DAMAGES FOR LOSS OF PROFITS, BUSINESS, SAVINGS, DATA, OR RECORDS) CAUSED BY THE USE, MISUSE, OR INABILITY TO USE THE PRODUCT.

Nothing in these terms shall attempt to exclude liability that cannot be excluded under applicable law. Some countries, states, or provinces do not allow the exclusion or limitation of incidental or consequential damages or allow limitations on warranties, so certain limitations or exclusions may not apply to you. This warranty gives you specific legal rights, and you may have other rights that vary from state to state or province to province. Contact your authorized retailer to determine if another warranty applies.

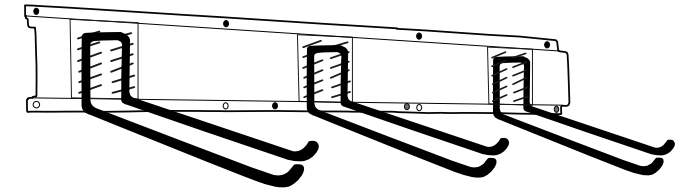

**NEED ASSISTANCE?
WE WANT TO HEAR FROM YOU!**

✉ support@raxgo.com

☎ 1-833-722-0121

RAXGO is a trademark of C&A IP Holdings, LLC in the US.

All other products, brand names, company names, and logos are trademarks of their respective owners, used merely to identify their respective products, and are not meant to connote any sponsorship, endorsement, or approval.

Distributed by C&A Marketing, Inc., 114 Tived Lane East, Edison, NJ 08837.

Made in China.

© 2020. C&A IP Holdings, LLC. All Rights Reserved.

**WALL- MOUNTED
STORAGE RACK**

USER GUIDE

RAXWMCR

Thank you for purchasing the **RaxGo™ Wall-Mounted Storage Rack**. This User Guide is intended to provide you with guidelines to ensure that operation of this product is safe and does not pose risk to the user. Any use that does not conform to the guidelines described in this User Guide may void the limited warranty.

Please read all directions before using the product and retain this guide for reference. This product is intended for household use only. It is not intended for commercial use.

This product is covered by a limited one-year warranty. Coverage is subject to limits and exclusions. See warranty for details.

1. PACKAGE CONTENTS

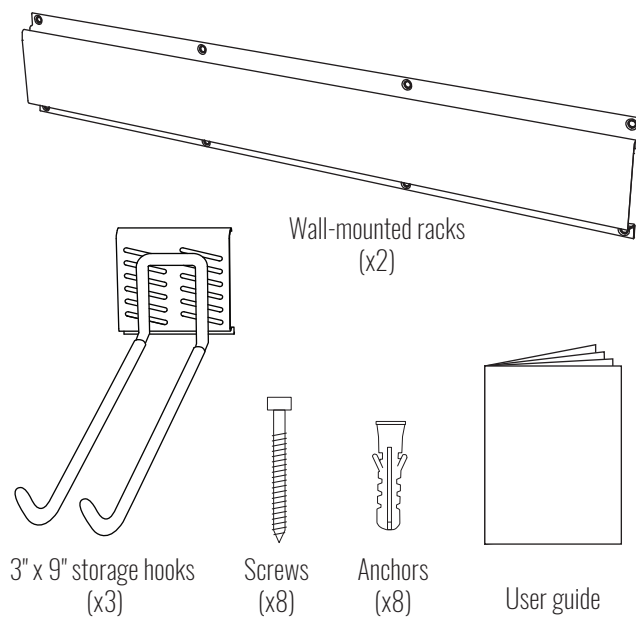

2. SAFETY PRECAUTIONS

- ⚠ WARNING: CHOKING HAZARD – Small parts.** This product contains small parts and is not suitable for children under 3 years old.
- Remove all packaging before using this device. Please keep all packaging materials out of reach of children and pets.
- Properly dispose of all packing materials immediately after unpacking product, as the bags used for packaging could present a suffocation or choking hazard.
- Read all instructions carefully before attempting to operate this device. Improper usage or installation could result in injury or a reduction in efficacy.
- Do not exceed 132.3 lbs. (60 kg) weight limit. Exceeding its weight capacity could result in damage or injury.

- Do not let children play on or around the rack as this can cause accidents, injuries, or damage the rack.
- This product is designed for indoor use only.
- Make sure no people or pets are near or under the rack when loading equipment on or off.

A Note on Anchors

The anchors included with this product are only intended for use with concrete and/or brick. While standard anchors intended for use with concrete and/or brick walls are included with this storage rack, it remains the responsibility of the person installing the storage rack to determine which anchor type should be used for each specific installation and/or type of substrate. Please ensure that appropriate pullout tests are performed prior to installation.

If you are unsure about what type of mounting hardware you should use, please ask a professional for assistance.

In no event shall RaxGo™ be liable for any direct, special, punitive, exemplary, indirect, or consequential damages resulting from improper installation, misuse, and/or use of the product beyond its limitations and/or intended purpose. This includes, without limitations, overloading of the product and/or use of the product under extreme or abnormal conditions, either intentionally or as a result of user error.

Recommend Tools:

- Drill
- Drill bit
- Pencil
- Level

3. INSTALLATION INSTRUCTIONS

- Locate studs in the wall if applicable. Check to make sure the location you want to install the rack doesn't damage any electrical wires, gas pipes, water pipes, or other items within your wall.
- Using a level, mark a horizontal line on the wall. The line you make will indicate the position of the bottom of the rack.
- Position the rack with the bottom against the line so that the top is facing up, as shown (A). Then, mark the screw holes.

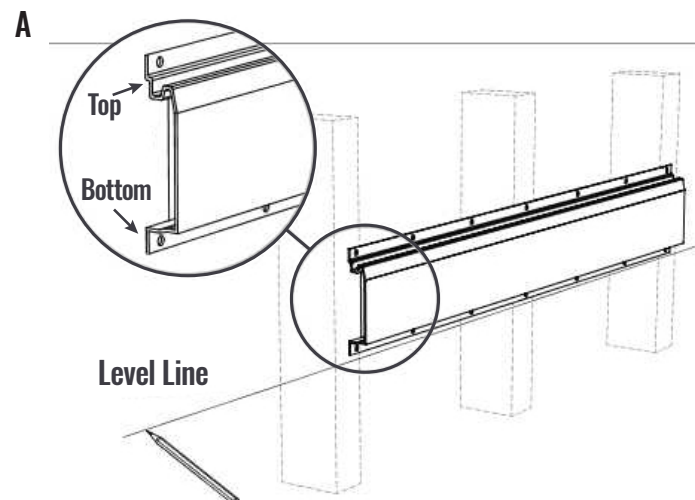

- Drill the needed holes into the marked areas. Remember to use a drill bit about ½ the size of the screws (B).

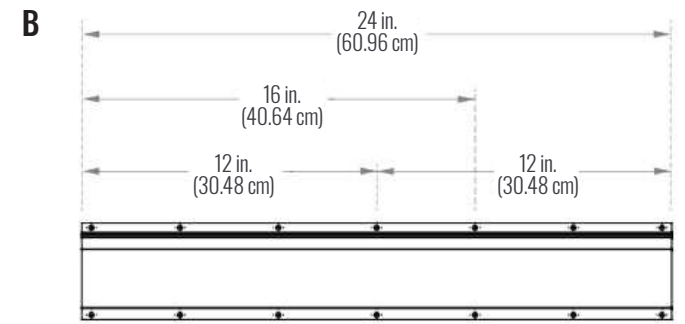

- Position the rack on the marked line and line up the drilled holes with the holes of the rack. Then, insert the anchors into the holes.
- Place screws into the anchors and use the drill to tighten the screws into the wall. Make sure the rack is secured firmly into the wall.
- Mount the storage hooks on the rack by sliding them on from either end of the rack (C).



4. SPECIFICATIONS

Weight capacity: 132.3 lbs. (60 kg)

Weight capacity per storage hook: 44.1 lbs. (20 kg)

5. WARRANTY INFORMATION

LIMITED WARRANTY ON RAXGO™ WALL-MOUNTED STORAGE RACK

This **RaxGo™ Wall-Mounted Storage Rack** ("Product"), including any accessories included in the original packaging, as supplied and distributed new by an authorized retailer is warranted by C&A Marketing, Inc. (the "Company") to the original consumer purchaser only, against certain defects in material and workmanship ("Warranty") as follows:

To receive Warranty service, the original consumer purchaser must contact the Company or its authorized service provider for problem determination and service procedures. Proof of purchase in the form of a bill of sale or receipted invoice, evidencing that the Product is within the applicable Warranty period(s), MUST be presented to the Company or its authorized service provider in order to obtain the requested service.