

## REPLACEMENT PARTS

Replacement Part:	Part Number:
Locking Caster	W54005-1
Standard Caster	W54005-2
Nut & Bolt Hardware Kit	W54005-HW

# 3-SHELF MECHANICS SHOP CART

Stock Number W54006

## OWNER'S MANUAL



### LIMITED WARRANTY

PERFORMANCE TOOL extends only the following warranties, and only to original retail purchasers. These warranties give specific legal rights. Except where prohibited by local law, the law of the State of Washington governs all warranties and all exclusions and limitations of warranties and remedies. There may be other rights which vary from state to state.

PERFORMANCE TOOL warrants the product to be free from defects in materials and workmanship under normal use and service. A defective product may be returned for a free replacement within 90 days from the date of purchase, provided that product is returned to place of purchase immediately after discovery of defect. After 90 days and up to 1 year from date of purchase, PERFORMANCE TOOL will replace at no charge any parts which our examination shall disclose to be defective and under warranty.

These warranties exclude blades, bits, punches, dies, bulbs, fuses, and other consumables which must be replaced under normal use and service. These warranties shall not apply to any product or part which is used for a purpose for which it is not designed, or which has been repaired or altered in any way so as to affect adversely its performance or reliability, nor shall these warranties apply to any product or part which has been subject to misuse, neglect, accident or wear and tear incident to normal use and service.

PERFORMANCE TOOL does not authorize any other person to make any warranty or to assume any liability in connection with its products.

Except for warranties of title and the limited express warranties set forth above, PERFORMANCE TOOL makes no express or implied warranties of any kind with respect to its products. In particular, PERFORMANCE TOOL makes no implied warranty of merchantability and no implied warranty of fitness for any particular purpose, except that for goods purchased primarily for personal, family or household use and not for commercial or business use, PERFORMANCE TOOL makes an implied warranty of merchantability (and, if otherwise applicable, an implied warranty of fitness for a particular purpose), but only for the particular qualities or characteristics, and for the duration, expressly warranted above. The laws on limitation of implied warranties may differ from state to state, so the above limitations may not apply in all cases.

PERFORMANCE TOOL shall not be liable for consequential, incidental or special damages resulting from or in any manner related to any product, or to the design, use, or any inability to use the product. The sole and exclusive remedy for a defective product or part shall be the repair, or replacement thereof as provided above. The laws on limitation of remedies or on consequential, incidental or special damages may vary from state to state, so the above limitations may not apply in all cases.

**FOR YOUR SAFETY,**  
please read these instructions carefully and retain them for future use.

**Performance  
Tool**

## PARTS LIST

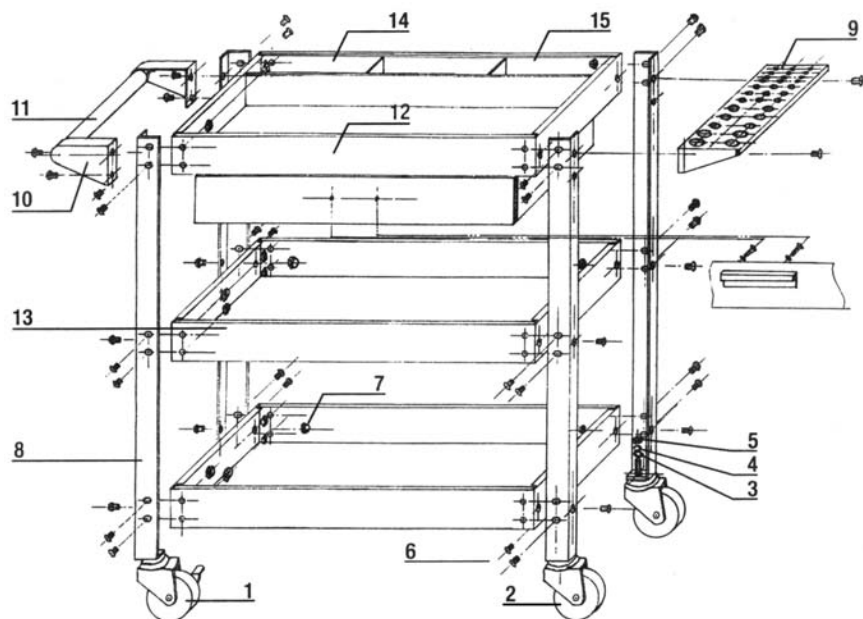

NO.	DESCRIPTION	QTY
1	LOCKING CASTERS	2
2	STANDARD CASTERS	2
3	CASTER FLAT WASHERS	4
4	CASTER LOCK WASHERS	4
5	19mm CASTER NUTS	4
6	10mm SLOTTED MACHINE SCREWS	38
7	10mm ACORN NUTS	38
8	UPRIGHT BARS	4
9	TOOL TRAY	1
10	HANDLE BRACKETS	2
11	HANDLE BAR	1
12	SHELF WITH STORAGE DRAWER	1
13	PLAIN SHELF	2
14	LARGE FOAM SHELF PADS	3
15	SMALL FOAM BIN PADS	3

## TOOLS REUIRED

- 19mm Socket or Adjustable Wrench
- 1/4" Slotted Screwdriver
- 10mm Socket, Nut Driver or Combination Wrench
- OPTIONAL: Thread Locking Compound

## ASSEMBLY INSTRUCTIONS

1. Ensure there are no missing parts. Refer to part number W54006.
2. Note that each upright has an open end and an end with a drilled plate for mounting a caster. Ensure that the end with the drilled plate is on the bottom before beginning assembly.
3. Lay a single upright on a flat surface. Using the 10mm slotted screws and acorn nuts, attach all three shelves to the upright. Ensure that the shelf with storage drawer is the highest shelf (farthest from the bottom of the upright).
4. Attach a second upright directly across from the first upright, then carefully flip the unit over. Install the third and fourth uprights, ensuring all nuts are securely tightened. The use of a thread-locking compound is recommended to prevent fasteners from loosening with use.
5. Install tool tray on either side of top shelf, as desired.
6. Install a single handle bracket on the side opposite the tool tray. Slide handlebar in and install second handle bracket.
7. Install casters and foam pads.

### WARNING!

- MAXIMUM CAPACITY OF TOOL CART IS 200 LBS. DO NOT OVERLOAD.
- READ, STUDY, AND UNDERSTAND ALL WARNINGS AND OPERATING INSTRUCTIONS PRIOR TO USE.
- FAILURE TO HEED THESE WARNINGS MAY RESULT IN PERSONAL INJURY AND/OR PROPERTY DAMAGE.
- WHEN POSITIONING TABLE NEXT TO PAINTED OR VALUABLE WORK AREAS, INSURE TABLE LOCKING DEVICE IS SECURE AND SURFACES HAVE PROTECTIVE, NON-SCRATCH COVERS.
- NO ALTERATIONS SHALL BE MADE TO THIS PRODUCT.
- DO NOT SIT OR STAND ON CART.