

# ***2 Shelf Utility Cart with Locking Drawer***

Stock Number W54004

## **OWNERS MANUAL**

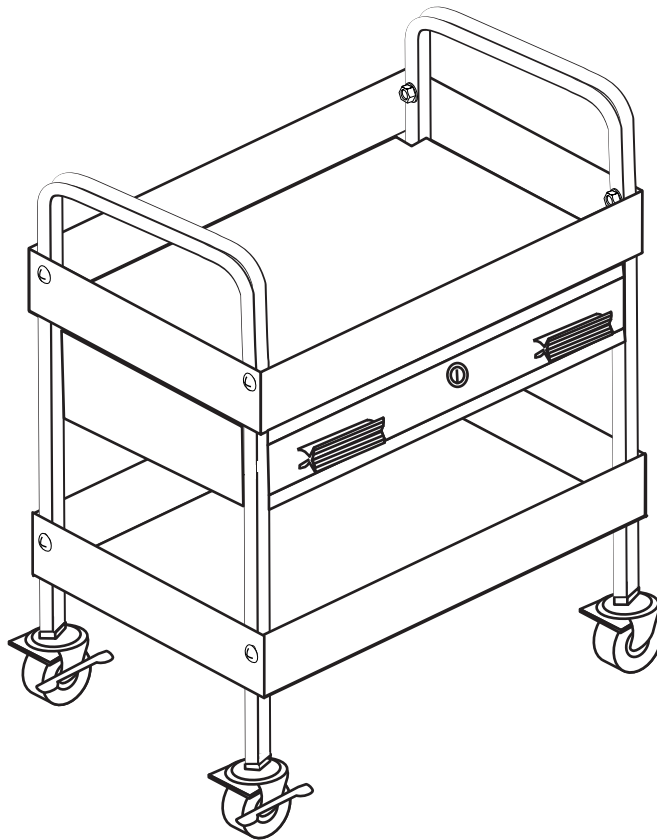

Please read these instructions carefully and retain them for future use.



### **LIMITED WARRANTY**

This warranty gives you specific legal rights, and you may also have other rights which vary from state to state. WILMAR warrants this product to be free from defects in materials and workmanship under normal use and service. You may return this product for a free replacement within 90 days from the date of purchase, provided that product is returned immediately to place of purchase. After 90 days and up to 1 year from date of purchase, WILMAR will replace at no charge any parts which our examination shall disclose to be defective and under warranty.

The provisions of this warranty shall not apply to any part which is used for a purpose for which it is not designed, or which shall have been repaired or altered in any way so as to affect adversely its performance and reliability, nor shall this warranty apply to any part which has been subject to misuse, neglect or accident.

WILMAR does not authorize any other person to assume any liability in connection with its product and the implied warranty of merchantability and fitness as limited to the duration of this warranty. Some states do not allow limitations on how long an implied warranty lasts, so the above limitations may not apply to you.

© Copyright 2002 Wilmar Corporation - All rights reserved.

On occasion, after printing of our literature is completed, our manufacturers may make changes and/or modifications to merchandise which will not be reflected in this manual. Although we strive to maintain complete and accurate information, it is possible in some instances, that the product may differ slightly from printed specifications. Illustrations are intended for reference only. Actual merchandise may vary. Wilmar is not responsible for typographical errors.

## PARTS LIST

Carefully unpack and spread out all parts in a large uncluttered area. Familiarize yourself with all parts and compare them to the drawing below to make sure none are missing.

Read all assembly instructions before beginning.

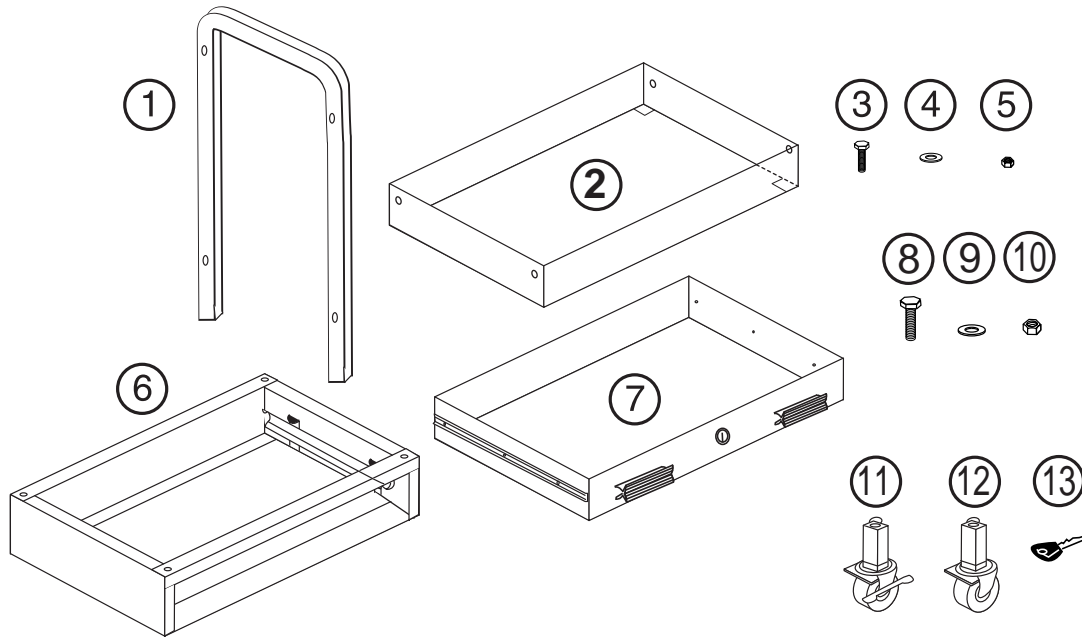

#	Description	Qty.	#	Description	Qty.
1	Handle	2	9	3/4" Bolt	8
2	Shelf	2	10	Large washer	8
3	1-1/2" Bolt	8	11	14mm Hex Nut	8
4	Small washer	8	12	Key	2
5	10mm Hex Nut	8	13	Drawer back cover	1
6	Crossbar	2	14	Locking Swivel Caster	2
7	Drawer	1	15	Swivel Caster	2
8	Side bracket with drawer rail	2	16	Caster Holder	4

## ASSEMBLY INSTRUCTIONS

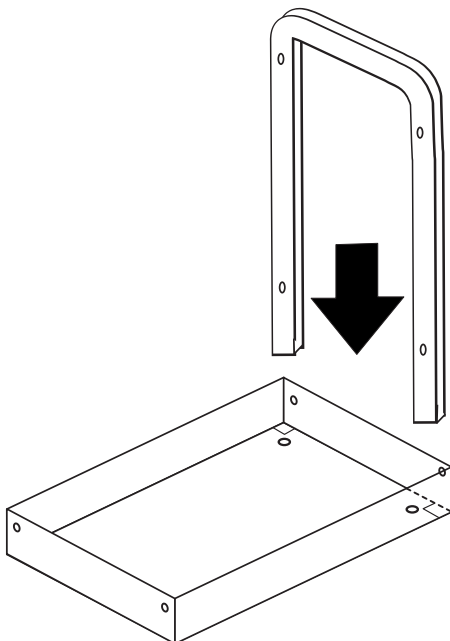

Tools Required: (not included)

10mm wrench or socket

14mm wrench or socket

Rubber mallet

- Slide a handle (1) through the holes on one end of the shelf (2).
- Line up the holes nearest the bend in the handle with the holes on the side of the shelf.
- Insert bolts (3) through the shelf and the handle and secure with a washer (4) and hex nut (5).

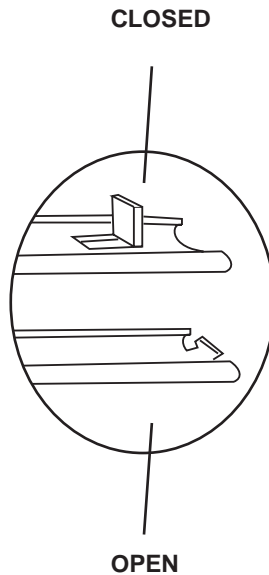
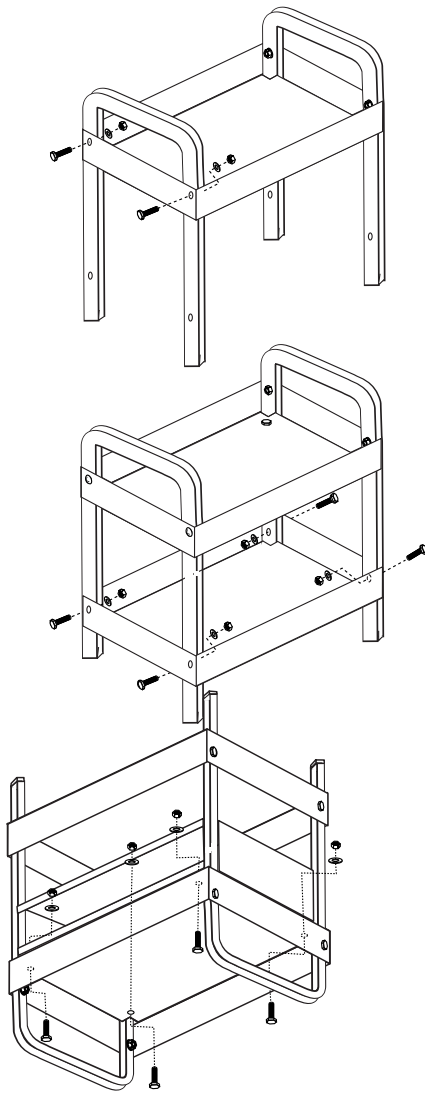

4. Slide the remaining handle through the shelf on the opposite end, and repeat steps 2 thru 3.
5. Slide the remaining shelf onto the handle, lining up the holes on the side of the shelf with the holes on the handle nearest the bottom of the cart.
6. Insert bolts (3) through the shelf and handle on all four corners and secure with a washer (4) and hex nut (5).
7. Go back and check to make sure all fasteners are tight.
8. Turn utility cart upside down and place on a flat surface.
9. Place a cross bar (6), both side brackets (8) and back drawer cover (13) onto underside of the top shelf. (NOTE: Make sure the rails on the side brackets are facing toward each other. The closed ends of the rails must face the drawer back cover or rear of the cart, when attached to the utility cart. See close up.)
10. Align the holes on the crossbar (6), both side brackets (8) and back drawer cover (13) with the holes in the corners of the shelf underside.
11. Insert bolts (9) through the shelf at each corner, attaching the crossbar (6), both side brackets (8) and back drawer cover, and secure each bolt with a washer (10) and 14mm hex nut (11).
12. Attach remaining crossbar (6) to side brackets (8) and fasten together with bolts (9), washers (10) and hex nuts (11).
13. Fasten together the side brackets (8) to the drawer back cover (13) with bolts (9), washers (10) and hex nuts (11).
14. Go back and check to make sure all fasteners are tight.

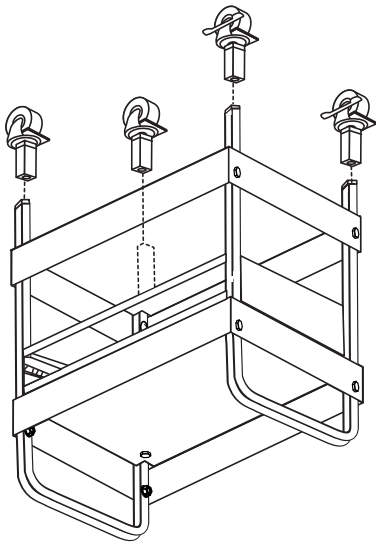

16. With the utility cart still upside down, insert the smaller end of the caster holders into the hollow ends of the handles. (NOTE: If necessary, use a rubber or plastic mallet to seat holders into handles completely.)

17. Attach the locking casters to one end of the cart by inserting the pins on the caster into the castor holders. (NOTE: If necessary, use a rubber or plastic mallet to seat casters into the caster holders completely.)

18. Repeat step 9 with the non-locking castors on the other end of the cart.

19. Carefully flip the cart back to its up-right position.

20. Slide drawer into open area at front of utility cart. (NOTE: While attaching drawer, insure that the rails on the sides of the drawer are inserted into the drawer support rails located on the inside of the side brackets (8). If the drawer will not slide into the side bracket rails, the side brackets may have been installed upside down. Refer to step 10.)

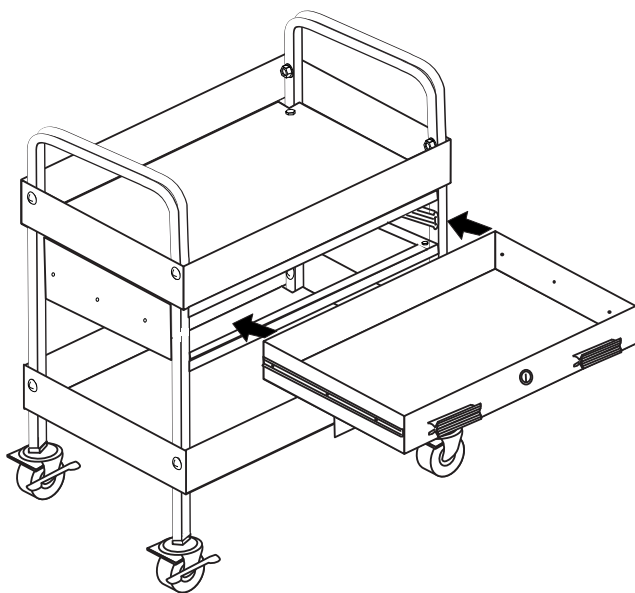

#### LOCKING DRAWER:

To lock drawer:

1. Close drawer completely.
2. Insert key (12) into keyhole and turn 90° counter clockwise.
3. Remove key and pull on drawer handle to make sure lock is engaged.

To unlock drawer:

1. Insert key into keyhole and turn 90° clockwise.
2. Remove key and pull drawer open.
3. Store key safely.