

19.2 VOLT CORDLESS DRILL

Item Number W50092

OWNER'S MANUAL



Performance Tool®

▲WARNING

It is the owner and/or operators' responsibility to study all WARNINGS, operating, and maintenance instructions contained on the product label and instruction manual prior to operation of this product. The owner/operator shall retain product instructions for future reference.

The owner and/or operator are responsible for maintenance, maintaining all decals or warning labels and while in use, maintaining the unit in good working order. If the owner and/or operator are not fluent in English, the product warnings and instructions shall be read and discussed with the operators' native language by the purchaser/owner or his designee. Make sure that the operator comprehends its contents. Safety information shall be emphasized and understood prior to usage. The product shall be inspected per the operating instructions.

Users of this product must fully understand these instructions. Each person operating this product must also be of sound mind and body and must not be under the influence of any substance that might impair their vision, dexterity or judgment.

Protect yourself and others by observing all safety information.

Failure to comply with instructions could result in personal injury and/or property damage!

PT
Performance Tool®

SAFETY GUIDELINES / DEFINITIONS

This instruction manual is intended for your benefit. Please read and follow the safety, installation, maintenance and troubleshooting steps described within to ensure your safety and satisfaction. The contents of this instruction manual are based upon the latest product information available at the time of publication. The manufacturer reserves the right to make product changes at any time without notice.

⚠ WARNING: Read and understand this entire instruction manual before attempting to assemble, install, operate or maintain this product. Failure to comply with the instructions may result in serious personal injury and/or property damage!

The following signal words are used to emphasize safety warnings that must be followed when using this product:

⚠ DANGER Indicates an imminently hazardous situation that, if not avoided, WILL result in death or serious injury.

⚠ WARNING Indicates a potentially hazardous situation that, if not avoided, COULD result in death or serious injury.

⚠ CAUTION Indicates a potentially hazardous situation that, if not avoided, MAY result in minor or moderate injury.

⚠ NOTICE Indicates important information, which if not followed, MAY cause damage to equipment.

UNPACKING AND INSPECTION

After opening the carton, unpack your new product and related parts & accessories. Please inspect it carefully for any damage that may have occurred during transit. Please check it against the photograph on carton.

⚠ WARNING DO NOT operate this product if damaged during shipment, handling or misuse. Do not operate the product until the parts have been replaced or the fault rectified. Failure to do so may result in serious personal injury or property damage. All damaged parts must be repaired or replaced as needed prior to operating this product. Check to see that all nuts, bolts and fittings are secure before putting this product into service.

Please have the serial number, model number, and date of purchase available for reference when calling.

SPECIFICATIONS

Voltage	19.2 Volt
Torque Positions	16+1
RPM (No Load)	0 - 550
Chuck Capacity	3/8 in.
Charger Input	120 Volts AC 60HZ
Charging Time	3-5 hrs.
Battery Type	Nickel Cadmium

Specifications are subject to change without notice.

IMPORTANT SAFETY INFORMATION

⚠ WARNING
READ, UNDERSTAND AND FOLLOW ALL INSTRUCTIONS AND WARNINGS BEFORE OPERATING THIS PRODUCT. FAILURE TO DO SO MAY RESULT IN PERSONAL INJURY AND/OR PROPERTY DAMAGE AND WILL VOID WARRANTY.

1. Always use common sense and pay particular attention to all the DANGER, WARNING, CAUTION and NOTICE statements of this manual. The safety instructions provided are not intended to cover all possible conditions and practices that may occur when operating, maintaining and cleaning power tools.
2. Observe work area conditions. Do not use machines or power tools in damp or wet locations. Don't expose to rain. Keep work area well lighted. Do not use electrically powered tools in the presence of flammable gases or liquids. Do not bring combustible materials near the tools. Power tools create sparks, which may ignite the dust or fumes.

Keep work area clean and well lit. Cluttered work areas invite accidents.

3. Use personal protective equipment. Wear ANSI approved safety goggles. Protective equipment such as dusk mask, non-skid safety shoes, hard hat, heavy duty work gloves or hearing protection used for appropriate conditions will reduce personal injuries.
4. Keep bystanders, children and visitors away while operating this product. Distractions can cause you to lose control.
5. Stay alert. Watch what you are doing, and use common sense when operating this product. Do not use this product

IMPORTANT SAFETY INFORMATION

- while tired or under the influence of drugs, alcohol, or medication. A moment of inattention while operating this product may result in serious personal injury. Keep proper footing and balance at all times. Do not reach over or across running machines, hoses, cords, etc.
- Dress properly. Do not wear loose clothing or jewelry. Keep your hair, clothing, and gloves away from moving parts. Loose clothes, jewelry or long hair can be caught in moving parts.
 - Inspect before every use; do not use if parts are loose or damaged.
 - Do not alter this product in any way.
 - Use the right tool for the job. Do not attempt to force a small tool or attachment to do the work of a larger industrial tool. Don't use a tool whose performance is not adequate for your work. Do not modify this tool and do not use this tool for a purpose for which it was not intended.
 - Power tool plugs must match the outlet. Never modify the plug in any way. Do not use any adapter plugs with earthed (grounded) power tools. Unmodified plugs and matching outlets will reduce risk of electric shock.
 - Avoid body contact with earthed or grounded surfaces such as pipes, radiators, ranges and refrigerators. There is an increased risk of electric shock if your body is earthed or grounded.
 - Do not expose power tools to rain or wet conditions. Water entering a power tool will increase the risk of electric shock.
 - Do not abuse the cord. Never use the cord for carrying, pulling or unplugging the power tool. Keep cord away from heat, oil, sharp edges or moving parts. Damaged or entangled cords increase the risk of electric shock.
 - When operating a power tool outdoors, use an extension cord suitable for outdoor use. Use of a cord suitable for outdoor use reduces the risk of electric shock.
 - If operating a power tool in a damp location is unavoidable, use a ground fault circuit interrupter (GFCI) protected supply. Use of a GFCI reduces the risk of electric shock.
 - Before using battery pack, please read carefully all instructions and cautionary markings on battery pack, battery charger and product using battery. Do not incinerate the battery pack even if it is severely damaged or is completely worn out. The battery pack can explode.
 - Do not carry battery packs in aprons, pockets, or tool boxes, product kit boxes, drawers, etc. with loose metal objects. Battery pack terminals could be short-circuited causing damage to the battery pack, severe burns or fire.
 - The battery pack is Nickel-Cadmium (Ni-Cad) and is considered to be a toxic material by the Environmental Protection Agency. Before disposing of damaged or worn out Ni-Cad battery packs, check with your State Environmental Protection Agency to find out about special restrictions on the disposal of these battery packs.
 - The battery is not fully charged. Before first use, the battery pack requires 8-10 hours charge time to be fully charged. Subsequent recharging needs 3-5 hours for the battery to be fully charged.
 - Always switch to a fresh battery when tool performance begins to diminish. Severe heat is most destructive to a battery; the more heat generated, the faster the battery loses power. A battery that gets too hot can have a shortened life.
 - Never over-discharge a battery by using the tool even after tool performance has decreased. Do not attempt to discharge a tool's battery by continuing to pull on the tool trigger. When tool performance begins to diminish, stop the tool and recharge the battery for optimal performance.
 - Charge battery pack at ambient temperatures between 50° F -104° F. Store tool and battery pack in locations where temperatures will not exceed 120°F. This is important to prevent serious damage to the battery cells.
 - A battery operated tool with integral batteries or a separate battery pack must be recharged only with the specified charger for the battery. A charger that may be suitable for one type of battery may create a risk of fire when used with another battery. Use battery operated tool only with specifically designated battery pack. Use of any other batteries may create risk of fire.
 - When battery pack is not in use, keep it away from other metal objects, like paper clips, coins, keys, nails, screws or other small metal objects, that can make a connection from one terminal to another. Shorting the battery terminals together may cause burns or a fire.
 - Under abusive conditions, liquid may be ejected from the battery; avoid contact. If contact accidentally occurs, flush with water. If liquid contacts eyes, additionally seek medical help. Liquid ejected from the battery may cause irritation or burns.
 - Prevent accidental starting. Ensure switch is in the "OFF" position before connecting to power source and/or battery pack, picking up or carrying the tool. Carrying power tools with your finger on the switch or energizing power tools that have the switch "ON" invites accidents.
 - Do not use the power tool if the switch does not turn it on and off. Any power tool that cannot be controlled with the switch is dangerous and must be repaired.
 - Have your power tool serviced by a qualified repair person using only identical replacement parts. This will ensure that the safety of the power tool is maintained. Follow instructions in the Maintenance section of this manual. Use of unauthorized parts or failure to follow Maintenance Instructions may create a risk of shock or injury.
 - Disconnect the plug from the power source and/or the battery pack from the power tool before making any adjustments or changing accessories. Such preventive safety measures reduce the risk of starting the power tool accidentally.
 - Maintain power tools. Check for misalignment or binding of moving parts, breakage of parts and any other condition that may affect the power tool's operation. If damaged, have the power tool repaired before use. Many accidents are caused by poorly maintained power tools.
 - Keep cutting tools sharp and clean. Properly maintained cutting tools with sharp cutting edges are less likely to bind and are easier to control.
 - Use the power tool, accessories and tool bits etc. in accordance with these instructions, taking into account the working conditions and the work to be performed.

IMPORTANT SAFETY INFORMATION

Use of the power tool for operations different from those intended could result in a hazardous situation.





33. Store idle equipment. When not in use, tools must be stored in a dry location to inhibit rust. Always lock up tools and keep out of reach of children and other untrained persons. Switch off all unused electrical tools when stored. Disconnect battery from unit. Tools are dangerous in the hands of untrained users.

⚠ WARNING: Some dust created by power sanding, sawing, grinding, drilling and other construction activities contains chemicals known to the State of California to cause cancer, birth defects or other reproductive harm.

⚠ WARNING: This product and its packaging contain a chemical known to the State of California to cause cancer, birth defects, or other reproductive harm.

SYMBOL DEFINITIONS

IMPORTANT: Some of the following symbols may be used on your tool. Please study them and learn their meaning. Proper interpretation of these symbols will allow you to operate the tool better and safer.

Symbol	Name	Explanation
V	Volts	Voltage (Potential)
A	Amperes	Current
Hz	Hertz	Frequency (Cycles per Second)
W	Watt	Power
Kg	Kilograms	Weight
	Alternating Current	Type of Current
	Direct Current	Type of Current
	Alternating or Direct Current	Type of Current
	Earthing Terminal	Grounding Terminal
	Class II Construction	Denotes Double Insulation
min	Minutes	Time
s	Seconds	Time
∅	Diameter	Size of Drill Bits, Grinding Wheels, etc.
n_0	No load speed	No-load Rotational Speed
.../min	Revolutions per Minute	Revolutions, Surface Speed, Strokes, etc. per Minute
1,2,3,...	Ring Selector Settings	Speed, Torque or Position Settings

CONTROLS AND COMPONENTS

1. Battery Pack
2. Release Buttons on Each Side
3. Charger
4. LED Charging Indicators
5. 10 mm (3/8 in.) Keyless Chuck
6. 16 +1 Adjustable Torque Settings Control Ring
7. Forward/Reversing and Trigger Lock Lever
8. Variable Speed Controlled Trigger Switch
9. Comfort Grip
10. 120V AC adapter
11. LED Light

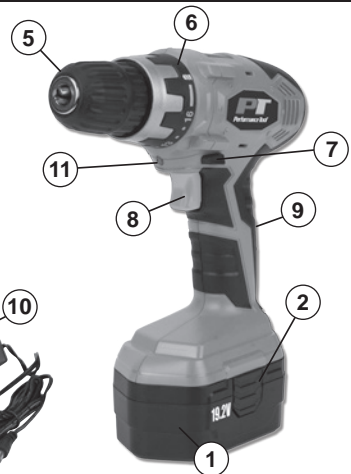

BATTERY PACK USAGE AND CHARGING OPERATIONS

BATTERY PACK INSTALLATION

TO REMOVE BATTERY PACK:

1. Press release button on front side of the Cordless Drill to release the battery pack.
2. Pull battery pack free of Cordless Drill.

TO ATTACH BATTERY PACK:

1. Align the raised portion of the battery pack with the groove in the battery compartment of the Cordless Drill.
2. Press the battery pack into place. Make sure the latch is securely fastened. Do not use the Cordless Drill if the battery pack is not seated properly.



BATTERY PACK CHARGING OPERATIONS

▲ NOTICE The charger will not automatically turn “OFF” when the battery pack is fully charged. The charging indicator light will remain “ON” until the charger is disconnected from the electrical outlet. Remove battery pack from charger and disconnect charger from power after 5 hours of charging operation. Overcharging can overheat battery cells and cause permanent damage to the battery pack and charger kit.

1. Make sure the trigger on the Cordless Drill is in the “OFF” position and remove the battery pack from the Cordless Drill.
2. Plug 120V AC Adapter into household outlet and into side of battery charger. The Red indicator light will come “ON”.

3. Insert battery pack into battery charger. The Green indicator light will come “ON” indicating that battery is being charged.
4. After 3 - 5 hours of charging, remove the battery pack from charger and reattach battery pack onto Cordless Drill, making certain latches fasten securely. Cordless Drill will not operate properly if the battery pack is not seated properly.

▲ NOTICE Continuous use of your tool causes the battery pack to become hot. Let a hot battery pack cool down for approximately 30 minutes before attempting to recharge.

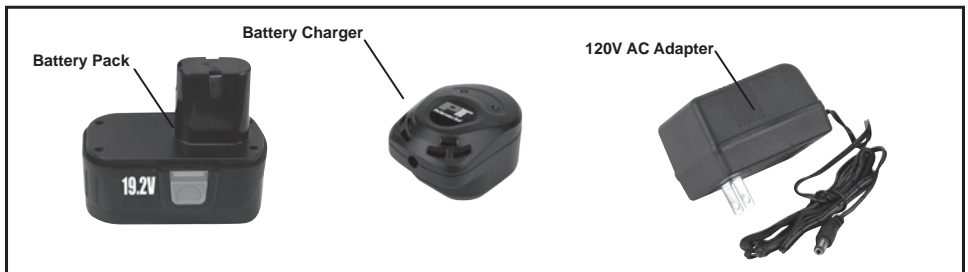

OPERATION

⚠ WARNING Be aware that this tool is always in an operating condition because it does not have to be plugged into an electrical outlet. Always lock the Trigger Switch and remove the battery pack before changing accessories.

INSTALLING ACCESSORIES

⚠ WARNING Do not attempt to tighten drill bits (or any other accessory) by gripping the front of the chuck and turning the tool on. This may cause personal injury and/or damage to the chuck. When removing the bit from the tool, avoid contact with skin and use proper protective gloves when grasping the bit or accessory. Accessories may be hot after prolonged use.

⚠ CAUTION Be aware that this tool is always in an operating condition because it does not have to be plugged into an electrical outlet. Always lock the Trigger Switch and remove the battery pack before changing accessories.

1. Hold the rear end of the chuck in one hand and use the other hand to rotate the front end in a clockwise direction to open the jaws of the chuck.
2. Insert the shank of the bit (or other accessory) fully into the keyless chuck, taking care to keep the bit in the center of the jaws of the chuck.
3. Turn the front end of the chuck counterclockwise to hold the bit in place.
4. Tighten securely by turning the front end of the chuck counterclockwise while holding the rear end.

OPERATING THE DRILL

⚠ WARNING Never tape the trigger switch down to provide continuous high speed.

The tool may fail under such conditions causing fire or personal injury.

VARIABLE SPEED TRIGGER SWITCH:

- The speed of the Cordless Drill depends on the amount of pressure you put on the trigger.
- The more pressure you apply, the faster the Cordless Drill will go.
- Release the pressure and the Cordless Drill will slow down.

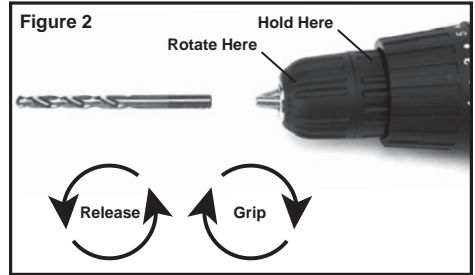

FORWARD / REVERSE AND TRIGGER LOCK LEVER:

⚠ NOTICE Be sure the trigger is released when changing the position of the lever. Always store the tool in the "LOCKED/OFF" position. Always check the direction of the Cordless Drill's rotation before use.

- To select forward Cordless Drill rotation, press the trigger lock from left to right flat against the Cordless Drill body.
- To select reverse, press the trigger lock lever in the opposite direction.
- The center position locks the tool.



OPERATION

TORQUE SETTINGS

NOTE: The control ring adjusts the level of torque

- For light duty work, use lower settings.
- For heavy duty work, use higher settings.

Proper Setting For Driving Screws:

1. Set the ring on the lowest setting to begin.
2. Try tightening the first screw. If the drill drives smoothly, proceed with the next screw.
3. If the Drill's clutch slips, increase the torque setting and try again until the Drill drives the screw without incident.

SCREWDRIVING

- Always start slowly and gradually increase the speed of the Drill.
- Release the trigger when you feel the clutch slip.
- Always keep the driver bit straight to prevent damage to the screw.
- Hold the Drill with both hands to ensure control if the bit should stick or slip.
- To prevent wood from splitting, drill pilot holes into the wood before driving in the screws.

DRILLING METAL

- Apply a lubricant, such as cutting oil, to the tip of the bit.
- Start with a small hole then enlarge to the required size. Make sure the bit is actually cutting and not spinning in the hole as this will dull the edges of the bit.
- Keep enough pressure on the bit to keep it drilling through the material.

DRILLING MASONRY

- Masonry can be brittle so be careful not to apply too much pressure and crack the material.
- Apply enough pressure to keep the bit

cutting and not spinning in the hole as this will dull the edges of the bit.

- Bricks and similar soft materials will require less pressure, concrete will require much more.

DRILLING WOOD

Use twist bits to drill holes in wood. Make sure the bits are sharp. Pull the bits out of the hole frequently to clear chips from the flutes as an overburdened bit may overheat.

TIPS FOR OPTIMAL USE

- Keep the right amount of pressure in a straight line with the drill bit. Too little and the bit will spin without cutting, too much and the motor may stall.
- Just before the drill tip breaks through the other side of the work piece drill more slowly and decrease pressure on the tool. This will prevent stalling and leave a cleaner hole.
- Use a block of wood to back up work pieces that may splinter.
- Use spade bits when drilling large diameter holes in wood.
- Use HSS drill bits when drilling in metal.
- Use masonry bits when drilling in soft masonry.
- Use a lubricant when drilling metals other than cast iron, aluminum, copper, and brass.
- When drilling, start the hole slowly, allowing the bit to drill deep enough to prevent slipping at higher speeds.
- Never try to start a stalled Drill by clicking the trigger switch "ON" and "OFF". This may damage your tool.
- To reduce jamming, always keep the Drill running when pulling the bit out of a finished hole.

ACCESSORIES

Use only accessories that are recommended by the manufacturer for your model. Accessories that may be suitable for one tool may become hazardous when used on another tool.

Always attach grounded (3-prong) extension cords to grounded (3-hole) outlets. If you must use an extension cord, be sure that the gauge is large enough to carry the amount of current necessary for your power tool. If not, your tool may experience a loss of power, excessive voltage drop or overheating. The smaller the gauge number, the heavier the cord (see table below).

CARE & MAINTENANCE

▲ WARNING Always remove the battery pack before attempting cleaning or maintenance.

▲ NOTICE This Cordless Drill is lubricated before it leaves the factory. This lubrication should last for the life of the tool. No further lubrication is required.

Use only mild soap and a damp cloth to clean the tool. Never let any liquid get inside the casing. Never

immerse any part of the tool in a liquid. Always keep the ventilation openings clear.

Always clean the battery pack using only a dry cloth. Do not use liquids.

Always unplug the charger before cleaning it.

Regularly clean the ventilation slots in your tool and charger using only a soft brush or dry cloth.

Never open the Cordless Drill case, battery pack or charger. Do not attempt to repair the Cordless Drill, battery pack or charger yourself. Opening any of these parts will void your warranty.