

8" Bench Grinder

Stock Number W50058

OWNER'S MANUAL



TABLE OF CONTENTS

Safety Instructions	2
Bench Grinder Safety	3
Electrical Requirements.....	3
Replacement Parts List.....	4
Bench Grinder Assembly.....	4
Maintenance.....	5
Warranty	6

SPECIFICATIONS

Maximum HP developed	3/4
Volts.....	115
Hertz.....	60
RPM	3450 (no load speed)
GRINDING WHEEL SIZE.....	8" X 1" X 5/8"
GRINDING WHEEL GRIT	36 & 60
LEFT & RIGHT TOOL RESTS	
LEFT & RIGHT EYE SHIELDS AND ASSEMBLIES	
LEFT & RIGHT SPARK GUARDS	

PROTECT YOUR EYES.
The operation of any power tool can result in foreign objects being thrown into the eyes which can result in severe eye damage. Always wear eye protection during power tool operation.



To avoid electrical shock to yourself and damage to the bench grinder, use proper circuit protection.
The Bench grinder is factory wired for 115V, 60 Hz operation. Connect to a 115V, 15 amp branch circuit and use a 15 amp time delay fuse or circuit breaker. The electrical circuit can not have any wire size less than #12. To avoid shock or fire, replace power cord immediately if it is damaged in any way.

SAFETY INFORMATION

Carefully read through the entire owner's manual before operating your bench grinder. Keep manual with important records for safety instructions, operating procedures and warranty.



WARNING: When using electrical tools, machines or equipment, basic safety precautions should always be followed to minimize the risk of fire, electrical shock or personal injury to yourself and others.

BEFORE USING YOUR BENCH GRINDER

• READ THE ENTIRE MANUAL.

• **GROUND ALL TOOLS.** Any tool supplied with a 3-prong plug must be plugged into a 3-contact electrical receptacle. The 3rd prong is used to ground the tool and provide protection against accidental electrical shock. Never remove the third prong.

• **AVOID DANGEROUS ENVIRONMENTS.** Do not use power tools near gasoline or other flammable materials, in damp or wet locations or expose them to rain. Keep work area well lit. Normal sparking of the motor or sparking from grinding metal could ignite fumes.

• **KEEP WORK AREA CLEAN.** Messy areas and cluttered work benches invite personal injury and or property damage.

• **KEEP CHILDREN AND VISITORS AWAY.** All children should be kept away from the work area. Maintain a safe distance for any person near the work area. Adults near the work area must wear safety glasses. DO NOT let children handle the power tool or extension cord.

• **DRUGS, ALCOHOL, MEDICATION.** Operating any tool or equipment under the influence of drugs, alcohol, and or medication can cause personal injury to yourself and others.

• **WEAR PROPER APPAREL.** Remove your jewelry before using tool. DO NOT wear loose clothing, neckties, rings, bracelets, or other jewelry which may get caught in moving parts. Non skid footwear and non-electrically conductive gloves are highly suggested while working. Wear protective hair covering to contain long hair.

• PROTECT YOUR EYES.

The operation of any power tool can result in foreign objects being thrown into the eyes which can result in severe eye damage. Always wear eye protection during power tool operation. Eyeglasses are not always safety glasses.

• **BE RESPONSIBLE FOR YOUR HEARING AND BREATHING.** Wear hearing protection during extended periods of operation. Protect your lungs by wearing a clean face or dust mask.

• **GUARD AGAINST ELECTRICAL SHOCK.** Avoid body contact with grounded surfaces such as pipes, radiators, ovens, stoves and refrigerator enclosures.

• **USE THE RIGHT TOOL.** Use tools properly and for its intended task. DO NOT force a small tool to do the job of a heavy duty tool. Using the right tool to do the right job will do the job intended and safer.

• **CHECK DAMAGED PARTS.** Before use of a tool, a guard or other part that is damaged, it should be carefully checked to assure that it will operate properly and perform its intended function. Check for misalignment or binding of moving parts, breakage of parts, mounting, or any other conditions that may affect its operation. A guard or other part that is damaged should be properly replaced. See Replacement parts list on page 4.

• **AVOID UNINTENTIONAL STARTING.** Be sure that your power tool is in the "OFF" position before plugging it into a power cord or electrical receptacle.

• **STORE ALL MAINTENANCE TOOLS** away from the immediate area prior to turning "ON" your bench grinder.

• **DO NOT OVERREACH.** Proper footing and balance is a must at all times while using the tool. Unstable support may lead to personal injury.

• **DO NOT STAND ON THE TOOL.** Serious injury could result if the tool tips over or you accidentally contact the tool.

• **NEVER LEAVE TOOL RUNNING UNATTENDED.** ALWAYS turn the power to the "OFF" position and do not leave the tool until it comes to a complete stop.

• **USE RECOMMENDED ACCESSORIES.** Consult the owners manual for recommended accessories. The use of improper accessories may cause risk of injury to yourself and others.

• **ALWAYS MAKE SURE THE TOOL IS IN THE "OFF" POSITION AND UNPLUGGED** from the electrical receptacle when making adjustments, changing parts or performing any maintenance,

• **SECURE WORK.** When possible the use of clamps or a holding device is much safer than holding the workpiece with your hands.

• **KEEP PROTECTIVE GUARDS IN PLACE AND IN PROPER WORKING CONDITION.**

• **MAINTAIN TOOLS WITH CARE.** Tools function better and safer when kept clean and in good working condition. Keeping the tool clean, dry, free of grime will add to its life and performance.

• **CHILDPROOF THE WORKSHOP.** The use of master switches and padlocks is highly suggested. Remove starter keys.

• **EXTENSION CORD GUIDELINES.** Use only 3-wire extension cords that have 3-prong grounding type plugs and 3 prong receptacles that accept the tool's plug. Only UL listed extension cords should be used with this product. Improper use of extension cords may cause inefficient operation of your tool which can result in overheating. Be sure your extension cord is rated to allow sufficient flow to the motor. Refer to guide below for minimum gauge for extension cords.

EXTENSION CORD LENGTH	WIRE SIZE (A.W.G.)
Up to 25 feet	16
26 to 50 feet	16
51 to 100 feet	16

The use of an extension cord heavy enough to carry the current a tool will draw is very important. Especially when the power source is of great distance. A extension cord that is insufficient will cause a drop in line voltage, resulting in power loss and causing the motor to overheat. When the project requires you to be outdoors, use an extension cord designed for outdoor use. The letters "WA" are indicated on the jacket of the cord.

ELECTRICAL REQUIREMENTS

CONNECTING TOOL TO POWER SOURCE OUTLET

This machine source must be grounded while in use to protect the operator from electric shock. In the event of a malfunction or breakdown, grounding provides a path of least resistance for electric current to reduce the risk of electric shock. This tool is equipped with an electric cord having an equipment grounding conductor and a grounding plug. The plug must be plugged into a matching outlet that is properly installed and grounded in accordance with all local codes and ordinances.

Improper connection of the equipment grounding conductor can result in a risk of electric shock. The conductor with insulation having an outer surface that is green (with or without yellow stripes) is the equipment grounding conductor. If repair or replacement of the electric cord or plug is necessary, **DO NOT** connect the equipment - grounding conductor to a live terminal. **DO NOT MODIFY THE PLUG PROVIDED.** If it will not fit the receptacle, have the proper receptacle installed by a qualified electrician. Check with a qualified electrician or service personnel if the grounding instructions are not completely understood, or if in doubt as to if the tool is properly grounded.

Fig. A

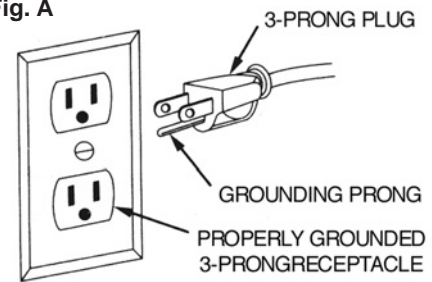

This tool is intended for use on a circuit that has an outlet that looks like the one illustrated in Figure A. The tool has a grounding plug that looks like the one also shown in Figure A. **DO NOT** modify the plug provided if it will not fit the outlet. Have the proper outlet installed by a professional electrician.



WARNING: If not properly grounded, this power tool can incur the potential hazard of electrical shock particularly when used in damp locations or in proximity to plumbing. If an electrical shock occurs, there is the potential of a secondary hazard such as your hands contacting the grinder tool.

BENCH GRINDER SAFETY

USE THE WHEEL GUARDS AND SAFETY EYE SHIELDS that are provided with your bench grinder.

USE ONLY GRINDING WHEELS that are rated at higher RPM than the maximum RPM of your bench grinder.

CRACKED OR DAMAGED GRINDING WHEELS. Replace immediately cracked or damaged grinding wheels that can give out debris at a high speed. Handle the grinding wheel carefully since they are abrasive. Check the replacement wheel for cracks prior to installing. **DO NOT** remove the label or blotter on both sides of the grinding wheel. The spindle nut should be tightened just enough to hold the wheel firmly to your bench grinder. It is possible to damage the grinding wheel with too much clamping force.

DO NOT use the bench grinder if the flange nut or clamp nut is missing or if the spindle shaft is bent.

GRINDING WHEELS will get smaller with use. The distance between the work rest and wheel must be periodically adjusted to 1/16".

DO NOT START GRINDER when the grinding wheel is in contact with the workpiece.

GENTLY apply the workpiece against the grinding wheel when starting your project. A sudden impact can damage the wheel. The use of slight pressure is best when starting to grind. The use of too much pressure too quickly on a cold wheel can cause damage to the wheel.



WARNING: Some dust created by grinding and other construction activities contains chemicals known to cause cancer, birth defects or other reproductive harm. Some examples of these chemicals are: **LEAD** from lead based paint, **CRYSTALLINE SILICA** from bricks and cement and other masonry products, **ARSENIC** and **CHROMIUM** from chemically treated lumber. Your risk from these exposures varies, depending on how often you do this type of work. To reduce your exposure to these chemicals: work in a well ventilated area, and work with approved safety equipment, such as those dust masks that are especially designed to filter out microscopic particles.

DO NOT STAND directly in front of the bench grinder when starting. When turning the bench grinder to the "ON" position, stand to one side. There is always the possibility of debris discharged toward the operator.

INSPECT TOOL CORDS AND EXTENSION CORDS. If damaged, have repaired or replaced immediately. Know their location, keep them well away from the grinding wheel.

BENCH GRINDERS will emit sparks and produce debris. **DO NOT** use power tools where flammable gas or liquids exist. Clean your bench grinder and area of grinding dust.

KEEP IN MIND. Stay alert and aware of what you are doing. The slightest mistake can cause personal injury and or property damage.

YOUR BENCH GRINDER MUST be securely mounted to a suitable workspace before operating. (hardware not included)

PLAN YOUR PROJECT. Avoid awkward operations and hand positions where a sudden slip could cause personal injury. Hold the workpiece firmly and keep body parts a safe distance from grinding wheels.

WHEEL GUARDS, KEEP THEM IN PLACE. **DO NOT** operate the bench grinder with the wheel guards removed.

KEEP TOOL RESTS FIRMLY TIGHTENED.

PROTECT YOUR EYES.

The operation of any power tool can result in foreign objects being thrown into the eyes which can result in severe eye damage. Always wear eye protection during power tool operation.



BENCH GRINDER ASSEMBLY

LOOSE PARTS CONTENTS:

Tool Rest	2 each
Mounting rods	2 each
Eye Shields	2 each
Brackets	2 each
Spark Guard	2 each
3/4" Bolts	2 each
1/2" Bolts	4 each
5/8" Bolts	2 each
Large Washers	6 each
Washers	2 each

The following tools (not included) are needed for assembly and alignment: 8, 10, and 12mm Combination wrench, Phillips screwdriver, Adjustable wrench



WARNING: If any parts are missing DO NOT operate this machine until the missing parts are replaced. Failure to do so could result in possible serious injury.

DO NOT begin assembly of your bench grinder until you are certain the tool is NOT plugged in.

DO NOT begin assembly until you are certain the bench grinder is in the "OFF" position.

DO NOT begin assembly until you are certain that the grinding wheels are securely tightened to your bench grinder.

- 1. Inspection-** To be certain the grinding wheels have not been damaged in shipment, inspect carefully. If you suspect a wheel of being fractured, REPLACE IMMEDIATELY. Fractured wheels may shatter causing serious injury or property damage.
2. Mount bench grinder (hardware not included) on a firm level surface where there is plenty of room for handling and properly supporting the workpiece. Keep in mind the nearest electrical receptacle.
3. Avoid a dangerous environment. Use the grinder in a dry, indoor place protected from the rain. Keep work area well lit.
4. Disconnect tools before servicing or when changing accessories such as grinding wheel.
5. Keep guards in place and in working order. To avoid accidental starting, make sure the power switch is in the "OFF" position before plugging in.
6. Use recommended accessories. Consult the owners manual for recommended accessories. The use of improper accessories may cause risk of injury to yourself and others.

INSTALLING TOOL RESTS

Remove the tool rests from the package and install them to the wheel guards as shown in Figure 1. Use the bolts and washers to secure them in place.

Note: There is a left and right tool rest. Refer to Figure 1 to ensure that you install them correctly.

When in actual use, the tool rests should be adjusted to within 1/16" of the grinding wheel.

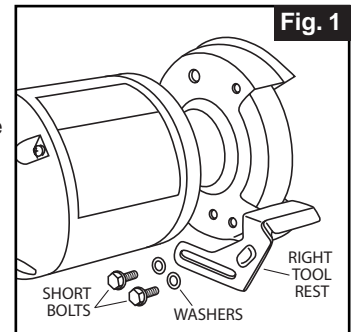

INSTALLING THE SPARK GUARDS

Select the two spark guards and the two smaller bolts and washers. Install the spark guards to the wheel guards of your grinder as shown in Figure 2. Adjust them to within 1/16" of the grinding wheel.

Note: There is a left and right spark guard. Refer to Figure 2 to ensure that you install them correctly.

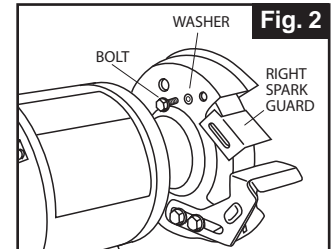

INSTALLING THE EYE SHIELDS

Note: There is a left and right eye shield mounting rod. Examine Figure 3 to ensure that you install them correctly. The one pictured in Figure 3 is for the right wheel guard as you face the front of the tool. Assemble one mounting rod, one bracket, one bolt as shown and install it to the wheel guard of the grinder. Position it with the arm high, as shown in Figure 4, and tighten the bolt securely.

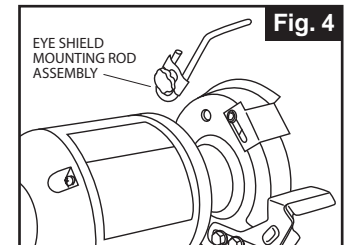
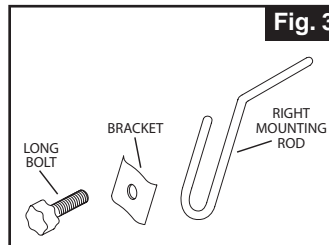

Note: The eye shields are identical and will fit properly on either side of the grinder. However it may be necessary to loosen the center hex nut in order to slip the shield over the mounting rod.

After you have installed each eye shield mounting rod to the grinder, attach the eye shields to the rods, as shown in Figure 5. Install them in such a way that the three hex nuts on each eye shield are on the back side, away from the operator when the tool is in use.

Tighten the center hex nut so that the shield can be moved but will be tight enough to stay in place. ALWAYS position the eye shields between your eyes and the grinding wheel.

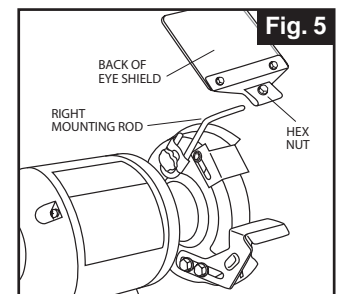

MAINTENANCE



WARNING: For your own safety, turn switch “OFF” and remove plug from power source outlet before adjusting and maintaining your bench grinder. If power cord is worn, cut, or damaged in any way, have it replaced immediately.

CARE FOR GRINDING WHEELS

In normal use, grinding wheels may become cracked, grooved, rounded at the edges, chipped, out of true or loaded with foreign material. Cracked wheels should be replaced IMMEDIATELY.

WHEEL REPLACEMENT

If you must replace a wheel, be sure to obtain one with a safe rated speed as high as the RPM marked on your grinders nameplate and with a 5/8” center hole. A 8” diameter wheel should be a maximum of 1” wide. Check new wheels for cracks and maintain the existing sequence of retaining hardware. Be sure the tool is unplugged before attempting repairs. Your bench grinder will accept most polishing and buffing wheels.

To replace the grinding wheel:

1. Turn the power switch to “OFF” and unplug the power cord from the power source.
2. Move eyeshields to “UP” position for easy access to the tool rests.
3. Remove the wheel cover by loosening the 3 screws holding the wheel cover to the bench grinder.
4. Using a small wooden wedge, place it between the abrasive wheel and the tool rest to prevent the wheel from turning.
5. With a 3/4” wrench, loosen the wheel nut in a clockwise direction for the left side and a counterclockwise direction for the right side.
6. Remove the outer flange and grinding wheel from the arbor shaft.
7. Replace with grinding wheels that are rated at a higher RPM rating than the bench grinder.

NOTE: DO NOT remove the label on the side of the abrasive wheel. Be sure the grinding wheel and both flanges are properly seated on the spindle shaft.

8. To install a new grinding wheel, reverse the removal procedure.

NOTE: DO NOT over tighten the lock nut as this may cause damage to the grinding wheel and may cause personal injury to the operator.

CLEAN your bench grinder only after the power switch is in the “OFF” position and unplugged from the power source. Turn the grinding wheels slowly and inspect for damaged or trapped debris and dust build up. Use a clean dry rag or brush to remove debris or dust build up.

NEVER use flammable materials to clean bench grinder.

PROTECT YOUR EYES.

The operation of any power tool can result in foreign objects being thrown into the eyes which can result in severe eye damage. Always wear eye protection during power tool operation.



NO LUBRICATION is required. Your bench grinder has sealed lubrication bearings in the motor housing.



WARNING: The use of any other accessories is not recommended and may result in serious injury.

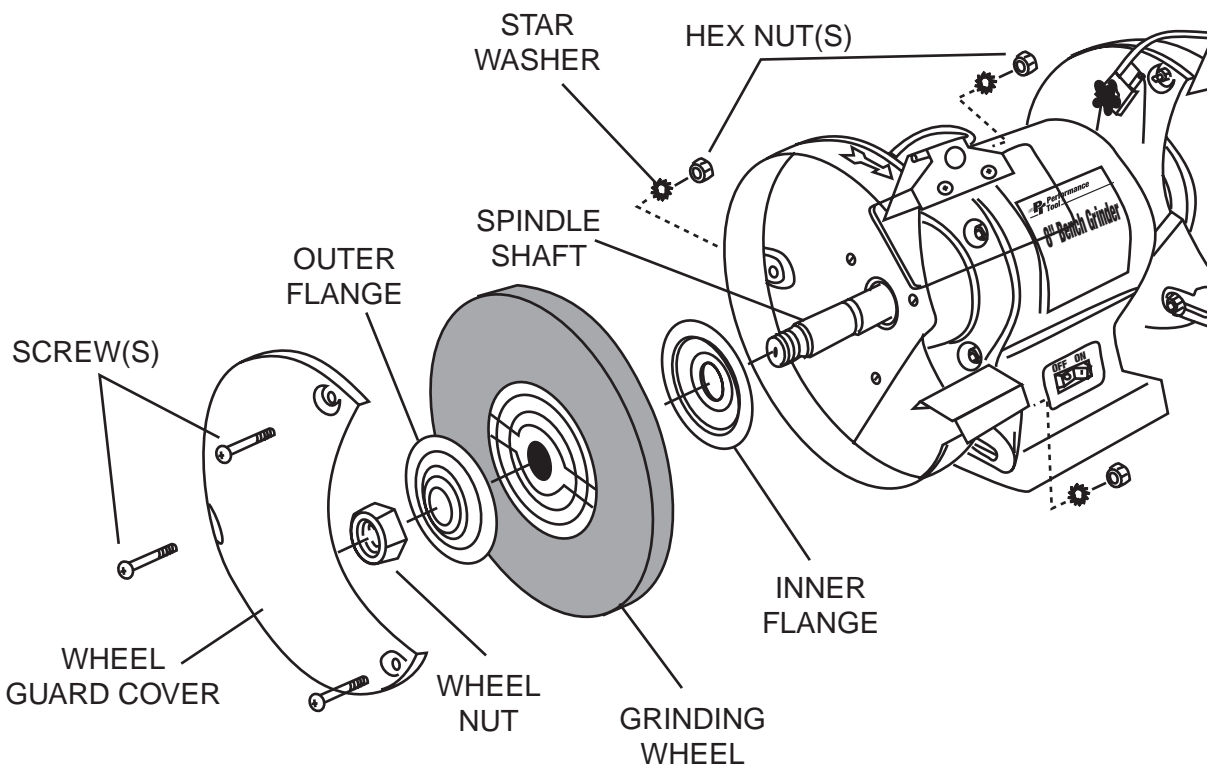

WARRANTY

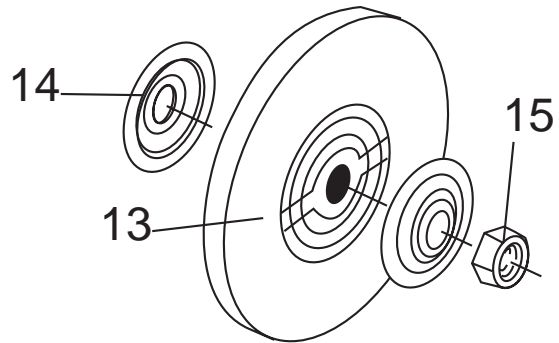
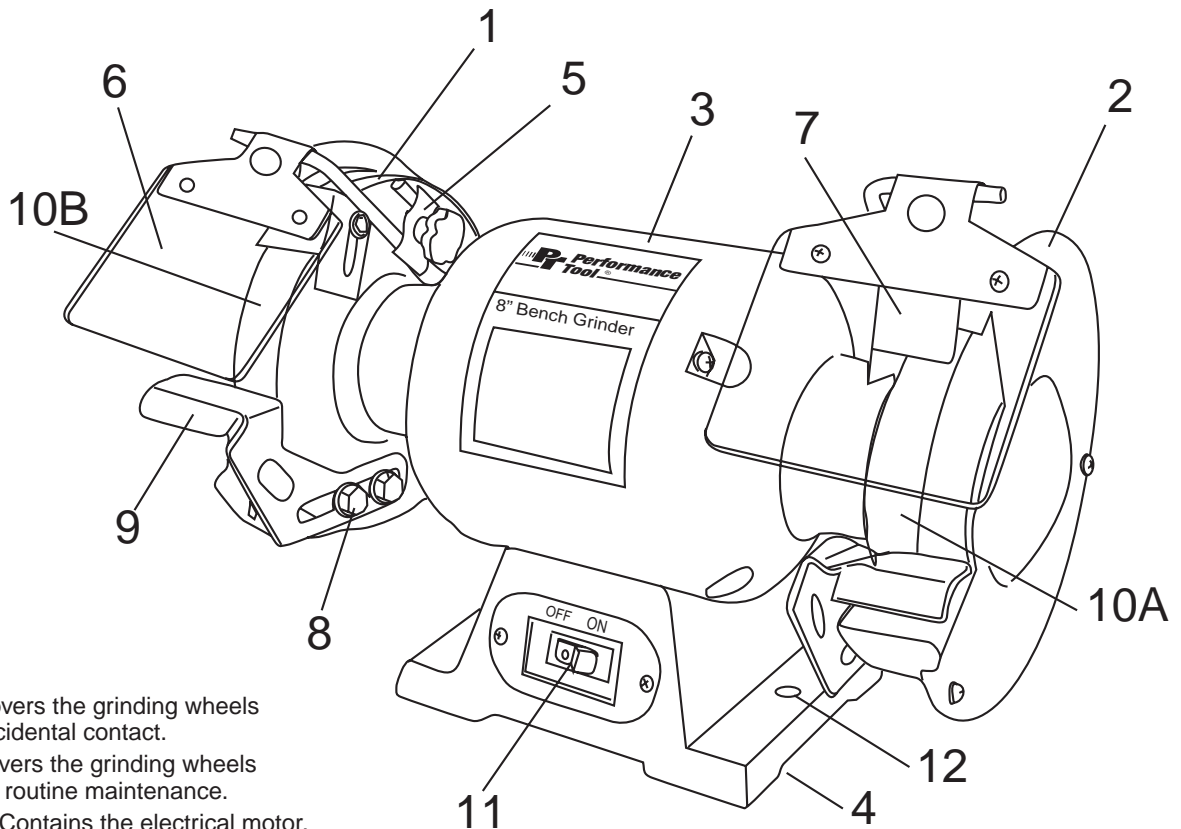

- 1. WHEEL GUARD** - Covers the grinding wheels and protects against accidental contact.
- 2. WHEEL COVER** - Covers the grinding wheels and provides access for routine maintenance.
- 3. MOTOR HOUSING** - Contains the electrical motor.
- 4. MOUNTING FEET** - Helps to minimize vibration of the grinder.
- 5. EYE SHIELD MOUNTS** - Supports the eyeshields.
- 6. EYE SHIELDS** - Protective see through shields prevent any loose debris from contacting the operator.
- 7. SPARK GUARDS** - Prevents hot sparks and debris from contacting the operator.
- 8. TOOL REST SUPPORT** - Lets the operator position the tool rest closer to the wheel as the wheel decreases in diameter due to wear.
- 9. TOOL RESTS** - Used to support the workpiece that is being ground.
- 10A. 8" GRINDING WHEEL 60 GRIT** - Used to remove light material from a workpiece.
- 10B. 8" GRINDING WHEEL 36 GRIT** - Used to remove heavy material from a workpiece.
- 11. ON / OFF SWITCH** - Used to turn "ON" and turn "OFF" the grinder.
- 12. MOUNTING PAD** - Used to secure grinder to a workbench or other suitable work surface.
- 13. GRINDING WHEEL IDENTIFICATION LABEL** - Provides information on the wheel size, grit and maximum rpm. Must be left on to distribute the load of tightening the lock nuts.

- 14. FLANGES** - Used to secure the grinding wheels to the grinder and distribute the load of the lock nuts.
- 15. LOCK NUT** - Used to secure the grinding wheels to the grinder.

1 YEAR LIMITED WARRANTY

PERFORMANCE TOOL extends only the following warranties, and only to original retail purchasers. These warranties give specific legal rights. Except where prohibited by local law, the law of the State of Washington governs all warranties and all exclusions and limitations of warranties and remedies. There may be other rights which vary from state to state.

PERFORMANCE TOOL warrants the product to be free from defects in materials and workmanship under normal use and service. A defective product may be returned for a free replacement within 1 year from the date of purchase, provided that product is returned to place of purchase immediately after discovery of defect. These warranties shall be valid only when a sales receipt showing the date of purchase accompanies the defective product being returned.

These warranties exclude blades, bits, punches, bulbs, fuses, grinding wheels, and other consumables which must be replaced under normal use and service. These warranties shall not apply to any product or part which is used for a purpose for which it is not designed, or which has been repaired or altered in any way so as to affect adversely its performance or reliability, nor shall these warranties apply to any product or part which has been subject to misuse, neglect, accident or wear and tear incident to normal use and service.

PERFORMANCE TOOL does not authorize any other person to make any warranty or to assume any liability in connection with its products.

Except for warranties of title and the limited express warranties set forth above, PERFORMANCE TOOL makes no express or implied warranties of any kind with respect to its products. In particular, PERFORMANCE TOOL makes no implied warranty of merchantability and no implied warranty of fitness for any particular purpose, except that for goods purchased primarily for personal, family or household use and not for commercial or business use, PERFORMANCE TOOL makes an implied warranty of merchantability (and, if otherwise applicable, an implied warranty of fitness for a particular purpose), but only for the particular qualities or characteristics, and for the duration, expressly warranted above. The laws on limitation of implied warranties may differ from state to state, so the above limitations may not apply in all cases.

PERFORMANCE TOOL shall not be liable for consequential, incidental or special damages resulting from or in any manner related to any product, or to the design, use, or any inability to use the product. The sole and exclusive remedy for a defective product or part shall be the repair, or replacement thereof as provided above. The laws on limitation of remedies or on consequential, incidental or special damages may vary from state to state, so the above limitations may not apply in all cases.