

# 4-1/2 IN. ANGLE GRINDER

Item Number W50044

## OWNER'S MANUAL



Performance Tool®

### ▲WARNING

*It is the owner and/or operators' responsibility to study all WARNINGS, operating, and maintenance instructions contained on the product label and instruction manual prior to operation of this product. The owner/operator shall retain product instructions for future reference.*

*The owner and/or operator are responsible for maintenance, maintaining all decals or warning labels and while in use, maintaining the unit in good working order. If the owner and/or operator are not fluent in English, the product warnings and instructions shall be read and discussed with the operators' native language by the purchaser/owner or his designee. Make sure that the operator comprehends its contents. Safety information shall be emphasized and understood prior to usage. The product shall be inspected per the operating instructions.*

*Users of this product must fully understand these instructions. Each person operating this product must also be of sound mind and body and must not be under the influence of any substance that might impair their vision, dexterity or judgment.*

*Protect yourself and others by observing all safety information.*

# SAFETY GUIDELINES / DEFINITIONS

This instruction manual is intended for your benefit. Please read and follow the safety, installation, maintenance and troubleshooting steps described within to ensure your safety and satisfaction. The contents of this instruction manual are based upon the latest product information available at the time of publication. The manufacturer reserves the right to make product changes at any time without notice.

**▲ WARNING:** Read and understand this entire instruction manual before attempting to assemble, install, operate or maintain this product. Failure to comply with the instructions may result in serious personal injury and/or property damage!

The following signal words are used to emphasize safety warnings that must be followed when using this product:

**▲ DANGER** Indicates an imminently hazardous situation that, if not avoided, WILL result in death or serious injury.

**▲ CAUTION** Indicates a potentially hazardous situation that, if not avoided, MAY result in minor or moderate injury.

**▲ WARNING** Indicates a potentially hazardous situation that, if not avoided, COULD result in death or serious injury.

**▲ NOTICE** Indicates important information, which if not followed, MAY cause damage to equipment.

# UNPACKING AND INSPECTION

After opening the carton, unpack your new product and related parts & accessories. Please inspect it carefully for any damage that may have occurred during transit. Please check it against the photograph on carton.

**▲ WARNING** DO NOT operate this product if damaged during shipment, handling or misuse. Do not operate the product until the parts have been replaced or the fault rectified. Failure to do so may result in serious personal injury or property damage. All damaged parts must be repaired or replaced as needed prior to operating this product. Check to see that all nuts, bolts and fittings are secure before putting this product into service.

Please have the serial number, model number, and date of purchase available for reference when calling.

# SPECIFICATIONS

Input .....	120V ~ 60Hz
Current .....	4.3 A
Rated power .....	500W
No load speed .....	12,000 RPM
Wheel diameter .....	4.5 in.
Arbor .....	5/8 in. - 11 UNC
Flange shoulder diameter .....	7/8 in.

**Specifications are subject to change without notice.**

# IMPORTANT SAFETY INFORMATION

**▲ WARNING**  
**READ, UNDERSTAND AND FOLLOW ALL INSTRUCTIONS AND WARNINGS BEFORE OPERATING THIS PRODUCT. FAILURE TO DO SO MAY RESULT IN FIRE, ELECTRICAL SHOCK, PERSONAL INJURY AND/OR PROPERTY DAMAGE AND WILL VOID WARRANTY.**

1. Always use common sense and pay particular attention to all the DANGER, WARNING, CAUTION and NOTICE statements of this manual. The safety instructions provided are not intended to cover all possible conditions and practices that may occur when operating, maintaining and cleaning power tools.
2. Observe work area conditions. Do not use machines or power tools in damp or wet locations. Don't expose to rain or snow. Keep work area well lit. Do not use electrically powered tools in the presence of flammable gases or liquids. Do not bring combustible materials near the tools. Power tools create sparks, which may ignite the dust or fumes. Do not immerse tool in liquids. Keep work area clean, well ventilated and well lit. Cluttered work areas invite accidents.
3. Use personal protective equipment. Wear ANSI approved safety goggles. Protective equipment such as dusk mask, non-skid safety shoes, hard hat, heavy duty work gloves or hearing protection used for appropriate conditions will reduce personal injuries.
4. Keep bystanders, children and visitors away while operating this product. Distractions can cause you to lose control.
5. Stay alert. Watch what you are doing, and use common sense when operating this tool. Do not use this product while tired or under the influence of drugs, alcohol, or medication. A moment of inattention while operating this product may result in serious personal injury. Keep proper footing and balance at all times. Do not reach over or across running machines, hoses, cords, etc.

# IMPORTANT SAFETY INFORMATION

6. Dress properly. Do not wear loose clothing or jewelry. Keep your hair, clothing and gloves away from moving parts. Loose clothes, jewelry or long hair can be caught in moving parts.
7. Work Safe. Operate tool a safe distance from yourself and others in the work area. Keep proper footing and balance at all times. Do not overreach, especially on ladders. Be certain ladders being used are sturdy, stable, on a firm surface and erected as safe working angles. Do not reach over or across running machines, hoses, cords, etc.
8. Inspect tool before every use; do not use if parts are loose or damaged.
9. Do not alter this product in any way.
10. Use the right tool for the job. Do not attempt to force a small tool or attachment to do the work of a larger industrial tool. Don't use a tool whose performance is not adequate for your work. Do not modify this tool and do not use this tool for a purpose for which it was not intended.
11. People with pacemakers should consult their physician(s) before use. Electromagnetic fields in close proximity to heart pacemaker could cause pacemaker interference or pacemaker failure. In addition, people with pacemakers should:
  - Avoid operating alone.
  - Do not use with power switch locked on.
  - Properly maintain and inspect to avoid electrical shock.
  - Any power cord must be properly grounded. Ground Fault Circuit Interrupter (GFCI) should also be implemented – it prevents sustained electrical shock.
12. Power tool plugs must match the outlet. Never modify the plug in any way. Do not use any adapter plugs with earthed (grounded) power tools. Unmodified plugs and matching outlets will reduce risk of electric shock. Do not use tool if plug is damaged.
13. Avoid body contact with earthed or grounded surfaces such as pipes, radiators, ranges and refrigerators. There is an increased risk of electric shock if your body is earthed or grounded.
14. Do not expose power tools to rain or wet conditions. Water entering a power tool will increase the risk of electric shock.
15. Do not abuse the cord. Never use the cord for carrying, pulling or unplugging the power tool. Keep cord away from heat, oil, sharp edges or moving parts. Damaged or entangled cords increase the risk of electric shock. Do not use tool if cord is damaged.
16. When operating a power tool outdoors, use only a 3-wire grounded cord with a wire size of 14 gauge or larger. We recommend they be listed by Underwriters Laboratories (UL) in the USA or (CSA) Canadian Standards Association in Canada and be suitable for outdoor use. Cords marked for outdoor use are also suitable for indoor use. Use of a cord suitable for outdoor use reduces the risk of electric shock.
17. If operating a power tool in a damp location is unavoidable, use a ground fault circuit interrupter (GFCI) protected supply. Use of a GFCI reduces the risk of electric shock.
18. Use power tool ONLY on adequately rated circuits to avoid overheating of electrical systems.
19. Prevent accidental starting. Ensure switch is in the "OFF" position before connecting to power source and/or battery pack, picking up or carrying the tool. Carrying power tools with your finger on the switch or energizing power tools that have the switch "ON" invites accidents.
20. Never let the power tool operate while unattended and unplug when not in use or before servicing.
21. Do not use the power tool if the switch does not turn it on and off. Any power tool that cannot be controlled with the switch is dangerous and must be repaired.
22. Never use this tool without the proper guard. The grinding wheel could shatter during use. Make sure the guard covers the side of the wheel facing you.
23. Never bounce the tool while grinding. This may crack the wheel.
24. Grinding metal will cause sparks! Keep them directed away from people and flammable materials. Always keep the guard positioned so that as much of the exposed disc as possible is pointing away from you.
25. Keep children and pregnant women away from the work area until the grinding is completed and the area has been cleaned up.
26. Always wear full eye, face and body protection. Wire bristles may break off and fly toward the user. Always wear ear protection when grinding in enclosed spaces. Noise level may be amplified in such locations and may cause permanent hearing loss.
27. Always wear an OSHA approved dusk mask or respirator when inside the work area. Replace the filter daily. NOTE: Not all dust masks offer protection from lead paint dust. Be sure to use the proper mask for the job.
28. Before connecting the tool to the power supply follow the safety instructions for installing the grinding or cutting wheels. Do not lock the wheels too tight or cracks may occur.
29. Only use grinding or cutting wheels with the correct bore size for the spindle of the grinder.
30. Use standard parts. Do not use coolant or water and do not use as a fixed grinder.
31. Do not start the tool when the grinding or cutting wheels are touching the work area.
32. Keep the power cord well away from the cutting area during use. Always position the cord so that

# IMPORTANT SAFETY INFORMATION

- it will not be caught in the workpiece when the grinder is in use.
33. Always have the guards in place and properly positioned when using grinding wheels or wire cup brushes.
  34. Secure the material being grinded. Never hold it in your hand or across your legs. Do not use your legs or feet to stabilize the workpiece. Unstable support can cause loss of control and could result in lacerations or injury.
  35. Use clamps or other practical ways to secure and support the workpiece to a stable platform.
  36. Always make sure no one, including the user, is in line with the tool when starting the motor.
  37. Always use both hands when operating the Angle Grinder.
  38. Always hold this tool by the insulated gripping surfaces. If this tool should accidentally cut across its own cord or hidden wiring, all exposed metal parts will become live and could seriously shock the user.
  39. When using the Angle Grinder, always maintain a firm grip on the tool. Keep your hands well away from the grinding wheel or brush. Never reach underneath the Angle Grinder while the sanding disk is in motion.
  40. When the Angle Grinder is in operation, keep hands away from the cutting or grinding area.
  41. Do not run the Angle Grinder while carrying it at your side. A moving grinding wheel or brush could cause lacerations or personal injury.
  42. The disc will not stop immediately when the Angle Grinder is turned off. Exercise caution.
  43. Do not set the Angle Grinder down after use until the grinding or cutting wheels have come to a complete stop.
  44. Keep the handle of the Angle Grinder dry, clean and free from oil and grease.
  45. Only use grinding and cutting wheels that are approved for a maximum speed of 11,000 RPM or greater.
  46. After replacing a wheel or brush, always let the tool run for one minute in a well-protected area. If the new accessory has an undetected flaw, it should break apart in less than a minute.
  47. Unplug Angle Grinder from power supply and place the switch in the locked or "OFF" position before making any assembly adjustments, changing accessories or performing any inspection, maintenance or cleaning procedures. Such preventive safety measures reduce the risk of starting the tool accidentally. Such preventive safety measures reduce the risk of starting the tool accidentally which could cause serious personal injury.
  48. Check for misalignment or binding of moving parts, breakage of parts, and any other condition that may affect the tool's operation. Many accidents are caused by poorly maintained tools.
  49. Maintain labels and nameplates on the Angle Grinder. These carry important information. If unreadable or missing, contact Performance Tool® for a replacement.
  50. Do not disassemble the angle grinder.
  51. Have your power tool serviced by a qualified repair person using only identical replacement parts. This will ensure that the safety of the power tool is maintained. Follow instructions in the Maintenance section of this manual. Use of unauthorized parts or failure to follow Maintenance Instructions may create a risk of shock or injury.
- ⚠ WARNING:** Some dust created by power sanding contains chemicals known to the State of California to cause cancer, birth defects or other reproductive harm. An example of this type of chemical is lead from lead based paints, Crystalline Silica from bricks and cement or other masonry, Arsenic and Chromium from chemically treated lumber. Your risk from these exposures varies, depending on how often you do this type of work. To reduce your exposure: work in a well ventilated area and work with approved safety equipment, such as dusk masks that are specially designed to filter out microscopic particles.
- ⚠ WARNING:** This product and its packaging contain a chemical known to the State of California to cause cancer, birth defects, or other reproductive harm.

# GROUNDING

**▲WARNING:** Improperly connecting the grounding wire can result in the risk of electric shock. Check with a qualified electrician if you are in doubt as to whether the outlet is properly grounded. Do not modify the power cord plug provided with the tool. Never remove the grounding prong from the plug. Do not use the tool if the power cord or plug is damaged. If damaged, have it repaired by a service facility before use. If the plug will not fit the outlet, have a proper outlet installed by a qualified electrician.

## GROUNDED TOOLS: TOOLS WITH THREE PRONG PLUGS

1. Tools marked with "Grounding Required" have a three wire cord and three prong grounding plug. The plug must be connected to a properly grounded outlet. If the tool should electrically malfunction or break down, grounding provides a low resistance path to carry electricity away from the user, reducing the risk of electric shock. (See Figure A.)
2. The grounding prong in the plug is connected through the green wire inside the cord to the grounding system in the tool. The green wire in the cord must be the only wire connected to the tool's grounding system and must never be attached to an electrically "live" terminal. (See Figure A.)
3. Your tool must be plugged into an appropriate outlet, properly installed and

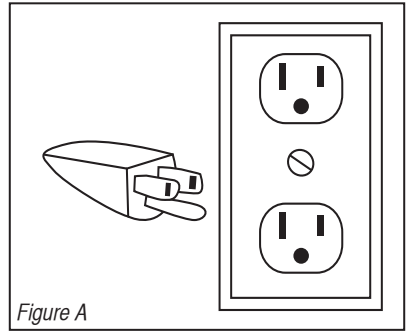

Figure A

grounded in accordance with all codes and ordinances. The plug and outlet should look like those in the following illustration. (See Figure A)

## DOUBLE INSULATED TOOLS: TOOLS WITH TWO PRONG PLUGS

1. Tools marked "Double Insulated" do not require grounding. They have a special double insulation system which satisfies OSHA requirements and complies with the applicable standards of Underwriters Laboratories, Inc., the Canadian Standard Association, and the National Electrical Code. (See Figure B.)
2. Double insulated tools may be used in either of the 120 volt outlets shown in the following illustration. (See Figure B.)

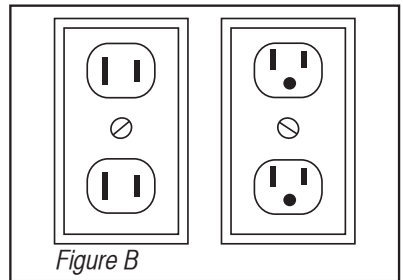

Figure B

## EXTENSION CORDS

Use only accessories that are recommended by the manufacturer for your model. Accessories that may be suitable for one tool may become hazardous when used on another tool.

Always attach grounded (3-prong) extension cords to grounded (3-hole) outlets. If you must use an extension cord, be sure

that the gauge is large enough to carry the amount of current necessary for your power tool. If not, your tool may experience a loss of power, excessive voltage drop or overheating. The smaller the gauge number, the heavier the cord (see table on next page).





# GROUNDING

## RECOMMENDED SIZES OF EXTENSION CORDS FOR 120 VOLT AC 60 HZ TOOLS

CURRENT RATINGS IN AMPS		CONDUCTOR SIZE IN A.W.G.			
MORE THAN	LESS THAN	10 ft.	25 ft.	50 ft.	100 ft.
3	6	18	18	18	18
6	8	18	18	18	16
8	10	18	18	18	14
10	12	16	16	14	14
12	16	14	14	12	NOT RECOMMENDED

## SYMBOL DEFINITIONS

**IMPORTANT:** Some of the following symbols may be used on your tool. Please study them and learn their meaning. Proper interpretation of these symbols will allow you to operate the tool better and safer.

Symbol	Name	Explanation
V	Volts	Voltage (Potential)
A	Amperes	Current
Hz	Hertz	Frequency (Cycles per Second)
W	Watt	Power
Kg	Kilograms	Weight
	Alternating Current	Type of Current
	Direct Current	Type of Current
	Alternating or Direct Current	Type of Current
	Earthing Terminal	Grounding Terminal
	Class II Construction	Denotes Double Insulation
min	Minutes	Time
s	Seconds	Time
∅	Diameter	Size of Drill Bits, Grinding Wheels, etc.
$n_0$	No load speed	No-load Rotational Speed
.../min	Revolutions per Minute	Revolutions, Surface Speed, Strokes, etc. per Minute
1,2,3,...	Ring Selector Settings	Speed, Torque or Position Settings

# CONTROLS AND COMPONENTS

1. ON/OFF Switch with lock-on feature
2. Protective Guard
3. Grinding Wheel
4. Spindle Lock Button
5. Side Handle
6. Power Cord



# ASSEMBLY

## ATTACHING AUXILIARY HANDLE

This tool comes with an auxiliary handle which can be attached to different sides of the Angle Grinder, depending on the preference of the operator. This handle is necessary to maintain complete control of the tool and should be used at all times. Make sure this handle is always fastened securely.

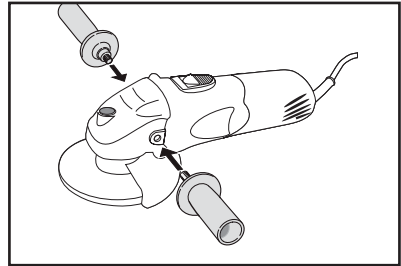

## ATTACHING WHEEL GUARD

**▲ CAUTION** Never brush or grind without the guard in place. Brushes are considered to be grinding wheels and must also be used with guards.

1. Always unplug the tool before attempting to change the guard or accessories.
2. Set the Angle Grinder on a flat surface with the spindle facing up.
3. Place the guard clamp over spindle head assemble.
4. Rotate guard to desired location.
5. Tighten clamp screw with a Phillips screwdriver.
6. Make sure that the guard is securely tightened in place.

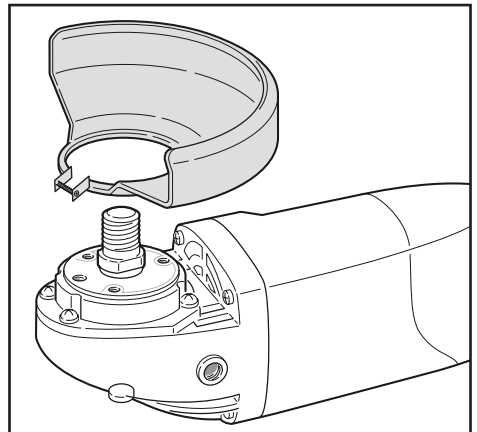

7. To remove guard, loosen clamp screw and lift guard up while slightly rotating.

# ASSEMBLY

## ATTACHING GRINDING WHEEL OR CUTTING DISC

1. Unplug the grinder.
2. Turn the tool upside down.
3. Place the inner flange on the spindle so that it matches with the flats on the shaft.
4. Fit the disc over the boss on the inner flange.
5. Screw the wheel-retaining nut down over the disc. Depending on the disc thickness, the boss on the outer flange nut can face down or up.
6. Fit the two prongs of the wrench into the holes in the outer flange nut.
7. Depress the spindle lock button and firmly tighten the nut with the wrench.
8. Turn the wheel by hand, checking for any obstruction.

## ATTACHING WHEELS WITH DEPRESSED CENTERS

**▲WARNING** Always check the tool warning label for the recommended speed rating on accessories. Never run a wheel or brush over the rated speed. Accessories exceeding the recommended speed may fly apart and cause serious personal injury.

**NOTE** Hubbed wheels do not require mounting flanges.

1. Place the inner flange over the spindle making sure the fit is tight.
2. Place the grinding or cutting disc on the top of the inner flange ensuring the bore fits into the step of the flange.
3. Mount the concave recess side of the outer flange nut over the spindle.

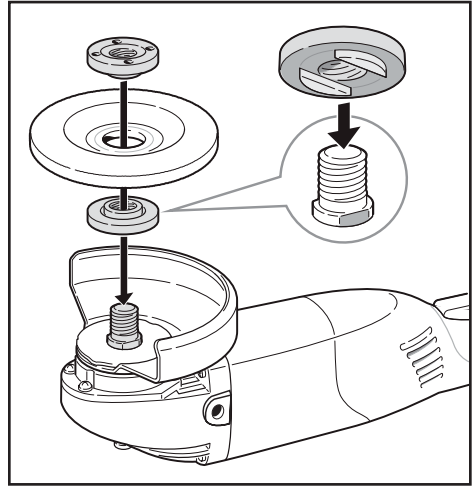

# OPERATION

**▲WARNING** READ ALL WARNINGS IN THIS MANUAL BEFORE OPERATING THIS TOOL.

## USING THE ON/OFF SWITCH

**▲WARNING** Never switch the Angle Grinder “ON” or “OFF” while under load conditions.

1. When starting hold the Angle Grinder firmly with both hands. One hand on the rear handle or the motor housing and the other hand on the side handle.
2. To turn the Angle Grinder “ON” without locking it, push the switch up without putting pressure on the switch. When pressure is released, the switch snaps to the “OFF” position.
4. To lock the switch “ON”, press the switch button up while pressing down.

5. To unlock the switch, simply press and release the back (grooved) part of the switch. Switch is spring loaded and will snap back automatically.

**▲CAUTION** Always allow the Angle Grinder to come up to full speed before touching any surface. Always take the tool away from the workpiece before turning the tool “OFF”. Let the tool come to a complete stop before setting it down. This tool operates best under light pressure. Exerting heavy pressure will not speed up the work and may cause damage to the motor.



# OPERATION

## USING THE ANGLE GRINDER

This angle grinder is designed to accept only 4-1/2" abrasive discs with a 5/8" bore. Check to ensure that any discs used on this machine are rated for the 12,000 /min speed of this grinder. Check also for any damage to an abrasive disc before installing. Any disc that is cracked, has been dropped, or subjected to other damage due to temperature extremes or solvents should be discarded. A damaged disc can fly apart in use and may cause serious injury to the operator or bystanders

1. Plug in the tool.
2. Hold the tool firmly with one hand on the side handle and the other gripping the housing. Check to make sure the abrasive disc is not obstructed. Slide the switch on the Top of the machine forward with your thumb. Switching the tool on or off under load will damage the switch.

**NOTE** For best tool control, material removal and minimal loading, keep the angle between the disc and the work surface at approximately 30° when grinding and 10°-15° when sanding.

3. To turn the tool off, slide the switch back.

- ▲ WARNING:** Turn off your tool at once, unplug and inspect it for serious problems if:
- Moving parts get stuck
  - Speed drops to an abnormally low level
  - The motor housing gets hot
  - Sparks or odors emit from the casing

## CARE & MAINTENANCE

**▲ WARNING** Always turn power switch to "OFF" position and unplug power cord from electrical outlet before attempting cleaning or maintenance.

**▲ NOTICE** This power tool is lubricated before it leaves the factory. This lubrication should last for the life of the tool. No further lubrication is required.

The armature and motor are the heart of the power tool. Exercise care to ensure they do not become damaged or effected by oil or water.

Inspect the carbon brushes regularly and replace them when they are worn. (about 1/3 of the way up)

Regularly inspect all mountings and screws and ensure they are properly tightened. Failure to do so may result in serious damage.

Consult an authorized maintenance service agent in event of damage.

Clean and dust the Angle Grinder after each use. Use compressed air to blow out any

accumulated dust or grit. Tiny particles from metal grinding often accumulate inside your tool and could create an electrical shock hazard.

Never use solvents or harsh chemicals. Use only mild soap and a damp cloth to clean the tool.

Never let any liquid get inside the casing. Never immerse any part of the tool in a liquid. Always keep the ventilation openings clear.

Regularly clean the ventilation slots in your tool using a soft brush or dry cloth.

1. Do not cover exhaust vents when the Angle Grinder is in use. This may cause damage to the motor and reduce efficiency.
2. Guide back and forth over the work piece in a steady motion.
3. When cutting avoid tilting the Angle Grinder in the cutting plane. Ensure the cutting wheel has a clean cutting edge.
4. To cut hard stone a diamond cutting wheel is recommended.
5. Do not use cutting wheel for rough grinding.

## 1 YEAR LIMITED WARRANTY

PERFORMANCE TOOL® extends only the following warranties, and only to original retail purchasers. These warranties give specific legal rights. Except where prohibited by local law, the law of the State of Washington governs all warranties and all exclusions and limitations of warranties and remedies. There may be other rights which vary from state to state.

PERFORMANCE TOOL® warrants the product to be free from defects in materials and workmanship under normal use and service. A defective product may be returned for a free replacement within 90 days from the date of purchase, provided that product is returned to place of purchase immediately after discovery of defect. After 90 days and up to one year from date of purchase, PERFORMANCE TOOL® will replace at no charge any parts which our examination shall disclose to be defective and under warranty.

These warranties exclude blades, bits, punches, dies, bulbs, fuses, hoses, and other consumables which must be replaced under normal use and service. These warranties shall not apply to any product or part which is used for a purpose for which it is not designed, or which has been repaired or altered in any way so as to affect adversely its performance or reliability, nor shall these warranties apply to any product or part which has been subject to misuse, neglect, accident or wear and tear incident to normal use and service.

PERFORMANCE TOOL® does not authorize any other person to make any warranty or to assume any liability in connection with its products.

Except for warranties of title and the limited express warranties set forth above, PERFORMANCE TOOL® makes no express or implied warranties of any kind with respect to its products. In particular, PERFORMANCE TOOL® makes no implied warranty of merchantability and no implied warranty of fitness for any particular purpose, except that for goods purchased primarily for personal, family or household use and not for commercial or business use, PERFORMANCE TOOL® makes an implied warranty of merchantability (and, if otherwise applicable, an implied warranty of fitness for a particular purpose), but only for the particular qualities or characteristics, and for the duration, expressly warranted above. The laws on limitation of implied warranties may differ from state to state, so the above limitations may not apply in all cases.

PERFORMANCE TOOL® shall not be liable for consequential, incidental or special damages resulting from or in any manner related to any product, or to the design, use, or any inability to use the product. The sole and exclusive remedy for a defective product or part shall be the repair, or replacement thereof as provided above. The laws on limitation of remedies or on consequential, incidental or special damages may vary from state to state, so the above limitations may not apply in all cases.