

# 6" Dual Action Air Sander

Stock Number M641

## OWNER'S MANUAL



### WARNING!

READ, UNDERSTAND AND FOLLOW ALL INSTRUCTIONS AND WARNINGS BEFORE OPERATING THIS TOOL. FAILURE TO DO SO MAY RESULT IN PERSONAL INJURY AND/OR PROPERTY DAMAGE AND WILL VOID WARRANTY.

**Performance**  
**Tool**

## SPECIFICATIONS

Pad size.....	6 in.
Sanding surface.....	28-1/4 sq. in.
Spindle/thread size.....	5/16 in. / 24 UNF
Orbital stroke.....	5/16 in.
Air pressure.....	90 P.S.I.
Average air consumption.....	5 C.F.M.
Free speed.....	10,000 R.P.M.
Air inlet.....	1/4 in. N.P.T.
Recommended hose size.....	3/8 in. I.D.
Length.....	9.1 in.
Weight.....	3.8 lbs.

Specifications are subject to change without notice

## IMPORTANT SAFETY INFORMATION

### WARNING!

READ, UNDERSTAND AND FOLLOW ALL INSTRUCTIONS AND WARNINGS BEFORE OPERATING THIS TOOL. FAILURE TO DO SO MAY RESULT IN PERSONAL INJURY AND/OR PROPERTY DAMAGE AND WILL VOID WARRANTY.

1. Use only paper sanding disks with the proper adhesive. Read, understand and follow all adhesive manufacturers' directions. **DO NOT USE CLOTH BACKED SANDING DISKS WITH THIS TOOL.**
2. Make sure sanding pad RPM rating matches Free Speed rating of this tool.
3. Wear a dust mask while operating this tool. Read, follow and understand manufacturers instructions on paint, primer, paint preps, glazing, body filler, etc. for additional respirator and ventilating requirements.
4. Always use approved eye and ear protection when using air powered tools. If raising dust/debris, wear a suitable mask. Do not wear loose clothing or jewelry.
5. Always operate tool a safe distance from yourself and others in the work area. Keep footing and balance at all times.
6. Make sure work piece is secure to allow safe operation of the tool with both hands. Do not hold the work piece in your hand, lap or against any part of your body.
7. Make sure trigger is in the "off" position before connecting or disconnecting the tool from air source. Disconnect tool from air source before changing accessories, performing service and when not in use.

## IMPORTANT SAFETY INFORMATION

8. Follow air source manufacturer's directions for connection of regulators, filters and other accessories to air source. Do not install quick couplers directly at tool air inlet. This causes inlet failure due to excess weight and vibration. Use a whip hose between tool and quick couplers.
9. **DO NOT OVERLOAD!** Do not force tool. Match tool capacity to work load requirement. Use tool within its rated capacity and only for its designated purpose. Overloading air tools will cause premature wear and/or permanent damage of internal and external drive parts and will void warranty.
10. Inspect hoses and fittings for wear and damage prior to using tool. Do not carry or drag tool by the air hose. Keep air hose free from obstruction, twisting and binding.

## OPERATION

1. Regulate pad speed with air regulator knob.
2. Start the sander off the sanding surface. Set the sander on the surface gently and evenly and start the work. Let the sander do the work. The weight of the sander will provide efficient sanding. Applying pressure to the sander will only slow the speed of the pad and reduce sanding efficiency. This will also overload the motor and cause premature wear of the tool and void the warranty.
3. Work the sander back and forth in a wide, overlapping motion. Lift the sander off the surface before releasing the trigger.
4. Start with a paper grit coarse enough to remove high spots and rough areas. Continue using progressively finer grit to attain desired finish.

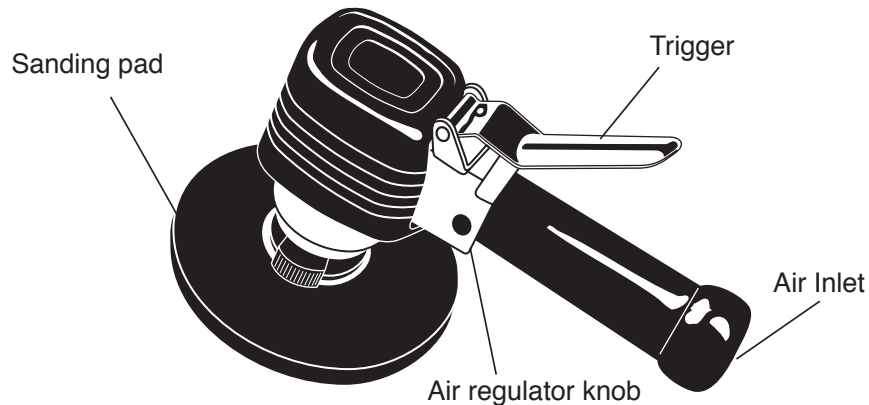

## AIR SOURCE

Clean air of correct air pressure is recommended for the power supply for this tool. A maximum of 90 PSI at the tool is recommended for most air tools of this class. Check specifications section for recommended pressure. (Depending on length of air hose and other circumstances, air pressure at compressor may need to be increased to 100 PSI to ensure 90 PSI at the tool.) Water in the air hose and compressor tank contributes to reduced performance and damage of the air tool. Drain the air tank and filters before each use and as necessary to keep the air supply dry. Hose length over 25' causes loss in line pressure. Increase hose I.D. or increase compressor pressure to compensate for the pressure loss. Use an in-line pressure regulator with gauge if air inlet pressure is critical.

## LUBRICATION & MAINTENANCE

**Oil tool before each use.** 4 to 5 drops of a good grade Air Tool Oil placed in the air inlet is sufficient. Use proper air pressure and CFM rating listed for this tool.

**Drain water from hoses and compressor tank.** Water in the air supply line will cause gumming and loss of power. Clean the air filter on the supply line and flush the tool with gum solvent or a 50/50 mix of air tool oil and kerosene. It may be necessary to disassemble the tool to properly clean and re-lubricate.



Yes

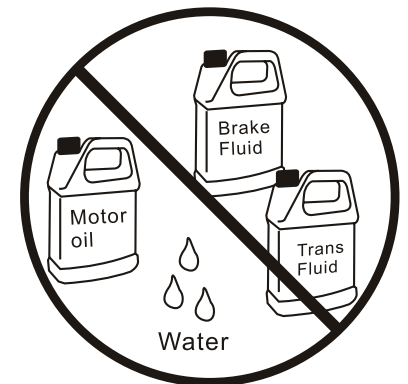

No

## PARTS LIST

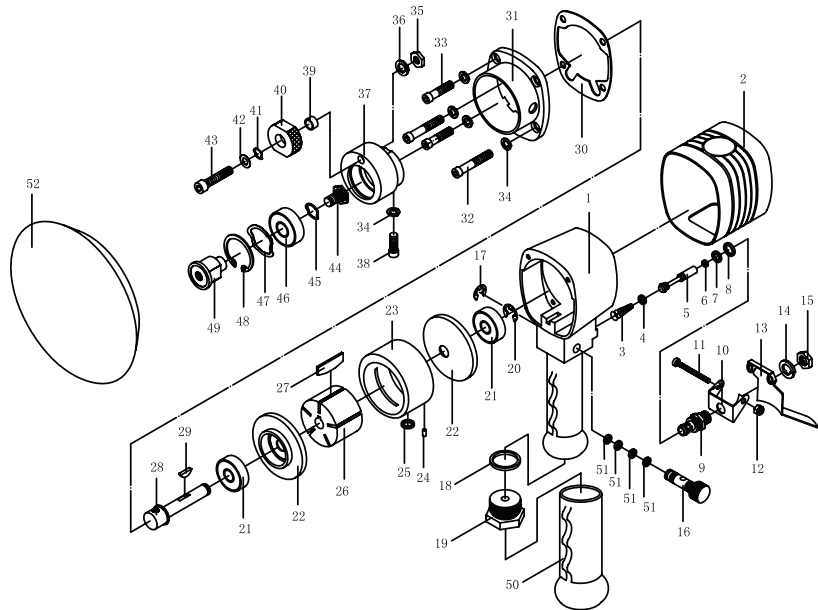

No.	DESCRIPTION	QTY	No.	DESCRIPTION	QTY
1.	Housing	1	27.	Rotor Blade	5
2.	Rubber	1	28.	Work Spindle	1
3.	Spring	1	29.	Key	1
4.	O-Ring	1	30.	Rear Gasket	1
5.	Valve Stem	1	31.	Rear Cover	1
6.	O-Ring	1	32.	Screw	2
7.	O-Ring	1	33.	Screw	2
8.	O-Ring	1	34.	Washer	5
9.	Valve Body	1	35.	Cap	1
10.	Bracket	1	36.	Washer	1
11.	Trigger Screw	1	37.	Balancer	1
12.	Screw	1	38.	Screw	1
13.	Trigger	1	39.	Bushing	1
14.	Washer	1	40.	Spindle Lock	1
15.	Cap	1	41.	Washer	1
16.	Air Regulator	1	42.	Washer	1
17.	Retainer Ring	1	43.	Screw	1
18.	O-Ring	1	44.	Screw	1
19.	Air Inlet	1	45.	Washer	1
20.	Retainer Ring	1	46.	Bearing	1
21.	Bearing	2	47.	Washer	1
22.	End Plate	2	48.	Retainer Ring	1
23.	Cylinder	1	49.	Drive Spindle	1
24.	Pin	1	50.	Rubber	1
25.	O-Ring	1	51.	O-Ring	4
26.	Rotor	1	52.	Pad	1

## TROUBLESHOOTING

### INSUFFICIENT POWER:

Probable Cause	Solution
Dirty or clogged air passages.....	Flush and lubricate tool, drain air tank and supply line
Insufficient air supply.....	Increase line pressure, Make sure compressor matches tool's air pressure and consumption needs
Air leakage.....	Use PTFE tape at all fittings and joints. Check tool for worn or damaged O-rings & seals.
Worn/damaged wear & tear parts...	Replace as necessary.
Tool matching .....	Be sure you are using a tool suited for the torque requirements of the job at hand.

### LIMITED WARRANTY

PERFORMANCE TOOL® extends only the following warranties, and only to original retail purchasers. These warranties give specific legal rights. Except where prohibited by local law, the law of the State of Washington governs all warranties and all exclusions and limitations of warranties and remedies. There may be other rights which vary from state to state.

PERFORMANCE TOOL® warrants the product to be free from defects in materials and workmanship under normal use and service. A defective product may be returned for a free replacement within 90 days from the date of purchase, provided that product is returned to place of purchase immediately after discovery of defect. After 90 days and up to one year from date of purchase, PERFORMANCE TOOL® will replace at no charge any parts which our examination shall disclose to be defective and under warranty.

These warranties exclude blades, bits, punches, dies, bulbs, fuses, hoses, and other consumables which must be replaced under normal use and service. These warranties shall not apply to any product or part which is used for a purpose for which it is not designed, or which has been repaired or altered in any way so as to affect adversely its performance or reliability, nor shall these warranties apply to any product or part which has been subject to misuse, neglect, accident or wear and tear incident to normal use and service.

PERFORMANCE TOOL® does not authorize any other person to make any warranty or to assume any liability in connection with its products.

Except for warranties of title and the limited express warranties set forth above, PERFORMANCE TOOL® makes no express or implied warranties of any kind with respect to its products. In particular, PERFORMANCE TOOL® makes no implied warranty of merchantability and no implied warranty of fitness for any particular purpose, except that for goods purchased primarily for personal, family or household use and not for commercial or business use, PERFORMANCE TOOL® makes an implied warranty of merchantability (and, if otherwise applicable, an implied warranty of fitness for a particular purpose), but only for the particular qualities or characteristics, and for the duration, expressly warranted above.

The laws on limitation of implied warranties may differ from state to state, so the above limitations may not apply in all cases.

PERFORMANCE TOOL® shall not be liable for consequential, incidental or special damages resulting from or in any manner related to any product, or to the design, use, or any inability to use the product. The sole and exclusive remedy for a defective product or part shall be the repair, or replacement thereof as provided above. The laws on limitation of remedies or on consequential, incidental or special damages may vary from state to state, so the above limitations may not apply in all cases.