

1/2 IN. DR. STUBBY IMPACT WRENCH

Stock Number M632

OWNER'S MANUAL



Performance Tool®

WARNING!

READ, UNDERSTAND AND FOLLOW ALL INSTRUCTIONS AND WARNINGS BEFORE OPERATING THIS TOOL. FAILURE TO DO SO MAY RESULT IN PERSONAL INJURY AND/OR PROPERTY DAMAGE AND WILL VOID WARRANTY.

PT®

Performance Tool

SPECIFICATIONS

Drive Size	1/2 in.	Average Air Consumption . . .	7 C.F.M.
Max Reverse Torque.	767 ft. lbs.	Free Speed	12,000 RPM
Max Forward Torque	667 ft. lbs.	Air inlet (N.P.T.)	1/4 in.
Working Torque	50-580 ft. lbs.	Hose size (I.D.)	3/8 in.
Air Pressure	90 p.s.i.	Weight	3.25 lbs.

Specifications are subject to change without notice.

IMPORTANT SAFETY INFORMATION

WARNING!

READ, UNDERSTAND AND FOLLOW ALL INSTRUCTIONS AND WARNINGS BEFORE OPERATING THIS TOOL. FAILURE TO DO SO MAY RESULT IN PERSONAL INJURY AND/OR PROPERTY DAMAGE AND WILL VOID WARRANTY.

1. Always work in a clean, dry, well-ventilated area free of combustible materials. Never operate the tool near flammable substances such as gasoline, naphtha, cleaning solvent, etc.
2. Dress properly. Do not wear loose clothing. Tie up or cover long hair, remove any jewelry, necklaces, etc., which might become caught by the tool.
3. Keep the work area well lit and free of clutter. Slips, trips and falls are major causes of workplace injury. Be aware of excess air hose left on your walking way or on the working surface.
4. Ensure that there are no electrical cables, gas pipes, etc., which can cause a hazard if damaged by use of the tool.
5. Keep visitors a safe distance from the work area. Keep children away.
6. Stay alert and use common sense. Watch what you are doing. Do not operate the tool when you are tired or under the influence of alcohol, drugs or medication.
7. Do not overreach. Keep proper footing and balance at all times.
8. Always wear eye protectors which provides protection from flying particles from the front and side when using the tool. Ear protectors should also be worn.
9. Never use oxygen, carbon dioxide, combustible gases or any other type of bottled gases as a power source for this tool.
10. Always verify prior to using this tool that the air source has been adjusted to the rated air pressure range. Never connect to an air source that is capable of exceeding 200psi.
11. Do not connect the air supply hose to the tool with your finger on the trigger.
12. Do not exceed the maximum working pressure 90psi/6.3bar for the tool. Excessive pressure will reduce the tool life and/or might cause a hazardous situation.
13. Never leave the operating tool unattended. Disconnect the air hose when the tool is not in use.
14. Keep the air supply hose away from heat, oil and sharp edges.
15. Check the air supply hose for wear and/or leaks before each use. Make sure that all connections are tight and secure.
16. Do not use the tool for any other than its intended use.
17. Do not carry out any alternations and/or modifications to the tool.
18. Always disconnect the tool from air supply before replacing any accessories, performing any repair and maintenance, moving to another work area, or passing the tool to another person.
19. Never use the tool if it is defective, damaged, or operating abnormally.
20. Check for misalignment or binding of moving parts, breakage of parts and any other condition that affects the tool operation. If damaged, have the tool serviced before using.

IMPORTANT SAFETY INFORMATION CONT.

21. Keep working parts of the tool away from hands and body.
22. Do not carry the tool by the air hose.
23. Do not apply excessive force of any kind to the tool. Let the tool perform the work at the rate as it was designed.
24. Do not remove any labels on the tool. Replace if they become obscured or damaged.
25. Always maintain the tool with care. Keep it clean for the best and safest performance.
26. It is not recommended that quick change couplings should be located directly at the air inlet, as they add weight and could fail due to vibration.
27. This tool vibrates with use. Continuous operation of this tool might be harmful to your hands or arms. Stop using the tool if discomfort, a tingling feeling or pain occurs. Resume work after recovery. Seek medical advice if a serious symptom occurs.

AIR IMPACT WRENCH SAFETY

1. Always use the impact wrench in the manner and for the functions described in this manual.
2. Always ensure the wrench is not moving and disconnected from the air supply when changing sockets etc. Only use impact sockets. Do not use standard sockets.
3. Always finish tightening wheel nuts or engine parts with a torque wrench or suitable spanner to the correct torque as recommended by the vehicle manufacturer.
4. Always avoid excessive use of the impact wrench. When tightening a nut or bolt, never allow the wrench to impact more than 8 times. This is to avoid over-tightening. 3 to 4 impacts is normally sufficient.
5. Always ensure that the socket is correctly installed onto the tool anvil before starting the tool.
6. Due to the possible presence of asbestos dust from brake linings, always wear suitable respiratory protection.
7. Never carry the impact wrench by the air supply hose.
8. Always disconnect the tool from the air supply when changing impact sockets or when the wrench is not required for immediate use in order to avoid accidental start.
9. Hold the tool correctly. Always use both hands to control the impact wrench.
10. Always ensure that the wrench has come to a complete stop before putting it down after use.
11. If necessary, use clamps or proper devices to securely fix the workpiece when installing/tightening or removing/loosening threaded fasteners on the workpiece.
12. For overhead work, wear a safety helmet.
13. Do not discard the safety instructions, give them to the operator.
14. Always store this product in a dry and safe place out of reach of children or untrained operators.

▲ WARNING: Repetitive motions or exposure to vibration may be harmful to your hands and arms.

▲ WARNING: The warnings, cautions, and instructions discussed in this instruction manual cannot cover all possible conditions and situations that may occur. It must be understood by the operator that common sense and caution are factors which cannot be built into this product, but must be supplied by the operator. Read and understand all of the instructions provided in the instruction manual of this product, as well as, any other tool (s) used with this product.

AIR SOURCE

1. Use only clean, dry, regulated compressed air as the power source.
2. Air compressors used with the tool must comply with the appropriate European Community Safety Directives.
3. Make sure that the air compressor being used for the tool operation supplies the correct output (CFM).
4. Have the tool in "off" position when connecting the tool to the air supply.
5. Use normal 90psi working pressure for the tool. High pressure and unclean air will shorten the tool life due to the faster wear and also may create a safety hazard.
6. Drain water from the air compressor tank daily, as well as any condensation in the air lines. Water in the air line may enter the tool and cause damage to the tool mechanisms at operation.
7. Clean the tool air inlet screen filter for blockage weekly. Clean if necessary.
8. Usually a 3/8" (inner diameter) air hose is recommended for air supply and airflow to get the optimum performance of tool.
9. A long air hose (usually over 8 meters) may cause up to 15psi drop in pressure, so you need to set the output pressure of the air compressor higher to maintain the required working pressure at the tool.
10. Use proper hoses and fittings. We do not suggest connecting quick change couplings directly to the tool since they may cause failure due to tool vibration at operation. Instead, add a lead hose and connect coupling between air supply and hose whip.
11. Check hoses for wear before each use. Make certain that all connections are in security.

ASSEMBLY

1. Remove the air inlet protective cap from the air inlet.
2. Mount a male plug by hand into the air inlet.
NOTE: Use thread sealant tape on the male plug and tighten it with a wrench for airtight connection. Do not overtighten.
3. Place 2 - 3 drops of air tool oil into the male plug before each use.
4. Choose the correct impact socket (not provided) as needed and mount it onto the anvil.
5. If necessary, use an extension bar (not provided) and then mount impact socket onto the bar.
6. Connect air supply hose to the male plug.
7. Set the working pressure at 90psi/6.3bar for best tool performance.
NOTE: Working pressure refers to the air line pressure set to tool when tool is under working conditions.

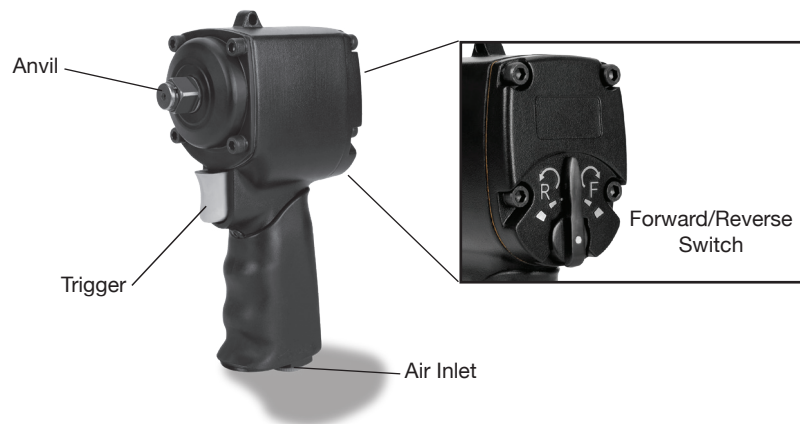

OPERATION

1. How to install/tighten threaded fasteners.
Turn the switch forward and have the arrow on the switch pointing at either of the three dots on the back housing as shown. Press the variable speed trigger to apply the needed force for your application. The tool anvil runs clockwise.
2. How to remove/loosen threaded fasteners.
Turn the switch backward and have the arrow on the switch pointing at the large dot on the back housing as shown in the picture above. Press the trigger. The tool anvil runs counterclockwise.
NOTE: This tool features a power regulator valve. Turn the switch slowly forward until desired output is achieved. The three dashes (small, medium, large) do not denote a specific power output but are only for reference. "Setting 1" (small dash) is the least amount of power, which is suitable for just mounting threaded fasteners on workpiece while "Setting 3" (large dash) is the greatest amount of power, which is for tightening threaded fasteners on workpiece. This tool operates in maximum power in reverse, which releases threaded fasteners from workpiece with ease. Choose the correct speed level needed on workpiece when mounting or releasing threaded fasteners.

NOTE: Make sure that this tool has the correct torque to tighten/release threaded fasteners. The torque applied to threaded fasteners can be found in their instructions or manuals. Overtightening of your fasteners will strip threads or break bolts resulting in costly or time consuming repairs.



CARE & MAINTENANCE

An in-line oiler is recommended to be installed on air supply line as it increases tool life and keeps the tool in sustained operation. The in-line oiler should be regularly checked and filled with air-tool oil. Proper adjustment of the in-line oiler is performed by placing a sheet of paper next to the tool's exhaust ports and holding the throttle open approximately 30 seconds. The in-line oiler is properly set when a light stain of oil collects on the paper. Excessive amounts of oil should be avoided.

In the event that it becomes necessary to store the tool for an extended period of time, it should receive a generous amount of lubrication at that time. The tool should be run for approximately 30 seconds to ensure oil has been evenly distributed throughout the tool. The tool should be stored in a clean and dry environment.

Recommended lubricants: use air-tool oil or any other high-grade turbine oil containing moisture absorbent, rust inhibitors, metal wetting agents and an EP (extreme pressure) additive.

Clean the tool all over with a cotton rag after each use. Keep the tool in a dry and safe place out of reach of children.

PARTS LIST

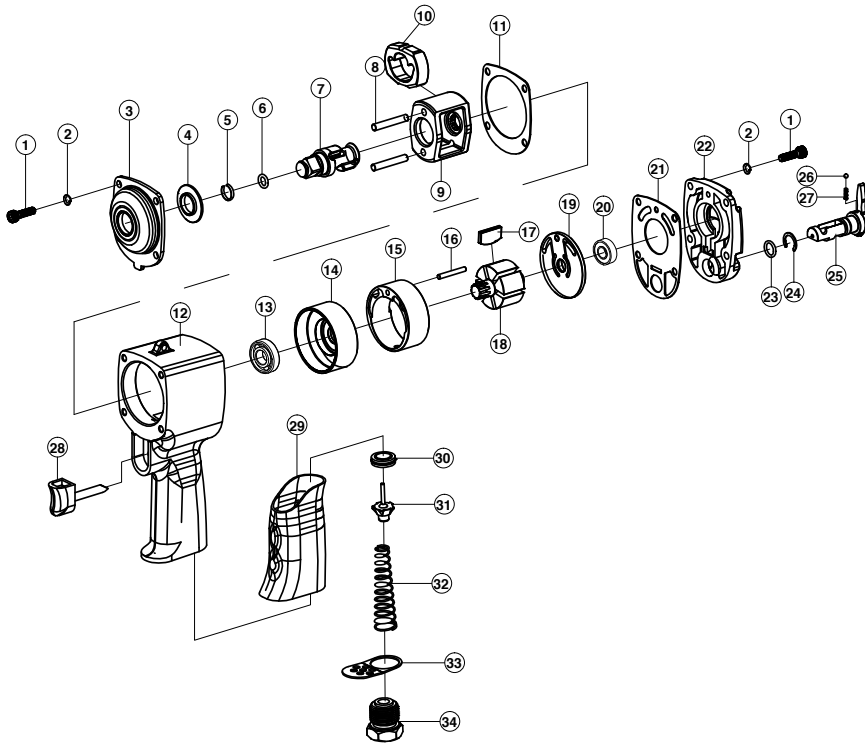

Item No	Description	Quantity	Item No	Description	Quantity
1	Inner Hexagon Screw	8	18	Rotor	1
2	Spring Washer	8	19	Rear Cylinder Cover	1
3	Front Cover	1	20	Bearing	1
4	Oil Sleeve	1	21	Gasket	1
5	Axis Protecting Ring	1	22	Seal Cover	1
6	O Ring	1	23	O Ring	1
7	Axis	1	24	E Ring	1
8	Impact Frame Fixed Pin	2	25	Speed Control Knob	1
9	Impact Frame	1	26	Steel ball	1
10	Hammer	1	27	Knob Spring	1
11	Front Cover Seal Ring	1	28	Trigger	1
12	Housing	1	29	Jacket	1
13	Bearing	1	30	Framework Oil Seal	1
14	Front Cylinder Cover	1	31	Inclined Valve	1
15	Cylinder	1	32	Air Inlet Spring	1
16	Cylinder Fixed Pin	1	33	Silencing Cover	1
17	Blade	1	34	Air Inlet	1

TROUBLESHOOTING

INSUFFICIENT POWER:

Probable Cause	Solution
Dirty or clogged air passages.....	Flush and lubricate tool, drain air tank and supply line
Insufficient air supply.....	Increase line pressure, Make sure compressor matches tool's air pressure and consumption needs
Air leakage.....	Use PTFE tape at all fittings and joints. Check tool for worn or damaged O-rings & seals.
Worn/damaged wear & tear parts ..	Replace as necessary.
Tool matching	Be sure you are using a tool suited for the torque requirements of the job at hand.