

IMPACT WRENCH

Butterfly

Stock Number M562DB

OWNER'S MANUAL



FOR YOUR SAFETY,
please read these instructions carefully and retain them for future use.

**Performance
Tool®**

SPECIFICATIONS

Square Drive (IN.)	3/8
Working Torque (FT. /LBS).....	20-75
Air Pressure (PSI).....	90
Average Air Consumption (CFM)	3
Free Speed (RPM).....	11000
Bolt Capacity (IN.).....	3/8
Air Inlet (NPT).....	1/4 in.
Hose Size (ID).....	3/8 in.
Weight (LBS)	2.0

Specifications are subject to change without notice

IMPORTANT SAFETY INFORMATION

WARNING!

READ, UNDERSTAND AND FOLLOW ALL INSTRUCTIONS AND WARNINGS BEFORE OPERATING THIS TOOL. FAILURE TO DO SO MAY RESULT IN PERSONAL INJURY AND/OR PROPERTY DAMAGE AND WILL VOID WARRANTY.

Warning!

Oil tool before each use. 4 to 5 drops of a good grade Air Tool Oil placed in the air inlet is sufficient. Use proper air pressure and CFM rating listed for this tool.

1. Keep work area clean. Cluttered areas invite injuries.
2. Observe work area conditions. Do not use machines or power tools in damp or wet locations. Don't expose to rain. Keep work area well lighted. Do not use electrically powered tools in the presence of flammable gases or liquids. Do not bring combustible materials near the tools.
3. Keep children away. Children must never be allowed in the work area. Do not let them handle machines, tools, hoses or extension cords.
4. Store idle equipment. When not in use, tools must be stored in a dry location to inhibit rust. Always lock up tools and keep out of reach of children and other untrained persons. Switch off all unused electrical tools when stored. Tools are dangerous in the hands of untrained users.
5. Always wear approved eye protection when using tools. If raising dust, wear a suitable mask.
6. Work Safe. Do not wear loose clothing or jewelry that could become caught by moving parts, causing injury. Operate tool a safe distance from yourself and others in the work area. Keep proper footing and balance at all times. Do not reach over or across running machines, hoses, etc.
7. Do not operate any tool if under the influence of alcohol or drugs. Read

IMPORTANT SAFETY INFORMATION

warning labels on prescriptions to determine if your judgment or reflexes are impaired while taking drugs. If there is any doubt, do not operate any tool.

8. Be sure air is in OFF position when connecting tool to air supply.
9. Use only those accessories that are designed for use with tools. For example, with impact wrenches do not use ordinary sockets. Use impact sockets for all air tools.
10. Be sure to disconnect tool from air supply before changing accessories, performing service on tool and when not in use.
11. Follow air source manufacturers' directions for connection of regulators, filters, and other accessories to air source. Do not install quick couplers directly on tool as they put unnecessary strain on the air inlet threads possibly causing them to wear out prematurely. Instead, install them on a short length of air hose attached to the tool.
12. Check for damaged parts. Before using any tool, any part that appears damaged should be carefully checked to determine that it will operate properly and perform its intended function. Check for alignment and binding of moving parts; any broken parts or mounting fixtures; and any other condition that may affect proper operation. Any part that is damaged should be properly repaired or replaced by a qualified technician.
13. Maintenance. For your safety, maintenance should be performed regularly by a qualified technician using original PERFORMANCE TOOLS® replacement parts. Failure to do so can lead to accidents for the operator. Use of any other parts will void the warranty. Only use accessories intended for use with this tool. Approved accessories are available from Performance Tool®. Use only accessories that are recommended by the manufacturer for your model. Accessories that may be suitable for one tool may become hazardous when used on another tool.

WARNING: This product and its packaging contain a chemical known to the State of California to cause cancer, birth defects, or other reproductive harm.

WARNING: The warnings, cautions, and instructions discussed in this instruction manual cannot cover all possible conditions and situations that may occur. It must be understood by the operator that common sense and caution are factors which cannot be built into this product, but must be supplied by the operator. Read and understand all of the instructions provided in the instruction manual of this product, as well as, any other tool (s) used with this product.

OPERATION

1. To set the tool to desired torque, select a nut or screw of known tightness of the same size, thread pitch and thread condition as those on the job.
2. Turn air regulator to low position, apply wrench to nut and gradually increase power (turn regulator to admit more air) until nut moves slightly in the direction it was originally set. The tool is now set to duplicate that tightness, note regulator setting for future use.
3. When tightening nuts not requiring critical torque values, run nut up flush and then tighten an additional one quarter to one-half turn (slight additional turning is necessary if gaskets are being clamped).
4. For additional power needed on disassembly work, turn regulator to its fully open position. This impact wrench is rated at 1 1/2 USS bolt size. Rating must be down graded for spring U bolts, tie bolts, long cap screws, double depth nuts, badly rusted conditions and spring fasteners as they absorb much of the impact power. When possible, clamp or wedge the bolt to prevent spring back.
5. Soak rusted nuts in penetrating oil and break rust seal before removing with impact wrench. If nut does not start to move in three to five seconds use a larger size impact wrench. Do not use impact wrench beyond rated capacity as this will drastically reduce tool life.

AIR SOURCE

Clean air of correct air pressure is recommended for the power supply for this tool. A maximum of 90 PSI at the tool is recommended for most air tools of this class. Check specifications section for recommended pressure. (Depending on length of air hose and other circumstances, air pressure at compressor may need to be increased to 100 PSI to ensure 90 PSI at the tool.)

Water in the air hose and compressor tank contributes to reduced performance and damage of the air tool. Drain the air tank and filters before each use and as necessary to keep the air supply dry.

Hose length over 25' causes loss in line pressure. Increase hose I.D. or increase compressor pressure to compensate for the pressure loss. Use an in-line pressure regulator with gauge if air inlet pressure is critical.

LUBRICATION & MAINTENANCE

Warning!

Oil tool before each use. 4 to 5 drops of a good grade Air Tool Oil placed in the air inlet is sufficient. Use proper air pressure and CFM rating listed for this tool.

Drain water from hoses and compressor tank. Water in the air supply line will cause gumming and loss of power. Clean the air filter on the supply line and flush the tool with gum solvent or a 50/50 mix of air tool oil and kerosene. It may be necessary to disassemble the tool to properly clean and re-lubricate.



Yes

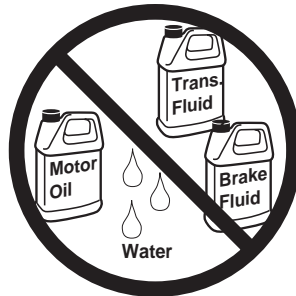

No

TROUBLESHOOTING

INSUFFICIENT POWER:

Probable Cause

Solution

Dirty or clogged air passages

Flush and lubricate tool, drain air tank and supply line

Insufficient air supply

Increase line pressure, make sure compressor matches tool's air pressure and consumption needs

Air leakage

Use PTFE tape at all fittings and joints. Check tool for worn or damaged O-rings & seals.

Worn/damaged wear & tear parts

Replace as necessary.

Tool matching

Be sure you are using a tool suited for the requirements of the job at hand.

REPLACEMENT PARTS LIST

#	Part #	Description	Quantity
1	–	Housing	1
2	–	Anvil Bushing	1
3	M562K-01	Anvil Collet	1
4	M562K-01	O-Ring	1
5	M562K-01	Anvil	1
6	–	Hammer Pin	1
7	M562K-01	Hammer Dog	1
8	M562K-01	Drive Cam	1
9	–	Hammer Cage	1
10	–	Screw	1
11	–	Trigger Pin	2
12	–	Trigger Pin	1
13	M562K-01	Front Bearing	1
14	–	Protective Rubber	1
15	M562K-01	Front Plate	1
16	–	Rotor	1
17	M562K-01	Rotor Blade	6
18	–	Cylinder	1
19	–	Cylinder pin	1
20	M562K-01	Rear Cover	1
21	M562K-01	Rear Bearing	1
22	–	Seal Gasket	1
23	–	Seal Cover	2
24	–	Inlet Seat	1
25	–	Air Regulator	1
26	M562K-01	O-Ring	6
27	M562K-01	O-Ring	2
28	–	Spring	2
29	–	Switch Pin	2
30	–	Switch Spring	2
31	–	Valve Seat	2
32	M562K-01	O-Ring	1
33	M562-01	O-Ring	1
34	–	Screw	4
35	–	Gasket	1
36	–	Anvil Collet	1
37	–	Spring	1
38	–	Steel Ball	1
39	–	Retainer Plate	1
40	–	Screw	2
41	–	Oil seal	1

REPLACEMENT PARTS LIST

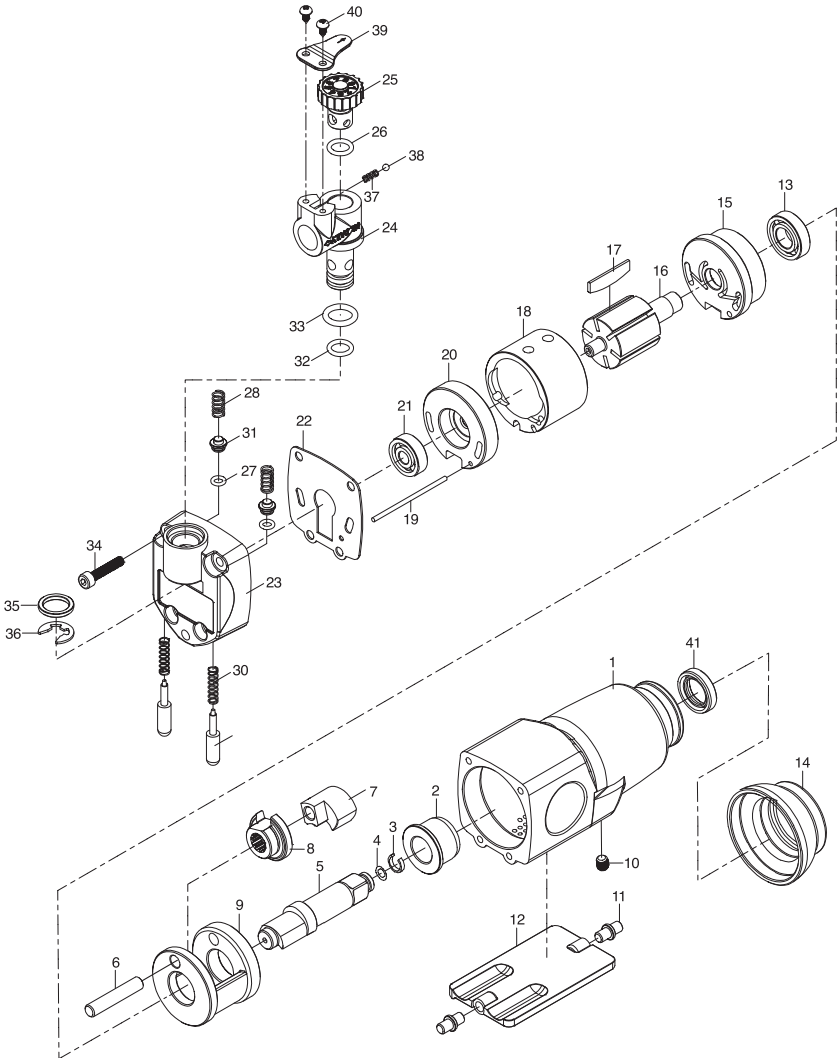

LIMITED WARRANTY

PERFORMANCE TOOL® extends only the following warranties, and only to original retail purchasers. These warranties give specific legal rights. Except where prohibited by local law, the law of the State of Washington governs all warranties and all exclusions and limitations of warranties and remedies. There may be other rights which vary from state to state.

PERFORMANCE TOOL® warrants the product to be free from defects in materials and workmanship under normal use and service. A defective product may be returned for a free replacement within 90 days from the date of purchase, provided that product is returned to place of purchase immediately after discovery of defect. After 90 days and up to one year from date of purchase, PERFORMANCE TOOL® will replace at no charge any parts which our examination shall disclose to be defective and under warranty.

These warranties exclude blades, bits, punches, dies, bulbs, fuses, hoses, and other consumables which must be replaced under normal use and service. These warranties shall not apply to any product or part which is used for a purpose for which it is not designed, or which has been repaired or altered in any way so as to affect adversely its performance or reliability, nor shall these warranties apply to any product or part which has been subject to misuse, neglect, accident or wear and tear incident to normal use and service.

PERFORMANCE TOOL® does not authorize any other person to make any warranty or to assume any liability in connection with its products.

Except for warranties of title and the limited express warranties set forth above, PERFORMANCE TOOL® makes no express or implied warranties of any kind with respect to its products. In particular, PERFORMANCE TOOL® makes no implied warranty of merchantability and no implied warranty of fitness for any particular purpose, except that for goods purchased primarily for personal, family or household use and not for commercial or business use, PERFORMANCE TOOL® makes an implied warranty of merchantability (and, if otherwise applicable, an implied warranty of fitness for a particular purpose), but only for the particular qualities or characteristics, and for the duration, expressly warranted above.

The laws on limitation of implied warranties may differ from state to state, so the above limitations may not apply in all cases.

PERFORMANCE TOOL® shall not be liable for consequential, incidental or special damages resulting from or in any manner related to any product, or to the design, use, or any inability to use the product. The sole and exclusive remedy for a defective product or part shall be the repair, or replacement thereof as provided above. The laws on limitation of remedies or on consequential, incidental or special damages may vary from state to state, so the above limitations may not apply in all cases.