

**Parts List &  
Operating Instructions**

for:

**9104B  
9110B**

**Hydraulic Cylinders**

9104B Max. Capacity: 4 Tons

9110B Max. Capacity: 10 Tons

**9104B**

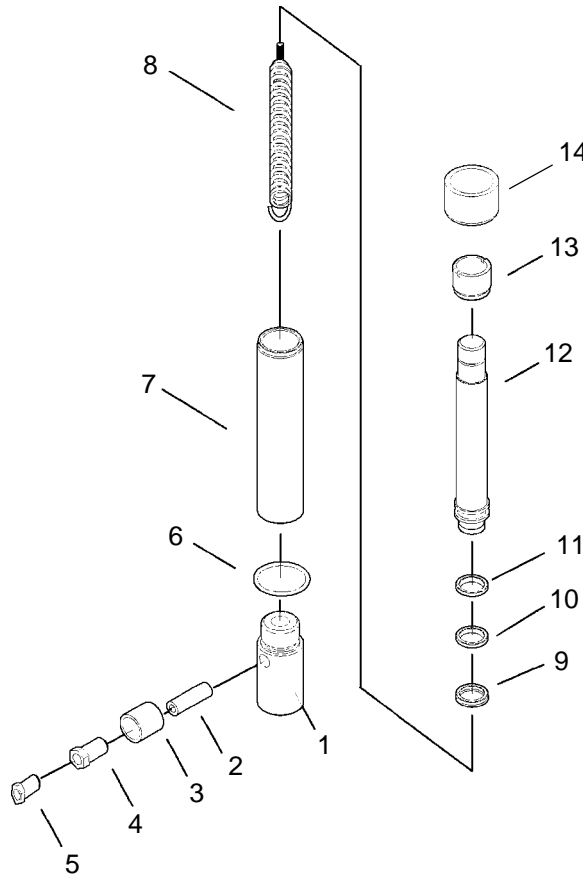

**Parts List and Replacement Kits for 9104B**

**Parts List**

Item No.	Qty.	Description
1	1	Cylinder Base
2	1	Pin
3	1	Coupling Ring
4	1	Coupler
5	1	Plug
6	1	O-ring
7	1	Cylinder
8	1	Spring
9	1	Seal
10	1	Nylon Gasket
11	1	Piston Ring
12	1	Piston Rod
13	1	Bushing
14	1	Ram Sleeve

**Replacement Kits**

Item No.	Qty.	Description
<b>No. 544763 Seal Kit</b>		
6	1	O-ring
9	1	Seal
10	1	Nylon Gasket
11	1	Piston Ring
<b>No. 544790 Spring Kit</b>		
2	1	Pin
6	1	O-ring
8	1	Spring
<b>No. 544791 Ram Kit</b>		
6	1	O-ring
9	1	Seal
10	1	Nylon Gasket
11	1	Piston Ring
12	1	Piston Rod
<b>No. 544793 Ram Sleeve Kit</b>		
14	1	Ram Sleeve
<b>No. 544794 Cylinder Kit</b>		
6	1	O-ring
7	1	Cylinder
13	1	Bushing
<b>No. 544795 Base Kit</b>		
1	1	Cylinder Base
6	1	O-ring
<b>No. 544788 Ram Half Coupler Kit</b>		
3	1	Coupling Ring
4	1	Coupler
5	1	Plug

# Parts List & Operating Instructions

## Parts List and Replacement Kits for 9110B

**9110B**

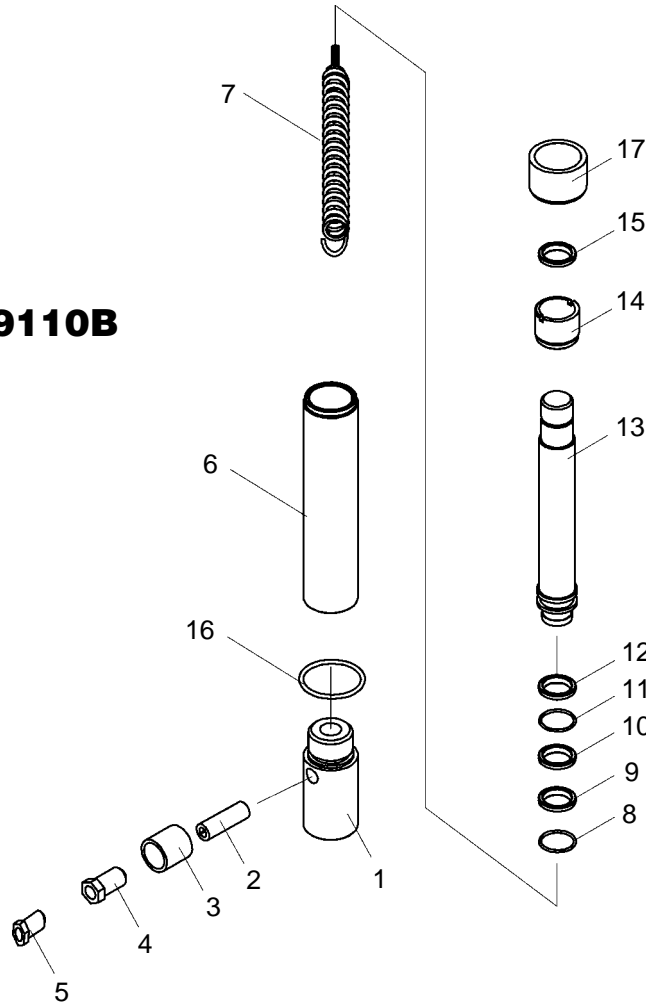

### Parts List

Item No.	Qty.	Description
1	1	Cylinder Base
2	1	Pin
3	1	Coupling Ring
4	1	Coupler
5	1	Plug
6	1	Cylinder
7	1	Spring
8	1	Retaining Ring
9	1	Retainer
10	1	Piston Ring
11	1	O-ring
12	1	Seal
13	1	Piston Rod
14	1	Fasten Nut
15	1	Reinforced Ring
16	1	O-ring
17	1	Ram Sleeve

### Replacement Kits

Item No.	Qty.	Description
<b>No. 544766 Seal Kit</b>		
9	1	Retainer
10	1	Piston Ring
11	1	O-ring
12	1	Seal
16	1	O-ring
<b>No. 544796 Spring Kit</b>		
2	1	Pin
7	1	Spring
16	1	O-ring
<b>No. 544797 Ram Kit</b>		
8	1	Retaining Ring
9	1	Retainer
10	1	Piston Ring
11	1	O-ring
12	1	Seal
13	1	Piston Rod
16	1	O-ring

Item No.	Qty.	Description
<b>No. 544799 Ram Sleeve</b>		
17	1	Ram Sleeve
<b>No. 544801 Cylinder Kit</b>		
6	1	Cylinder
14	1	Fasten Nut
15	1	Reinforced Ring
16	1	O-ring
<b>No. 544802 Base Kit</b>		
1	1	Cylinder Base
16	1	O-ring
<b>No. 544788 Ram Half Coupler Kit</b>		
3	1	Coupling Ring
4	1	Coupler
5	1	Plug

## Single-Acting Hydraulic System

A basic single-acting hydraulic system consists of a manual or power pump that moves the hydraulic fluid, a hydraulic hose that carries the fluid, and a cylinder or ram that the fluid moves to do a job.

The cylinder, hose(s), couplings, and pump all must be rated for the same maximum operating pressure, correctly connected, and compatible with the hydraulic fluid used. An incorrectly matched system can cause the system to fail and possibly cause serious injury.

### INTRODUCTION

These instructions are written to help you, the user, more effectively use and maintain your hydraulic cylinders. If you have any questions, call your nearest OTC distributor.

Some of the information included in these instructions was selected from the ANSI B30.1 Standards and applies to the construction, installation, operation, inspection, and maintenance of the hydraulic cylinders. It is strongly recommended that you read ANSI B30.1 to answer any questions not covered in these instructions.

### TYPICAL INSTALLATION

Since the single-acting cylinders have only one hose going to the cylinder, the cylinder can only apply force to extend its rod. The return stroke is accomplished by spring force.

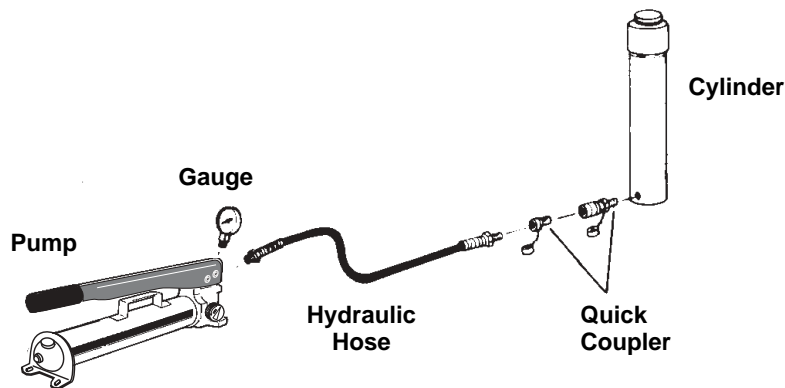

## Parts List & Operating Instructions

**⚠ WARNINGS:** To prevent personal injury,



- Read and understand all safety precautions and operating instructions before using this cylinder. If the operator cannot read English, operating instructions and safety precautions must be read and discussed in the operator's native language.

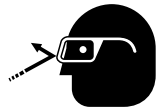

- Failure to follow these warnings could cause a loss of load, damage to equipment, and / or failure of equipment, which may result in personal injury or property damage.

- Wear eye protection that meets ANSI Z87.1 and OSHA standards.

- When extending a cylinder or ram under load, ensure the couplers or port threads have not been damaged, and they will not come in contact with any rigid obstruction. If this condition occurs, the coupler's attaching threads may become stripped or pulled from the cylinder or ram, resulting in the release of high pressure hydraulic fluid, flying objects, and loss of load.

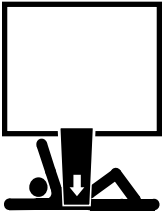

- Avoid off-center loads that could damage the cylinder or ram and/or cause loss of load. Control the load at all times to prevent thread shearing and loss of load. Ensure everyone is clear of the load.

- Before operating the pump, all hose connections must be tightened securely and leak-free—do not overtighten. Overtightening can cause premature thread failure or high pressure fittings to split at pressures lower than their rated capacities.

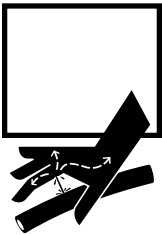

- Should a hydraulic hose rupture, burst, or become disconnected, immediately shut off the pump and release all pressure. Never grasp a leaking pressurized hose with your hands. The force of escaping fluid could cause serious injury.

- Periodically inspect the hose for wear. Do not subject the hose to potential hazards such as fire, sharp surfaces, extreme heat or cold, or heavy impact. Do not allow the hose to kink, twist, curl, crush, cut, or bend so tightly that fluid flow within the hose is blocked or reduced. These conditions could damage the hose, which could result in personal injury.

- To prevent deterioration, hoses must not come in contact with corrosive materials, such as creosote-impregnated objects and some paints. Hose deterioration can result in personal injury. Consult the manufacturer before painting a hose. Never paint a coupler.

- Do not use the hose to move attached equipment. Stress can damage the hose and possibly cause personal injury.

- Hose material and coupler seals must be compatible with the hydraulic fluid used. Use only approved hydraulic fluid.

- Appropriately rated adapters must be installed and used correctly for each application.

- To prevent expelling high pressure oil into the atmosphere, do not extend the cylinder beyond the suggested maximum stroke. If this does occur, seals must be replaced.

- Do not exceed the rated capacity of the cylinder. Excess pressure can result in personal injury.
- Inspect each cylinder and coupler before each use to prevent unsafe conditions from developing. Do not use cylinders if they are damaged, altered, or in poor condition. Do not use cylinders with bent or damaged couplers or damaged port threads.
- Under certain conditions, the use of an extension with a hydraulic cylinder may not be advisable and could present a dangerous condition.
- Avoid pinch points or crush points that can be created by the load or parts of the cylinder.
- Never use extreme heat to disassemble a hydraulic cylinder or ram. Metal fatigue and/or seal damage will result and can lead to unsafe operating conditions.

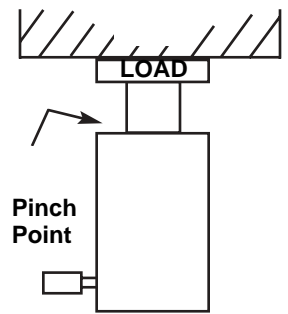

This guide cannot cover every hazard or situation—use the cylinder with **SAFETY FIRST**.

#### IMPORTANT:

- Keep the cylinder clean at all times.
- When the cylinder is not in use, keep the piston rod fully retracted and upside down.
- Use an approved, high-grade pipe thread sealant to seal all hydraulic connections. Teflon tape can be used if only one layer of tape is used, and it is applied carefully (two threads back) to prevent the tape from being pinched by the coupler and broken off inside the pipe end. Any loose pieces of tape could travel through the system and obstruct the flow of fluid or cause jamming of precision-fit parts.
- Use protective covers on disconnected quick couplers.
- Limit the stroke on spring return cylinders to prolong spring life.

## Set-Up

### Hydraulic Connections

Remove thread protectors or dust covers from the hydraulic ports, if applicable. Clean the areas around the fluid ports of the pump and cylinder. Inspect all threads and fittings for signs of wear or damage, and replace as needed. Clean all hose ends, couplers, and union ends. Connect all hose assemblies to the pump and cylinder. Use an approved, high-grade pipe sealant to seal all hydraulic connections. Tighten securely and leak-free, but do not over tighten.

Hydraulic lines and fittings can act as restrictors as the cylinder or ram retracts. The restricting or slowing of the fluid flow causes back pressure that slows the cylinder's or ram's return. Return speed also varies because of the application, condition of the cylinder or ram, inside diameter of hose or fitting, length of the hose, and the temperature and viscosity of the hydraulic fluid.

**CAUTION:** Do not allow the hose to kink, twist, curl, crush, cut, or bend so tightly that the fluid flow within the hose is blocked or reduced.

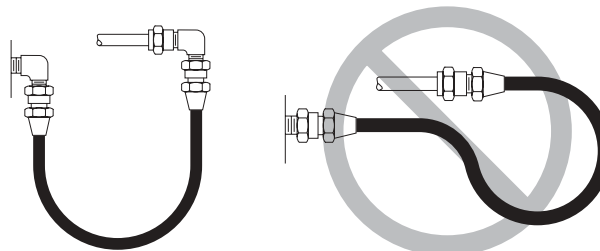

# Parts List & Operating Instructions

---

## Bleeding the System

After all connections are made, the hydraulic system must be bled of any trapped air. Refer to the diagram below.

With no load on the system, and the pump vented and positioned higher than the cylinder or ram, cycle the system several times. If you are in doubt about venting the pump, read the operating instructions for your pump. Check the reservoir for possible low fluid level and fill to correct level with approved, compatible, hydraulic fluid as necessary.

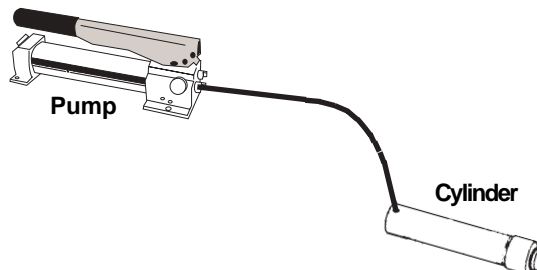

**IMPORTANT: Some spring return cylinders, or rams, have a cavity in the rod which forms an air pocket. This type of cylinder or ram should be bled when positioned upside down or lying on its side with the port facing upward.**

## Inspection

Before each use, visually inspect for the following items:

1. Cracked or damaged cylinder
2. Excessive wear, bending, damage, or insufficient part engagement
3. Leaking hydraulic fluid
4. Scored or damaged piston rod
5. Swivel heads and caps not functioning correctly
6. Loose bolts
7. Damaged or incorrectly assembled accessory equipment
8. Modified, welded, or altered equipment
9. Bent or damaged couplers or port threads

Preventive Maintenance (yearly, or sooner if the cylinder or ram condition suggests damage)—Visual examination by the operator or other designated personnel with a dated and signed equipment record.

## Maintenance

### Periodic Cleaning

Follow these maintenance tips to keep your equipment in its best working condition:

- Keep the hydraulic system, including hose connections and equipment attached to the cylinder, as free from dirt and grime as possible. Seal all unused couplers with dust covers.
- Use only OTC hydraulic fluid and change as recommended, or sooner, if the fluid becomes contaminated (never exceed 300 hours).
- Exposed threads (external or internal) must be cleaned and lubricated regularly, and protected from damage.
- If a cylinder or ram has been exposed to rain, snow, sand, grit-laden air, or any corrosive environment, it must be cleaned, lubricated, and protected immediately after exposure.

**Storage**

Cylinders and rams should be stored in a vertical position with the rod end down in a dry, well-protected area, where they will not be exposed to corrosive vapors, dust, or other harmful elements. When a cylinder or ram has not been used for three (3) months, it should be connected to a pump, be fully extended and then retracted to lubricate the cylinder walls, thereby reducing the potential for rust formation.

**Troubleshooting Guide**

**IMPORTANT:** The following troubleshooting and repair procedures should be performed by qualified personnel familiar with this equipment and using the proper equipment.

**NOTE:** All the following statements may not apply to your particular model of cylinder or ram. Use the guide as a general reference for troubleshooting.

Trouble	Cause	Solution
<b>Erratic action</b>	<ol style="list-style-type: none"> <li>1. Air in system or pump cavitation.</li> <li>2. Internal leakage in double-acting cylinders or external leakage in single-acting cylinders.</li> <li>3. Cylinder sticking or binding.</li> </ol>	<ol style="list-style-type: none"> <li>1. Add fluid, bleed air, and check for leaks.</li> <li>2. Replace worn packings. Check for excessive contamination or wear. Replace contaminated fluid as necessary.</li> <li>3. Check for dirt or leaks. Check for bent, misaligned, worn parts or defective packings.</li> </ol>
<b>Cylinder/Ram does not move</b>	<ol style="list-style-type: none"> <li>1. Loose couplers.</li> <li>2. Faulty coupler.</li> <li>3. Incorrect pump valve position.</li> <li>4. Low or no hydraulic fluid in pump reservoir.</li> <li>5. Air-locked pump.</li> <li>6. Pump not operating.</li> <li>7. Load is above the capacity of the system.</li> <li>8. Fluid leaks out of rod end relief valve (double-acting cylinders only).</li> </ol>	<ol style="list-style-type: none"> <li>1. Tighten couplers.</li> <li>2. Verify the internal coupler is not locked up (ball wedged into seat). Replace both internal and external couplers.</li> <li>3. Close release valve or shift to new position.</li> <li>4. Fill and bleed the system.</li> <li>5. Prime pump per pump operating instructions.</li> <li>6. Check pump's operating instructions.</li> <li>7. Use the correct equipment.</li> <li>8. Verify all couplers are fully coupled. Contact your nearest Authorized Hydraulic Service Center.</li> </ol>
<b>Cylinder/Ram extends only partially</b>	<ol style="list-style-type: none"> <li>1. Pump reservoir is low on hydraulic fluid.</li> <li>2. Load is above the capacity of the system.</li> <li>3. Cylinder piston rod binding.</li> </ol>	<ol style="list-style-type: none"> <li>1. Fill and bleed the system.</li> <li>2. Use the correct equipment.</li> <li>3. Check for dirt or leaks. Check for bent, misaligned, worn parts or defective packings.</li> </ol>
<b>Cylinder/Ram moves slower than normal</b>	<ol style="list-style-type: none"> <li>1. Loose connection or coupler.</li> <li>2. Restricted hydraulic line or fitting.</li> <li>3. Pump not working correctly.</li> <li>4. Cylinder seals leaking.</li> </ol>	<ol style="list-style-type: none"> <li>1. Tighten.</li> <li>2. Clean and replace if damaged.</li> <li>3. Check pump operating instructions.</li> <li>4. Replace worn seals. Check for excessive contamination or wear.</li> </ol>
<b>Cylinder/Ram moves but does not maintain pressure</b>	<ol style="list-style-type: none"> <li>1. Leaky connection.</li> <li>2. Cylinder seals leaking.</li> <li>3. Pump or valve malfunctioning.</li> </ol>	<ol style="list-style-type: none"> <li>1. Clean, reseal with thread sealant and tighten connection.</li> <li>2. Replace worn seals. Check for excessive contamination or wear. Replace contaminated fluid as necessary.</li> <li>3. Check pump or valve operating instructions.</li> </ol>

## Parts List & Operating Instructions

---

### Troubleshooting Guide Contd.

---

<b>Trouble</b>	<b>Cause</b>	<b>Solution</b>
<b>Cylinder/Ram leaks hydraulic fluid</b>	<ol style="list-style-type: none"><li>1. Worn or damaged seals.</li><li>2. Loose connections.</li></ol>	<ol style="list-style-type: none"><li>1. <i>Replace worn seals. Check for excessive contamination or wear. Replace contaminated fluid as necessary.</i></li><li>2. <i>Clean, reseal with thread sealant and tighten connection.</i></li></ol>
<b>Cylinder/Ram will not retract or retracts slower than normal</b>	<ol style="list-style-type: none"><li>1. Pump release valve closed.</li><li>2. Loose couplers</li><li>3. Blocked hydraulic lines.</li><li>4. Weak or broken retraction springs.</li><li>5. Cylinder damaged internally.</li><li>6. Pump reservoir too full.</li></ol>	<ol style="list-style-type: none"><li>1. <i>Open pump release valve.</i></li><li>2. <i>Tighten couplers</i></li><li>3. <i>Clean and flush.</i></li><li>4. <i>Send to service center for repair.</i></li><li>5. <i>Send to service center for repair.</i></li><li>6. <i>Drain hydraulic fluid to correct level.</i></li></ol>