Hydraulic Hub Grapppler™ Kit



Explanation of Safety Signal Words

The safety signal word designates the degree or level of hazard seriousness.

DANGER: Indicates an imminently hazardous situation which, if not avoided, will result in death or serious injury.

WARNING: Indicates a potentially hazardous situation which, if not avoided, could result in death or serious injury.

CAUTION: Indicates a potentially hazardous situation which, if not avoided, may result in minor or moderate injury.

CAUTION: Used without the safety alert symbol indicates a potentially hazardous situation which, if not avoided, may result in property damage.

Safety Precautions



WARNING: To prevent personal injury and/ or equipment damage,



- Study, understand, and follow all safety precautions and operating instructions before using this hydraulic Hub Grappler™ kit. If the operator cannot read instructions, operating instructions and safety precautions must be read and discussed in the operator's native language.



- Only qualified operators may install, operate, adjust, maintain, clean, repair, inspect, or transport this hydraulic Hub Grappler™ kit.
- Wear eye protection that meets ANSI Z87.1, CE EN166, AS/NZS 1337, and OSHA standards.
- Cover the work with a protective blanket or canvas because applying force can cause breakage.
- Do not use this hydraulic Hub Grappler™ kit for anything other than its intended purpose.
- No alteration shall be made to this product.
- Inspect the condition of the hydraulic Hub Grappler™ kit before each use; do not use if damaged, altered, or in poor condition.
- Use only those repair parts called out in the parts list in this document. Items found in the parts list have been carefully tested and selected by OTC.

Hose



- Before operating the pump, tighten all hose connections using the correct tools. Do not overtighten; connections need only be secure and leak-free. Overtightening can cause premature thread failure or high pressure fittings to split at pressures lower than their rated capacities.
- Should a hydraulic hose ever rupture, burst, or need to be disconnected, immediately shut the pump OFF, and open the control valve to release all pressure. NEVER grasp a leaking, pressurized hose with your hands; the force of escaping hydraulic fluid could cause serious injury.
- Do not subject the hose to any potential hazard such as fire, extreme cold or heat, sharp surfaces, or heavy impact. Do not allow the hose to kink, twist, curl, or bend so tightly that the fluid flow within the hose is blocked or reduced. Do not use the hose to move attached equipment. Periodically inspect the hose for wear, because any of these conditions can damage the hose and result in personal injury.
- Hose material and coupler seals must be compatible with the hydraulic fluid used. Hoses also must not come in contact with corrosive materials, such as creosote-impregnated objects and some paints. Consult the manufacturer before painting a hose. Never paint couplers. Hose deterioration due to corrosive material can result in personal injury.

Pump

- Do not exceed the maximum capacity of the pump or tamper with the internal high pressure relief valve. Creating pressure beyond the rated capacity can result in personal injury.
- Completely retract the ram before opening the filler screw on the pump to add hydraulic fluid. An overfill can cause personal injury due to excess reservoir pressure created when rams are retracted.

Cylinder

- Do not exceed the maximum capacity of the cylinder. Creating pressure beyond the rated capacity can result in personal injury.
- Adapters must be aligned and fully engaged so ram force is straight, avoiding an off-center load condition.

Parts List

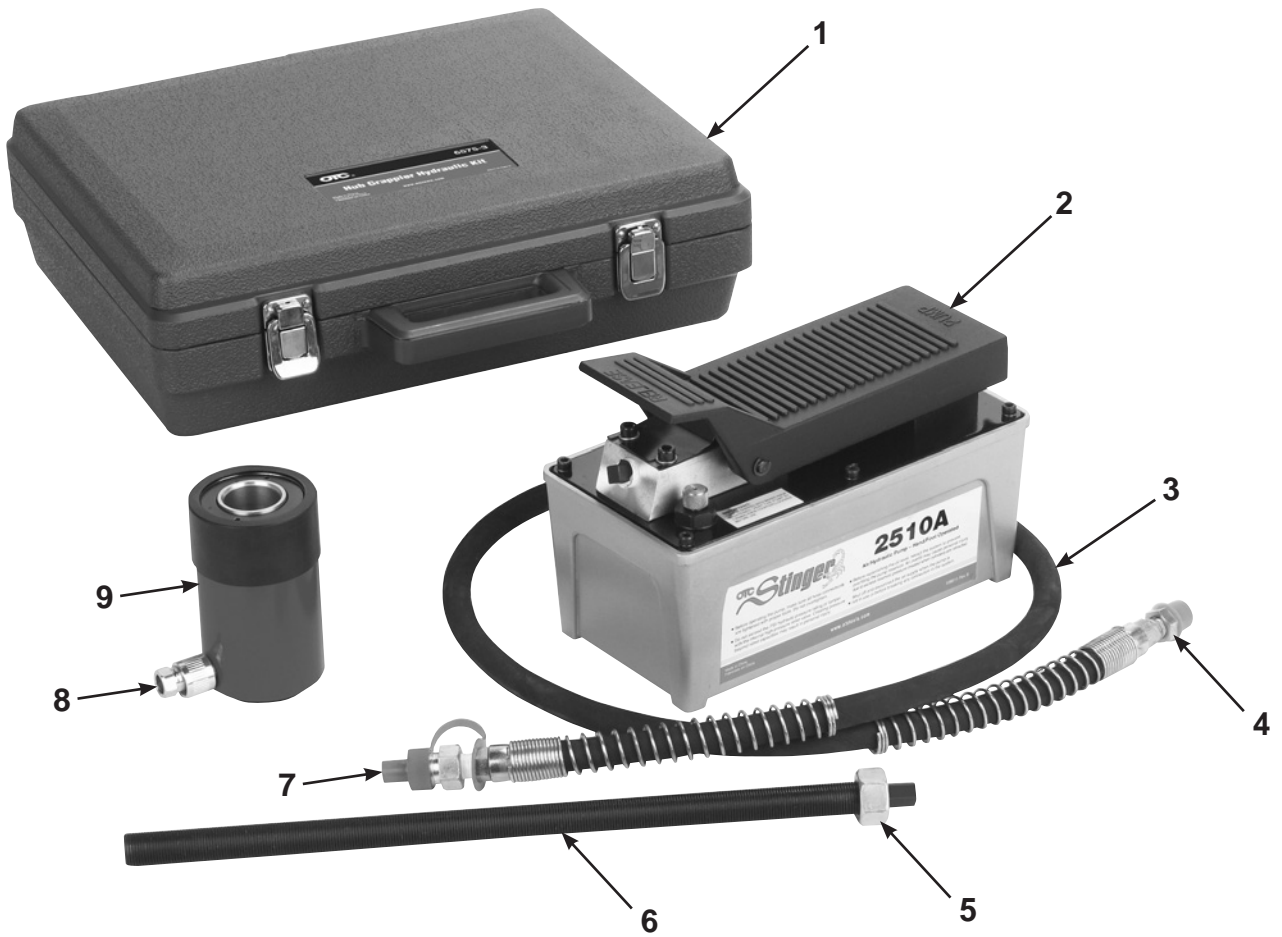

Item No.	Part No.	No. Req'd	Description
1	308343	1	Carrying Case
2	2510A	1	Air/Hydraulic Pump
3	544744	1	Hose – 1.83 M (6 foot) - 6.35 mm (.25 in.) NPT
4	10676	1	Straight Fitting
5	22301	1	Hex Nut – .75-16 UNF (Grade 8)
6	314194	1	Forcing Screw
7	544745	1	6.35 mm (.25 in.) Hose Half Coupler (Male)
8	544788	1	6.35 mm (.25 in.) Hose Half Coupler (Female)
9	562718	1	9-Ton Hollow Cylinder

Parts List and Operating Instructions

Instructions

This kit is to be used with the 6575 Hub Grappler™ Kit to add hydraulic function to removing and installing half shaft driven wheel bearings. It is not necessary to remove the knuckle assembly from the vehicle, and, as a result, wheel alignment is not altered.

Vehicle Setup

Raise the vehicle until all weight is off the wheels and they hang freely.

1. Remove the following components:

- tires
- axle nut
- outer tie rod nut and tie rod
- disc brake caliper - use a wire (or OTC No. 7661 caliper hanger set) to hold caliper out of the way and prevent damage to brake hose.
- brake rotor
- separate the lower ball joint from the knuckle assembly

2. Lubricate the forcing screw in the tool set.

3. Remove axle shaft from hub assembly. It may be necessary to push the axle shaft from hub assembly. Use a hub puller (OTC No. 7208A; not included) to push the axle shaft from the hub assembly. See Figure 1.

4. Use wire to tie the axle out of the way. Do not let it hang free. See Figure 2.

5. Refer to the Hub Grappler™ Application Guide (OTC No. 6575MAN-09) for information on which adapters to use with your specific vehicle model.

NOTE: If the race from the old bearing is still stuck in the hub, use puller assembly (OTC No. 7503) with race puller adapter (503896) to remove the race. See Figure 3.

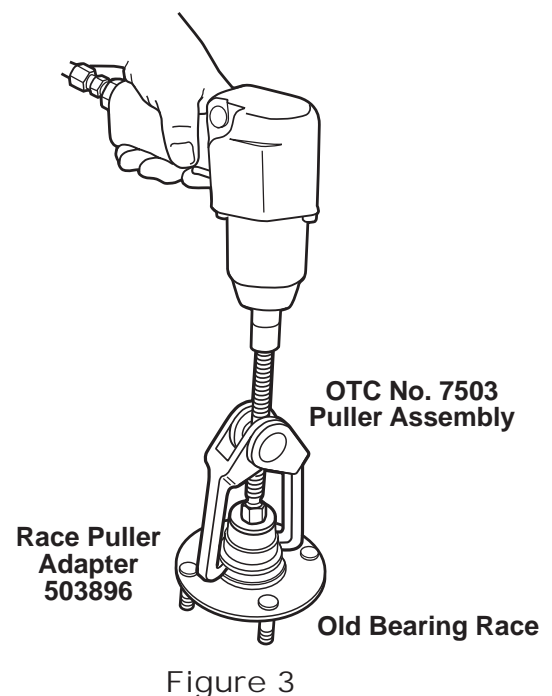
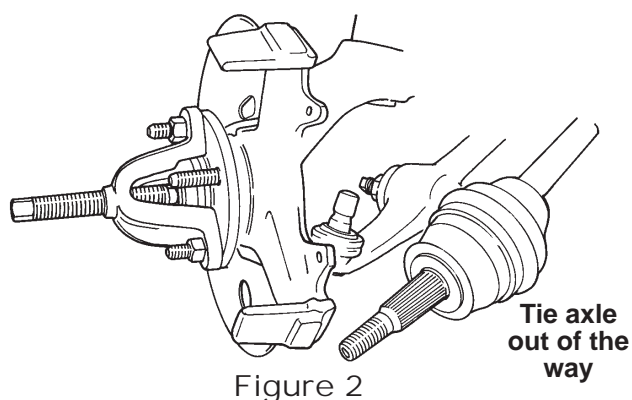
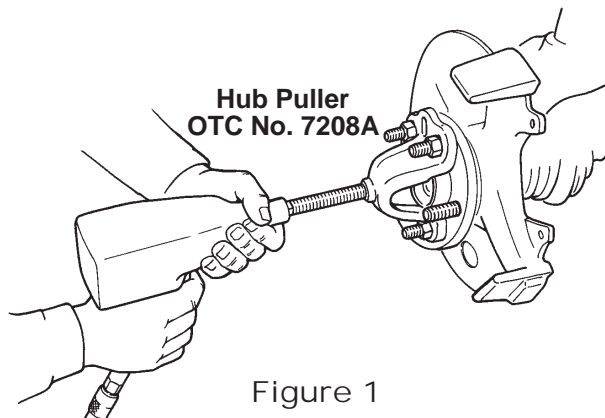

Front or Rear Hub Removal

1. Lubricate the forcing screw from this kit, assemble components, and attach Hub Grappler to hub as shown in Figure 4.
2. Align all components and tighten forcing screw nut to hold components for a straight pull.
3. Operate the pump to extend the cylinder piston just far enough to pull the the hub assembly.

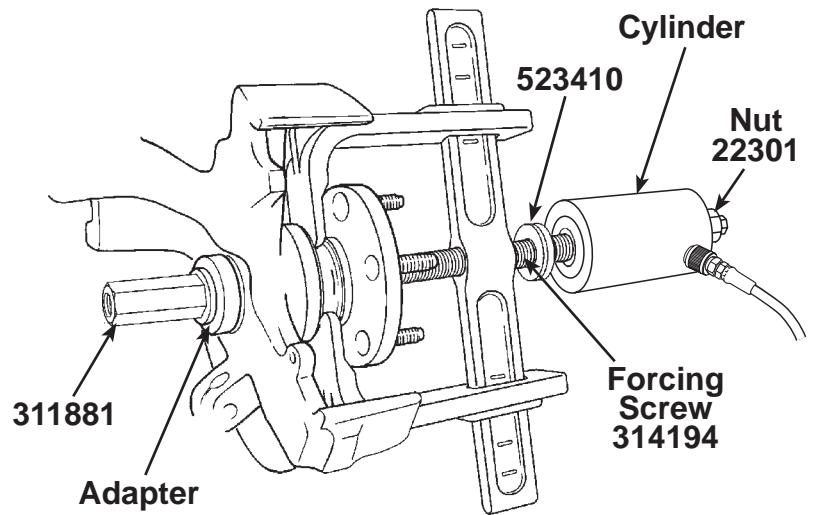

Figure 4

Bearing Removal

1. Remove the snap ring from the outboard (or inboard) side of the knuckle.
2. *For outboard side removal:*
Assemble the tool components as shown in Figure 5.
For inboard side removal:
Assemble the tool components as shown in Figure 6.
3. Align all components and tighten forcing screw nut to hold components for a straight push.
4. Operate the pump to extend the cylinder piston just far enough to press out the worn bearing.

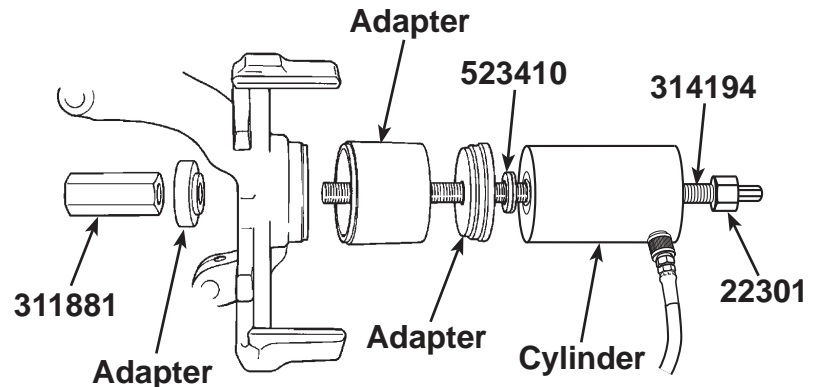

Figure 5

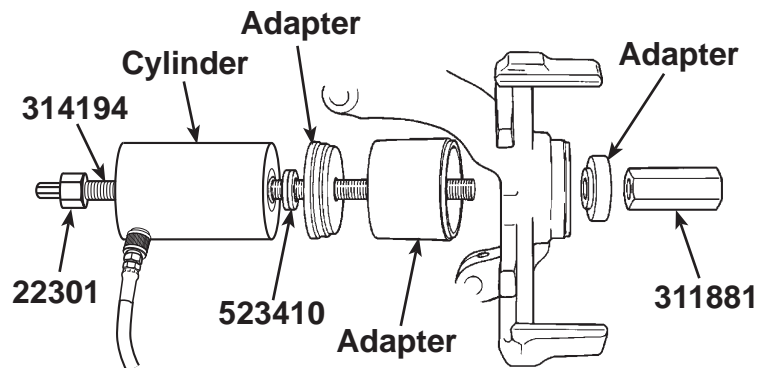

Figure 6

Bearing Installation

NOTE: The bearing installer must be assembled with the flat side toward the bearing and the small diameter pilot away from the bearing.

1. Lightly lubricate the new bearing, and position it for installation with the tool components assembled as shown in Figure 7 for outboard installation or Figure 8 for inboard installation.
2. Align all components and tighten forcing screw nut to hold components for a straight push.
3. Operate the pump to extend the cylinder piston to press the bearing into the spindle assembly until it bottoms.
4. Install the snap ring in the knuckle.

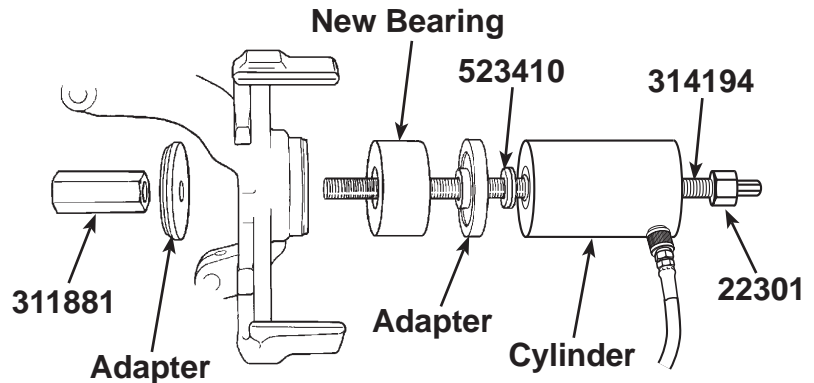

Figure 7

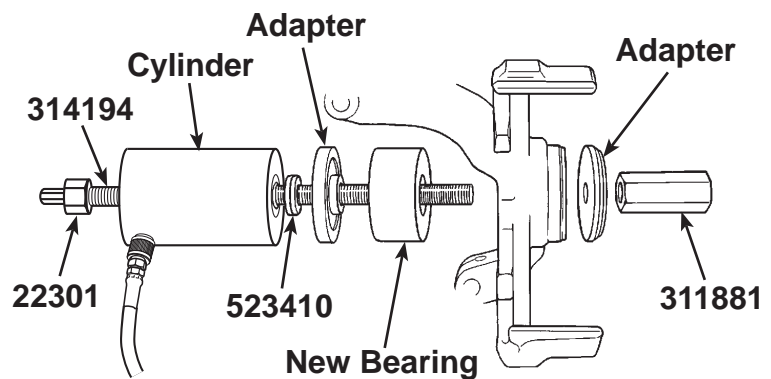

Figure 8

Front or Rear Hub Installation

NOTE: The bearing installer must be assembled with the flat side toward the bearing and the small diameter pilot away from the bearing.

1. Assemble the tool components as shown in Figure 9.
2. Align all components and tighten forcing screw nut to hold components for a straight push.
3. Operate the pump to extend the cylinder piston and install the hub.

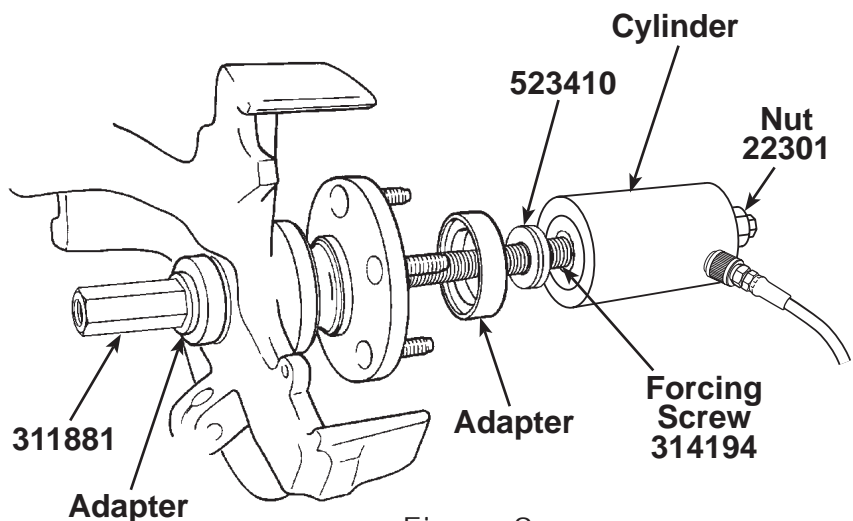

Figure 9