

Parts List &
Operating Instructions
for:

5180

Portable Multipurpose Press

Max. Capacity: 10 Tons

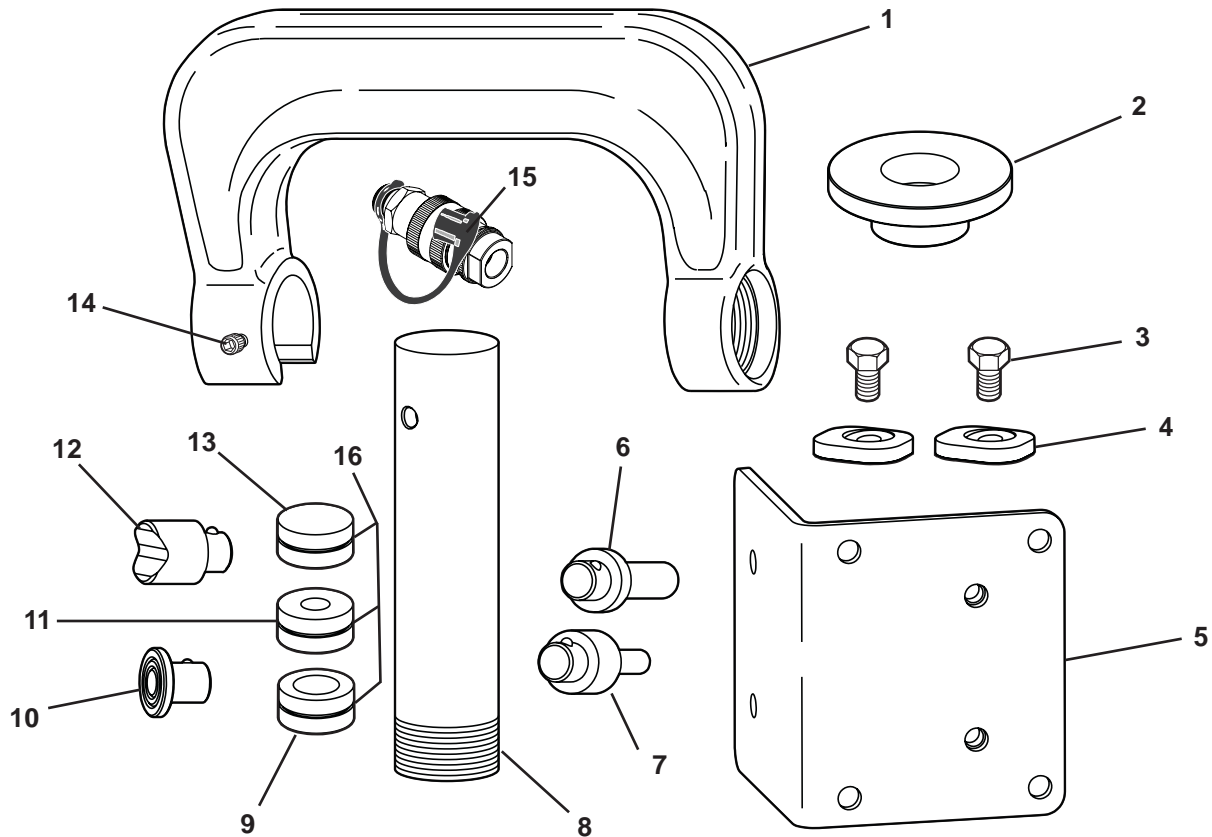

Item No.	Part No.	No. Req'd	Description	Item No.	Part No.	No. Req'd	Description
1	535350	1	C-Frame	9	549046	1	Pressing Adapter
2	536277	1	Adapter Base	10	548922	1	Flat Adapter
3	10075	2	Hex Hd. Cap Screw	11	549045	1	Pressing Adapter
4	536169	2	Clamp	12	536282	1	V-Pushing Adapter
5	536193	1	C-Frame Base	13	549044	1	Pressing Adapter
6	536281	1	Pushing Adapter	14	10006	1	Soc. Hd. Cap Screw
7	536280	1	Pushing Adapter	15	9195A	1	Coupler
8	548924	1	Cylinder Assembly (see Form No. 549377)	16	14875	3	O-ring

Parts List & Operating Instructions

Safety Precautions



CAUTION: To prevent personal injury:

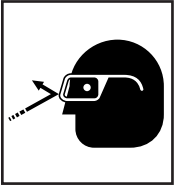

- The owner of the press is responsible for the press being installed and operated according to federal (OSHA), state, and local safety standards.
- The press operator, and anyone within sight of the press, must wear protective eyewear that meets the requirements of ANSI Z87.1 and OSHA.

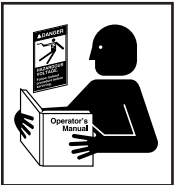

- Read, understand, and follow all safety precautions and operating instructions included with the press.
 - If the operator cannot read English, operating instructions and safety precautions must be read and discussed in the operator's native language.



- If using this press to repair a vehicle, block all wheels to prevent movement.
- Work pieces must be well supported and aligned so that ram force is straight, and parts being pressed cannot slip out or break.

- Keep hands out of the work area during a pressing operation.
- Locate the press in an isolated area or shield the press to minimize danger to others.
- It is impossible for the manufacturer to provide practical "all-purpose" shielding because this is a general purpose press that can be used in many different ways. The owner of the press must provide shielding that is practical and necessary for each application. Some protection is provided by wrapping the piece in a protective blanket before applying pressure. (Protective blankets are offered in the OTC catalog.)
- Never exceed the rated capacity of the cylinder.
- Do not stress adapters beyond their capacities; adapters used with this press must have a maximum tonnage rating equal to or higher than the maximum tonnage rating of the press.
- Use only OTC approved adapters and accessories.
- Do not use a cylinder if its port threads are damaged or if the coupler is bent or damaged.
- Use only approved hydraulic fluid.
- Supply pump must have sufficient fluid to fully stroke cylinder.
- Inspect the cylinder before each use; do not use the cylinder if damaged, altered, or in poor condition.
- User must ensure that all safety related decals are maintained and replaced when they become difficult to read.

This press can exert an extremely high force at a moderate hydraulic pump pressure. If you have any questions concerning an application, or how much force is exerted at a given pressure, please contact Technical Services.

Assembly

1. Assemble the C-frame base to the C-frame with the clamps and cap screws as shown in Figure 1. The base can be assembled to position the press either vertically or horizontally. The base can be mounted to a bench if desired.
2. Thread the cylinder into the threaded end of the C-frame until the cylinder threads are flush with the bottom of the C-frame threaded hole (full thread engagement).
3. Thread the coupler into the cylinder port.
4. Place the adapter base into the bottom of the C-frame and secure in place with the socket head set screw.

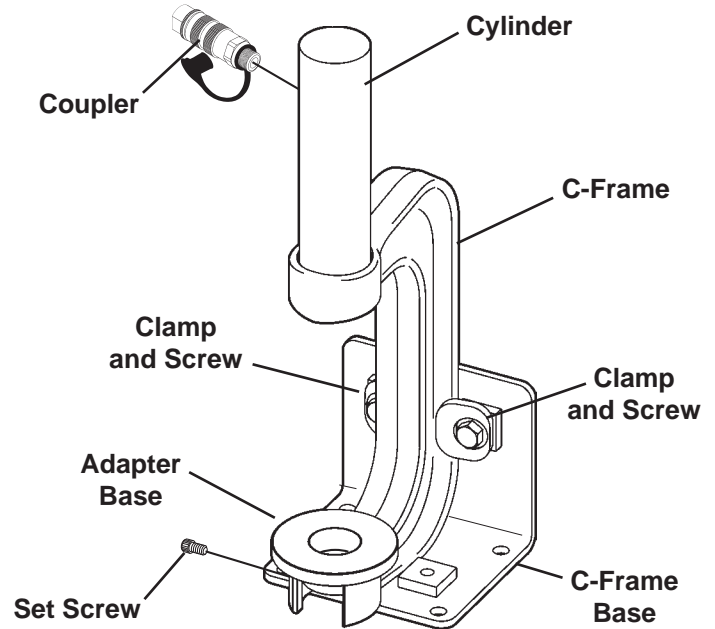

Figure 1

Operation

1. Choose the appropriate pressing adapter for the job and place it into the adapter base. See Figure 2.
2. Choose the appropriate pushing adapter and push the ball-detented end into the threaded hole of the cylinder's piston. See Figure 2.
3. Connect an oil line from the pump to the cylinder coupler.
4. Start the pump and move the pushing adapter toward the piece to be pressed. Stop before exerting pressure to the piece. Set up appropriate shielding or wrap the work with a protective blanket.
5. Continue operating the pump to finish the pressing job.
6. Release the pump pressure to allow the cylinder piston to retract.

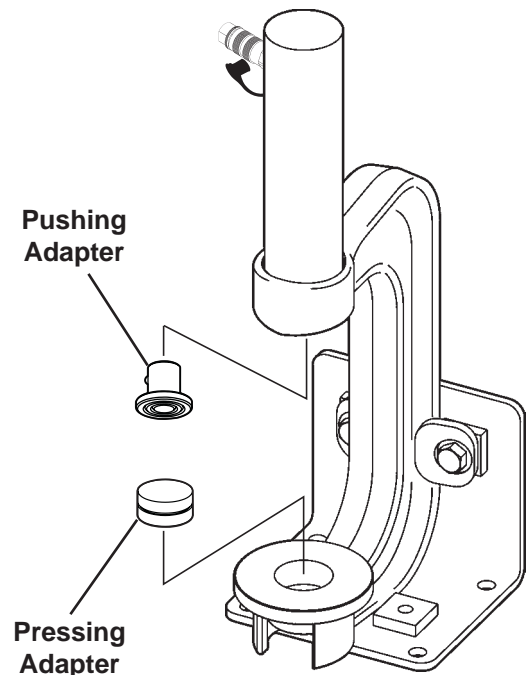

Figure 2

Parts List & Operating Instructions

Maintenance

Periodic Cleaning

1. Keep all hose connections and equipment attached to the cylinder as free of dirt and grime as possible. Seal all unused couplers with dust covers.
2. Use only approved hydraulic fluid and change as recommended, or sooner, if the fluid becomes contaminated.
3. Exposed threads (external or internal) must be cleaned and lubricated regularly, and protected from damage.
4. If the cylinder has been exposed to rain, snow, sand, grit-laden air, or any corrosive environment, it must be cleaned, lubricated, and protected immediately after exposure.

Storage

If the press is not to be used for a period of time, disassemble, clean and dry all components, plug cylinder port, and store in its original storage case. Store the case in a clean, dry area.

Hydraulic Cylinder

(used on No. 5180 Multipurpose Press)

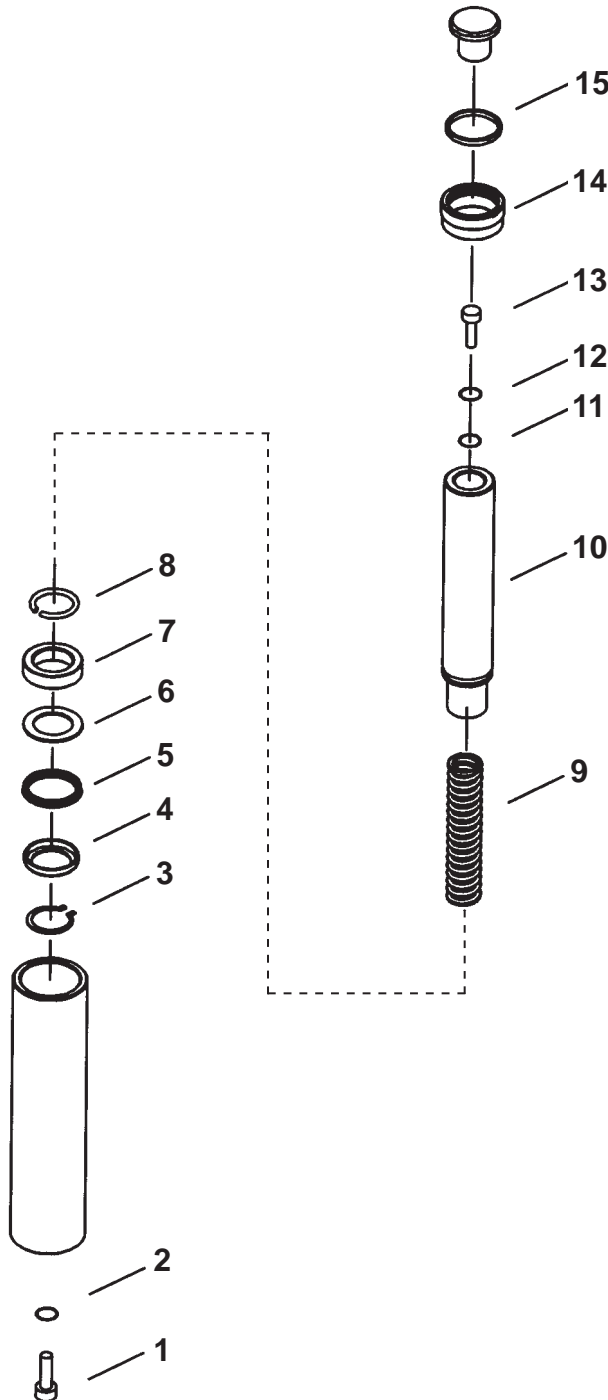

Cylinder Rebuild Kit No. 549507 includes:

Item No.	Description
1	Screw
2	Copper Washer
3	Ring
4	O-Ring
5	U-cup
6	Ring
7	Piston Ring
8	Ring
9	Spring
10	Piston
11	O-ring
12	Nylon Gasket
13	Screw
14	Retainer
15	Dust Ring

Cylinder Seal Kit No. 549508 includes:

Item No.	Description
4	O-ring
5	U-cup
6	Ring
15	Dust Ring