

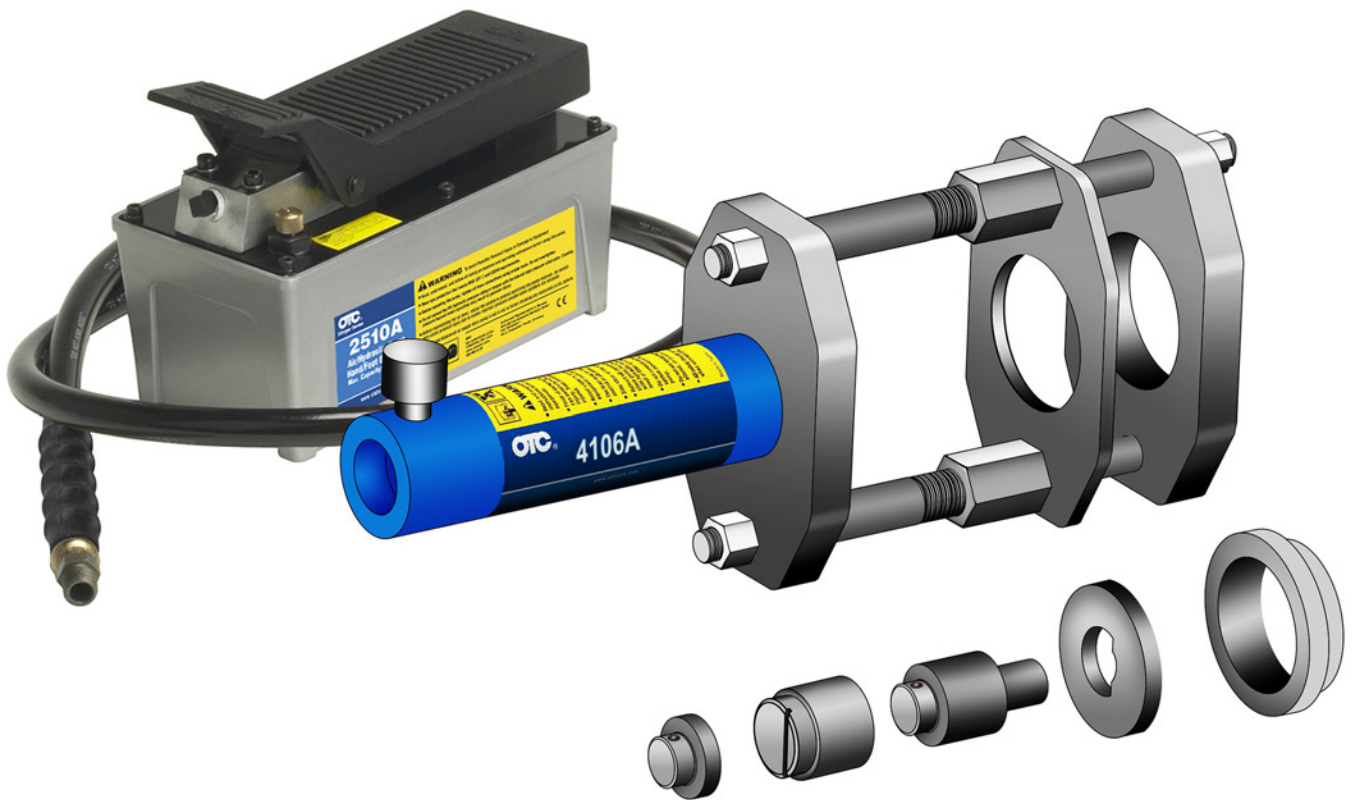

No. 4246 & No. 4247 Hendrickson Rear Suspension Bushing Tool

Applications: Hendrickson COMFORT AIR® Suspension
Hendrickson PRIMAAX® EX Suspension
Hendrickson V-RIDE™ Suspension



Explanation of Safety Signal Words

The safety signal word designates the degree or level of hazard seriousness.



DANGER: Indicates an imminently hazardous situation which, if not avoided, will result in death or serious injury.



WARNING: Indicates a potentially hazardous situation which, if not avoided, could result in death or serious injury.



CAUTION: Indicates a potentially hazardous situation which, if not avoided, may result in minor or moderate injury.

CAUTION: Used without the safety alert symbol indicates a potentially hazardous situation which, if not avoided, may result in property damage.

Safety Precautions



WARNING: To prevent personal injury and/ or property damage,



- Study, understand, and follow all safety precautions and operating instructions before using this Hendrickson Rear Suspension Bushing Tool. If the operator cannot read instructions, operating instructions and safety precautions must be read and discussed in the operator's native language.

- Only qualified operators may install, operate, adjust, maintain, clean, repair, inspect, or transport this suspension bushing tool.



- Wear eye protection that meets ANSI Z87.1, CE EN166, AS/NZS 1337, and OSHA standards.
- Do not use this suspension bushing tool for anything other than its intended purpose.
- No alteration shall be made to this product.
- Inspect the condition of the suspension bushing tool before each use; do not use if damaged, altered, or in poor condition.
- Use only those repair parts called out in the parts list in this document. Items found in the parts list have been carefully tested and selected by OTC.

Hose



- Before operating the pump, tighten all hose connections using the correct tools. Do not overtighten; connections need only be secure and leak-free. Overtightening can cause premature thread failure or high pressure fittings to split at pressures lower than their rated capacities.
- Should a hydraulic hose ever rupture, burst, or need to be disconnected, immediately shut OFF the pump, and open the control valve to release all pressure. NEVER grasp a leaking, pressurized hose with your hands; the force of escaping hydraulic fluid could cause serious injury.
- Do not subject the hose to any potential hazard such as fire, extreme cold or heat, sharp surfaces, or heavy impact. Do not allow the hose to kink, twist, curl, or bend so tightly that the fluid flow within the hose is blocked or reduced. Do not use the hose to move attached equipment. Periodically inspect the hose for wear, because any of these conditions can damage the hose and result in personal injury.
- Hose material and coupler seals must be compatible with the hydraulic fluid used. Hoses also must not come in contact with corrosive materials, such as creosote-impregnated objects and some paints. Consult the manufacturer before painting a hose. Never paint couplers. Hose deterioration due to corrosive material can result in personal injury.





Pump

- Do not exceed the maximum capacity of the pump or tamper with the internal high pressure relief valve. Creating pressure beyond the rated capacity can result in personal injury.
- Completely retract the cylinder before opening the filler screw on the pump to add hydraulic fluid. An overfill can cause personal injury due to excess reservoir pressure created when cylinders are retracted.

Cylinder

- Do not exceed the maximum capacity of the cylinder. Creating pressure beyond the rated capacity can result in personal injury.
- Adapters must be aligned and fully engaged so cylinder force is straight, avoiding an off-center load condition.

COMFORT AIR® – Pivot Bushing Removal

COMFORT AIR®		575164 Saddle	575163 Adapter Pin	576421 D-Pin Adapter	575165 Bushing Support	575167 Alignment Tool
						
Pivot Bushing	Remove		✓	✓		✓
	Install		✓			✓

Pivot Bushing Removal

1. Insert the *adapter pin* through the *alignment tool* and into the pivot bushing hole as shown in Figure 1.
2. Place the *clamping plate* over the alignment tool.
3. Assemble the *clamping nuts* to the *threaded rods*.
4. Insert a threaded rod through the upper holes in the clamping plate and the head plate. Install a *hex nut* on the threaded rod, but do not tighten at this time.
5. Insert a threaded rod through the lower holes in the clamping plate and the head plate. Install a hex nut on the threaded rod, but do not tighten at this time.
6. Tighten the clamping nuts to the clamping plate. See Figure 2.
7. Remove the alignment tool and adapter pin.

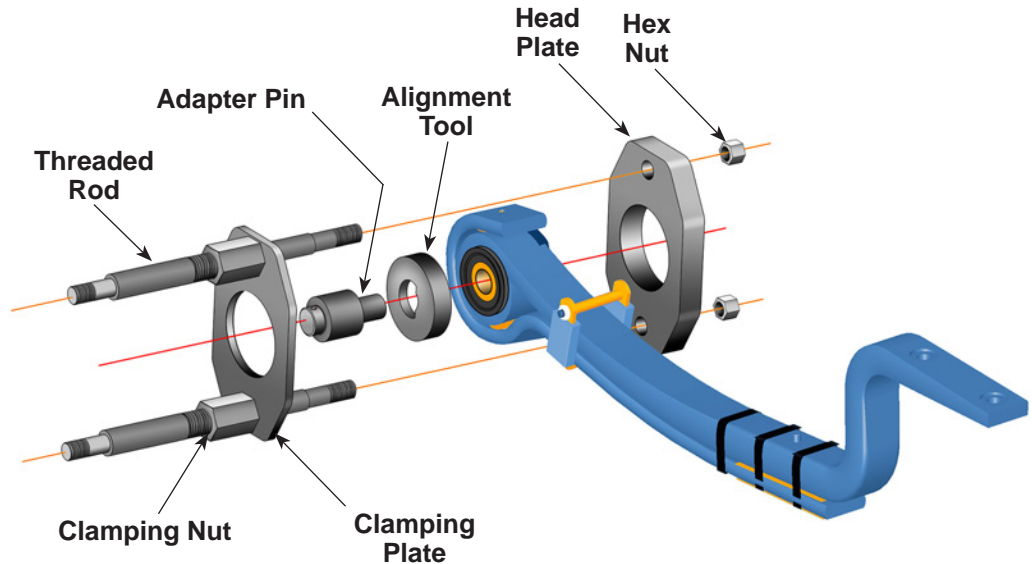

Figure 1

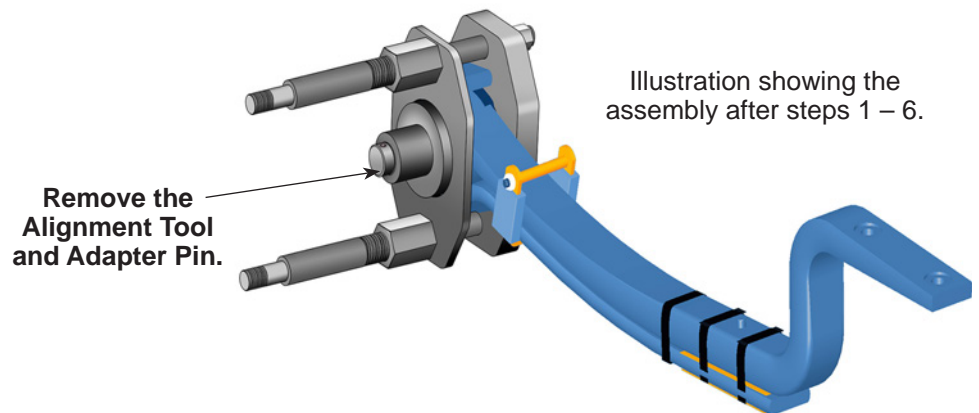
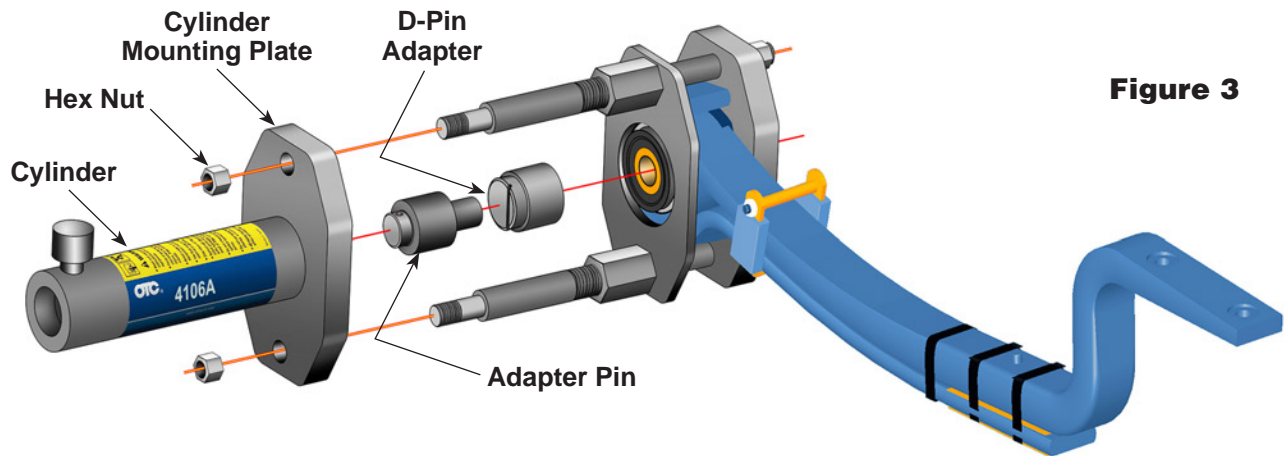

Figure 2

COMFORT AIR® – Pivot Bushing Removal



Pivot Bushing Removal contd.

8. Thread the cylinder into the *cylinder mounting plate*. See Figure 3.

⚠ WARNING: To prevent personal injury, the cylinder must be fully threaded into the cylinder mounting plate.

9. Install the cylinder mounting plate onto the end of the threaded rods. Adjust the clamping nuts as needed to fit the threaded rods through the holes in the cylinder mounting plate. Assemble the hex nuts on the threaded rods. Tighten the hex nuts on both ends of the threaded rods.

10. Hold the *D-pin adapter* over the pivot bushing until contact is made with the *adapter pin*.

11. Insert the adapter pin into the head of the cylinder.

12. Prepare the hydraulic pump for use by following the instructions provided with the pump regarding hookup, venting, priming, and operation.

⚠ WARNING: To prevent personal injury, pump capacity must not exceed 10,000 psi.

13. Connect the hydraulic hose from the hydraulic pump to the cylinder.

14. Operate the pump to extend the cylinder piston and apply pressure to push the pivot bushing out of the beam.



⚠ WARNING: To prevent personal injury from possible breakage under pressure, do not stand in the vicinity of the tool while the pivot bushing is being extracted. It is especially important to not stand in the direction of the hydraulic force.

COMFORT AIR® – Pivot Bushing Installation

Figure 4

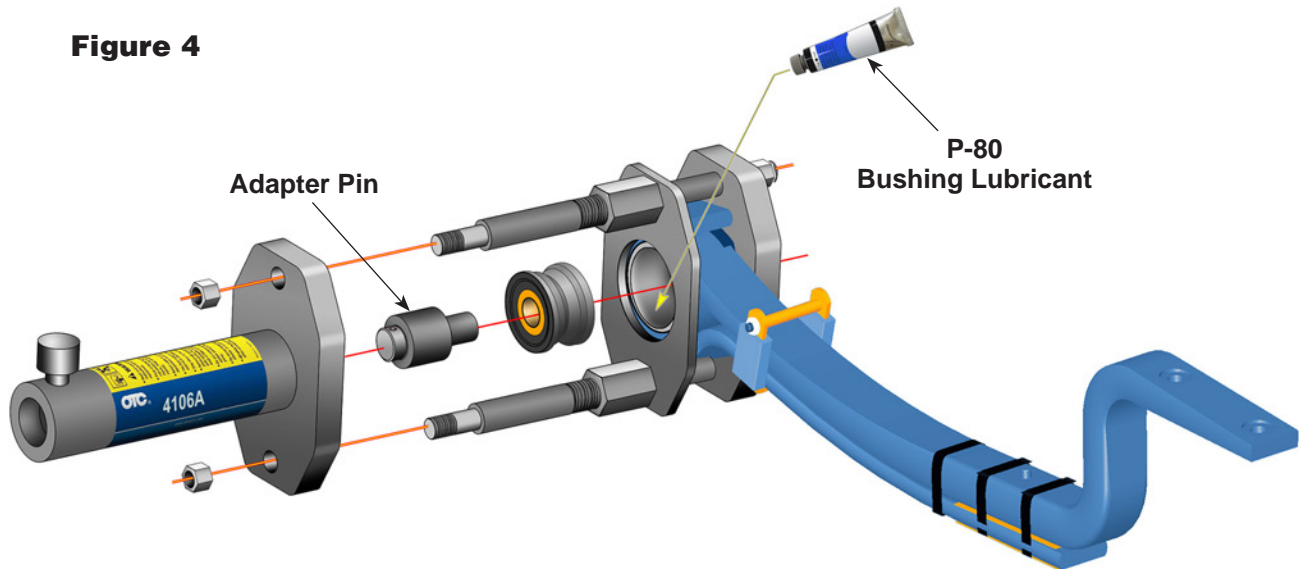

Pivot Bushing Installation

1. Clean and thoroughly lubricate the entire surface of the inside diameter of the beam and the outer diameter of the bushing. See Figure 4.
2. Insert the adapter pin into the head of the cylinder.
3. Place the pivot bushing on the end of the adapter pin as shown in Figure 4.
4. Operate the pump to extend the cylinder piston and apply enough pressure to hold the tool and components. Check the alignment of the pivot bushing.





⚠ WARNING: To prevent personal injury, pump capacity must not exceed 10,000 psi.

5. Operate the pump to apply pressure to install the pivot bushing completely into the beam.



⚠ WARNING: To prevent personal injury from possible breakage under pressure, do not stand in the vicinity of the tool while the pivot bushing is being installed. It is especially important to not stand in the direction of the hydraulic force.

PRIMAAX® EX – D-Pin Removal

PRIMAAX® EX		575164 Saddle	575163 Adapter Pin	576421 D-Pin Adapter	575165 Bushing Support	575167 Alignment Tool
						
D-Pin (52K or 46K)	Remove		✓	✓		✓
	Install	✓		✓		✓

D-Pin Removal

1. Mark the beam to show the alignment of the existing D-pin. Install the alignment tool over the D-pin, and place the clamping plate over the alignment tool. See Figure 5.
2. Assemble the clamping nuts to the threaded rods.
3. Insert a threaded rod through the upper holes in the clamping plate and the head plate. Install a hex nut on the threaded rod, but do not tighten at this time.
4. Insert a threaded rod through the lower holes in the clamping plate and the head plate. Install a hex nut on the threaded rod, but do not tighten at this time.
5. Tighten the clamping nuts to the clamping plate. See Figure 6.
6. Remove the alignment tool.

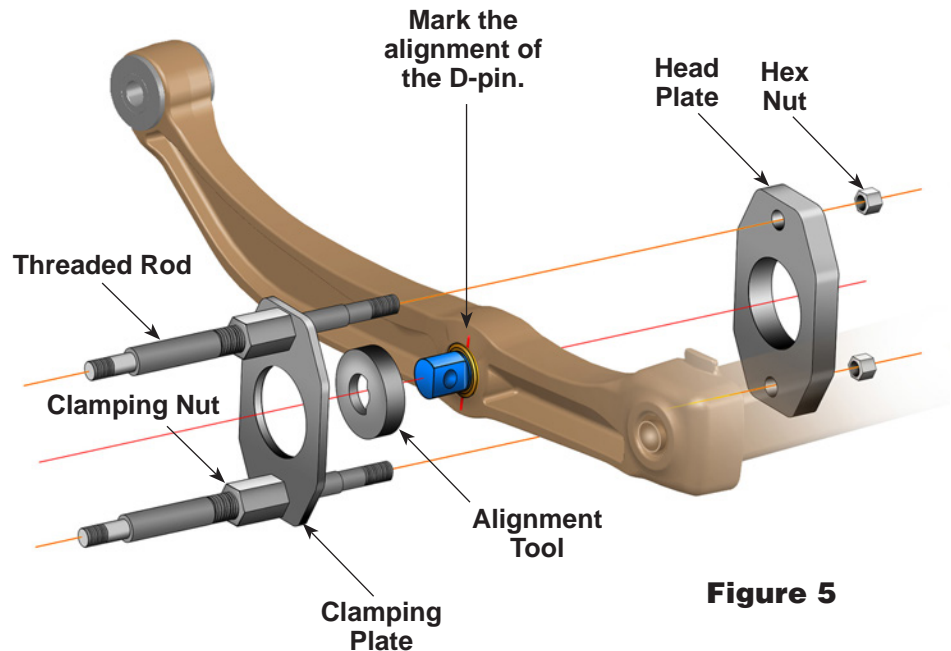

Figure 5

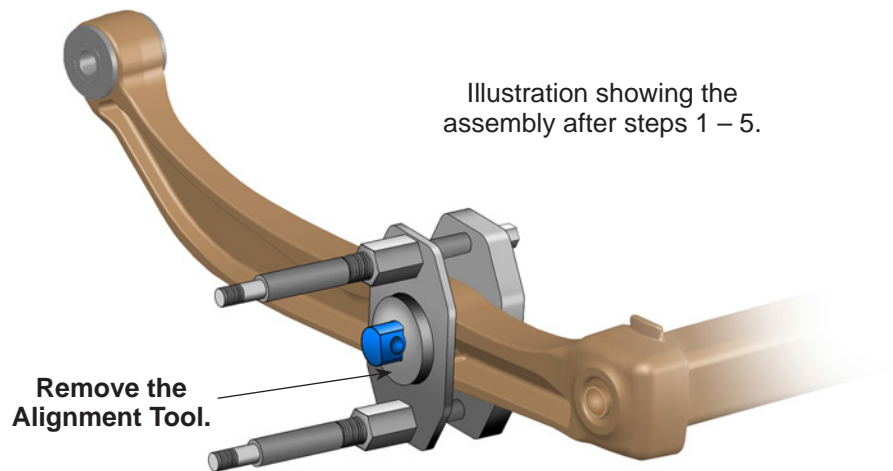
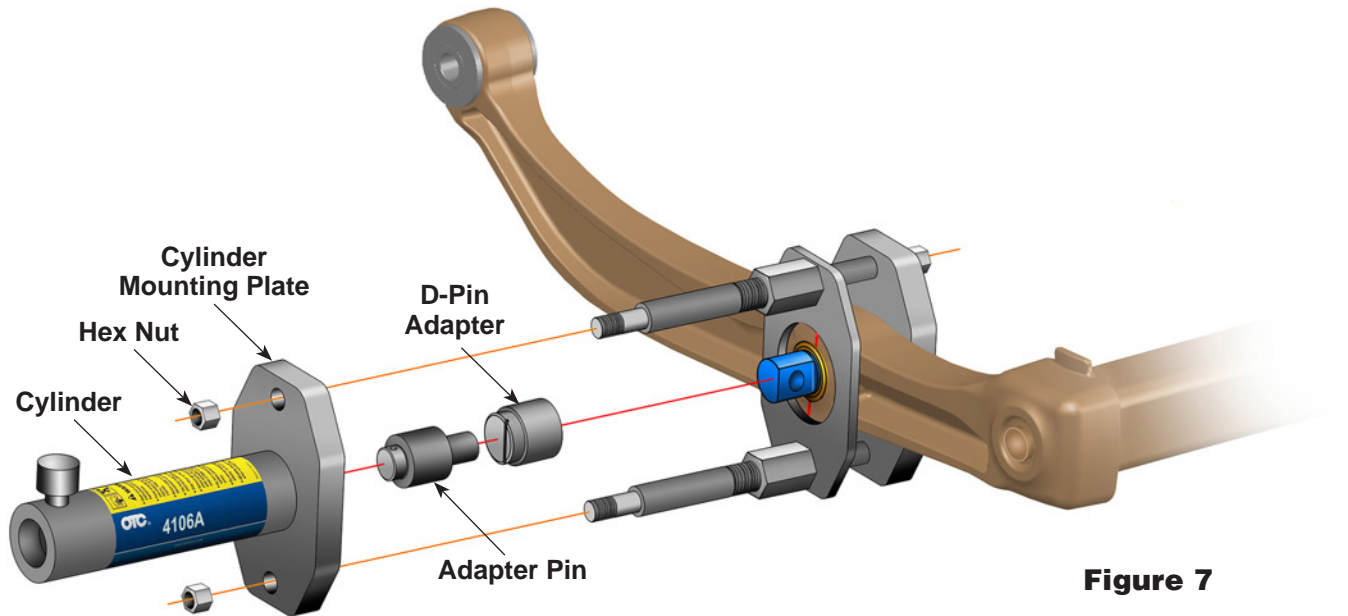

Figure 6

PRIMAAX® EX – D-Pin Removal



D-Pin Removal contd.

7. Thread the cylinder into the *cylinder mounting plate*. See Figure 7.

⚠ WARNING: To prevent personal injury, the cylinder must be fully threaded into the cylinder mounting plate.

8. Install the cylinder mounting plate onto the end of the threaded rods. Adjust the clamping nuts as needed to fit the threaded rods through the holes in the cylinder mounting plate. Assemble the hex nuts on the threaded rods. Tighten the hex nuts on both ends of the threaded rods.

9. Place the D-pin adapter over the D-pin.

10. Insert the adapter pin into the head of the cylinder.

11. Prepare the hydraulic pump for use by following the instructions provided with the pump regarding hookup, venting, priming, and operation.

⚠ WARNING: To prevent personal injury, pump capacity must not exceed 10,000 psi.

12. Connect the hydraulic hose from the hydraulic pump to the cylinder.

13. Operate the pump to extend the cylinder piston and apply pressure to push the D-pin out of the beam.



⚠ WARNING: To prevent personal injury from possible breakage under pressure, do not stand in the vicinity of the tool while the D-pin is being extracted. It is especially important to not stand in the direction of the hydraulic force.

PRIMAAX® EX – D-Pin Installation

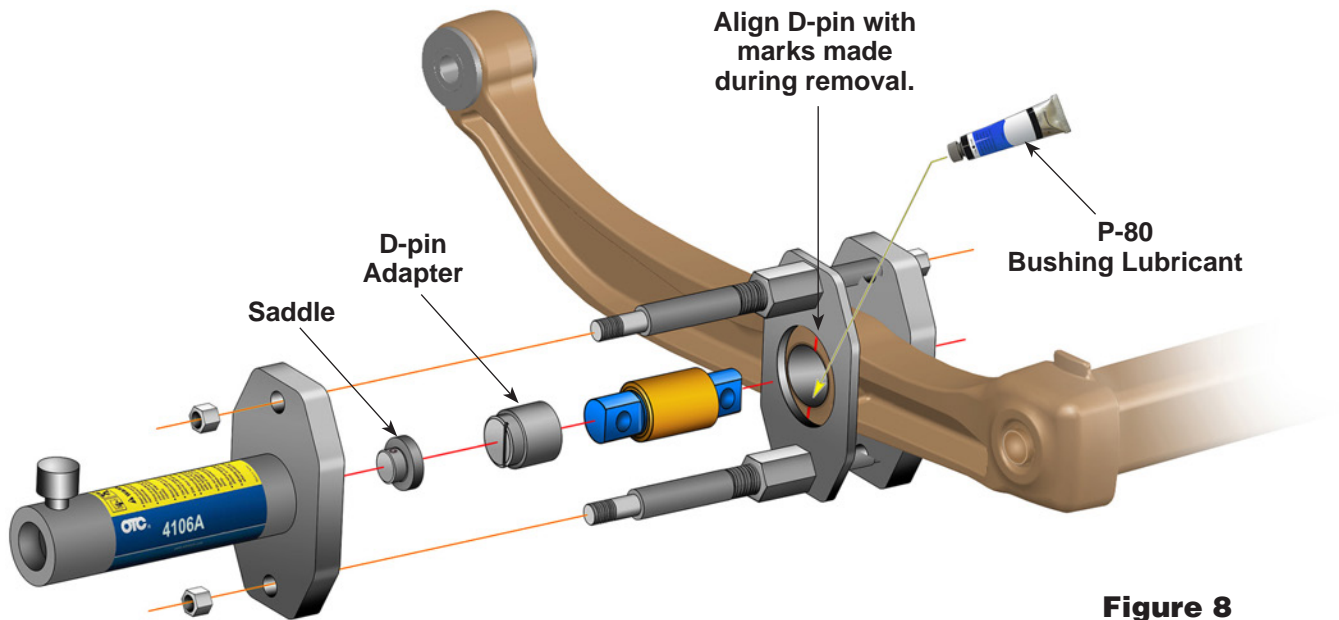

Figure 8

D-Pin Installation

1. Clean and thoroughly lubricate the entire surface of the inside diameter of the beam and outer bushing. See Figure 8.
2. Insert the *saddle* into the head of the cylinder.
3. Assemble the new D-pin and the *D-pin adapter* as shown. Align the line in the D-pin adapter with the alignment marks made during the removal procedure.
4. Operate the pump to extend the cylinder piston and apply enough pressure to hold the tool and components. Check the alignment of the D-pin. The centerline of the D-pin must be aligned with the centerline of the inside diameter of the beam.





⚠ WARNING: To prevent personal injury, pump capacity must not exceed 10,000 psi.

5. Operate the pump to apply pressure to install the D-pin completely into the beam. Confirm the D-pin is centered in the beam.



⚠ WARNING: To prevent personal injury from possible breakage under pressure, do not stand in the vicinity of the tool while the D-pin is being installed. It is especially important to not stand in the direction of the hydraulic force.

PRIMAAX® EX – Pivot Bushing Removal

PRIMAAX® EX		575164 Saddle	575163 Adapter Pin	576421 D-Pin Adapter	575165 Bushing Support	575167 Alignment Tool
						
Pivot Bushing	Remove		✓	✓	✓	✓
	Install		✓		✓	✓

Pivot Bushing Removal

1. Insert the adapter pin through the alignment tool and into the pivot bushing hole as shown in Figure 9.
2. Insert the bushing support over the pivot bushing.
3. Assemble the clamping nuts to the threaded rods.
4. Insert a threaded rod through the upper holes in the clamping plate and the head plate while positioning the head plate over the bushing support. Install a hex nut on the threaded rod, but do not tighten at this time.
5. Insert a threaded rod through the lower holes in the clamping plate and the head plate. Install a hex nut on the threaded rod, but do not tighten at this time.
6. Tighten the clamping nuts to the clamping plate. See Figure 10.
7. Remove the alignment tool and adapter pin.

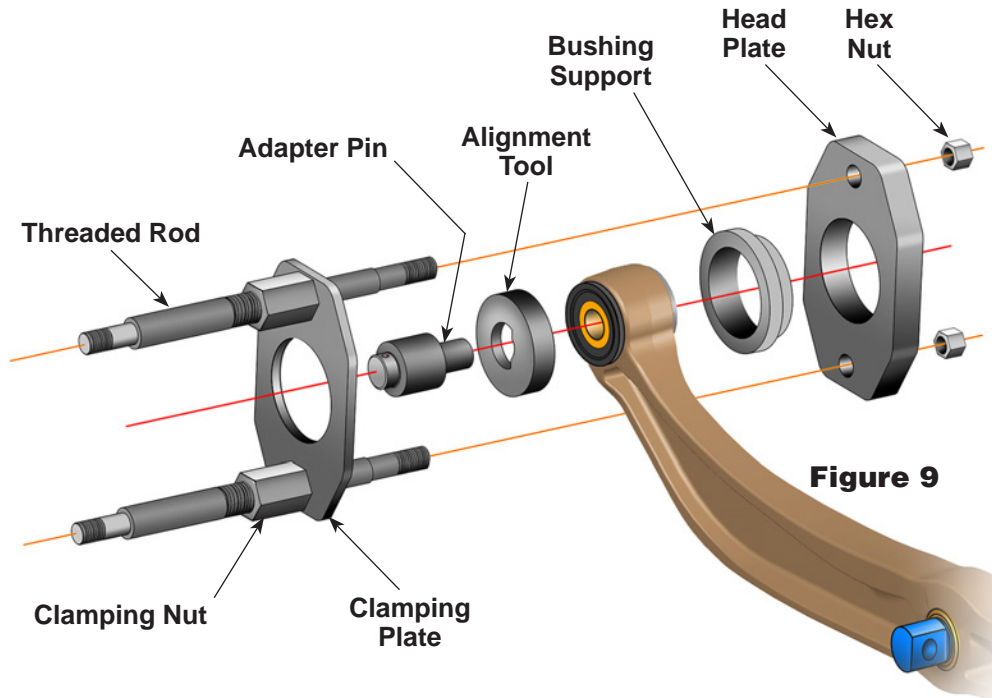

Figure 9

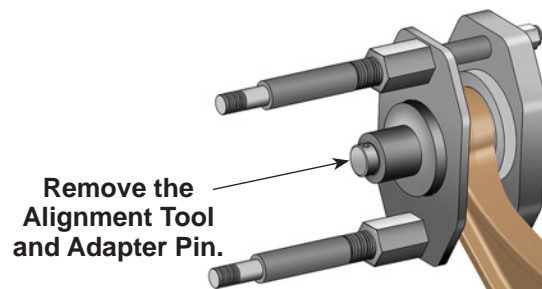
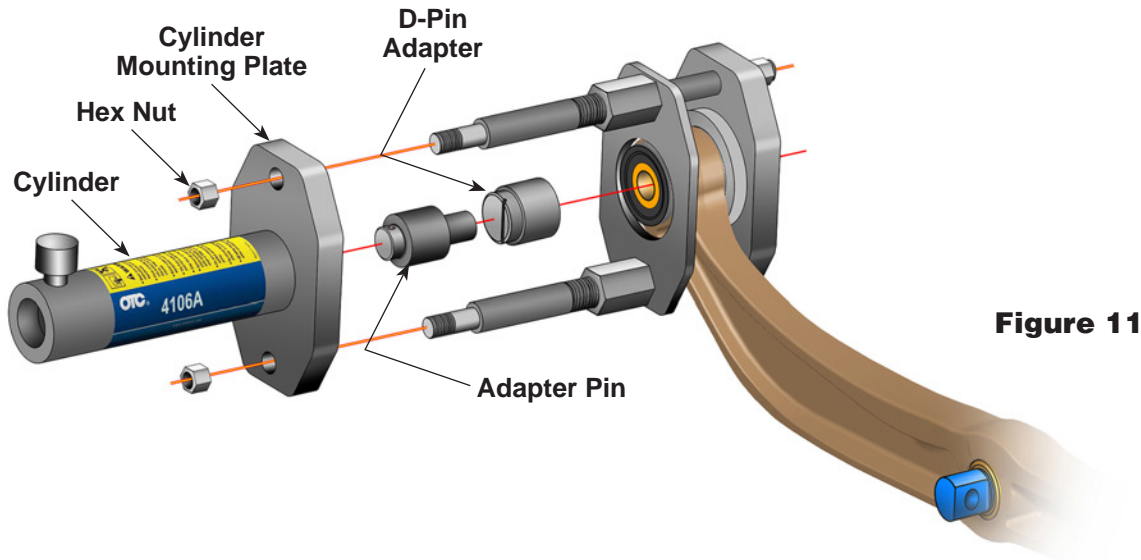

Illustration showing the assembly after steps 1 – 6.

Figure 10

PRIMAAX[®] EX – Pivot Bushing Removal



Pivot Bushing Removal contd.

8. Thread the cylinder into the cylinder mounting plate. See Figure 11.

⚠ WARNING: To prevent personal injury, the cylinder must be fully threaded into the cylinder mounting plate.

9. Install the cylinder mounting plate onto the end of the threaded rods. Adjust the clamping nuts as needed to fit the threaded rods through the holes in the cylinder mounting plate. Assemble the hex nuts on the threaded rods. Tighten the hex nuts on both ends of the threaded rods.
10. Hold the D-pin adapter over the pivot bushing until contact is made with the adapter pin.
11. Insert the adapter pin into the head of the cylinder.
12. Prepare the hydraulic pump for use by following the instructions provided with the pump regarding hookup, venting, priming, and operation.

⚠ WARNING: To prevent personal injury, pump capacity must not exceed 10,000 psi.

13. Connect the hydraulic hose from the hydraulic pump to the cylinder.
14. Operate the pump to extend the cylinder piston and apply pressure to push the pivot bushing out of the beam.



⚠ WARNING: To prevent personal injury from possible breakage under pressure, do not stand in the vicinity of the tool while the pivot bushing is being extracted. It is especially important to not stand in the direction of the hydraulic force.

PRIMAAX® EX – Pivot Bushing Installation

Figure 12

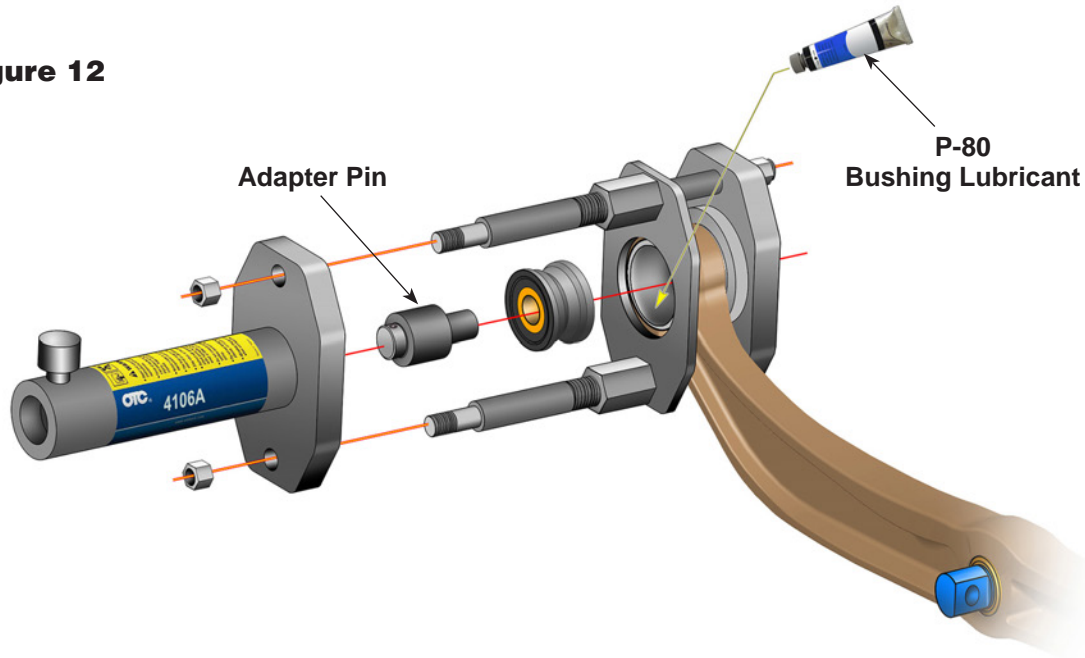

Pivot Bushing Installation

1. Clean and thoroughly lubricate the entire surface of the inside diameter of the beam and the outer diameter of the bushing. See Figure 12.
2. Insert the *adapter pin* into the head of the cylinder.
3. Place the pivot bushing on the end of the adapter pin as shown.
4. Operate the pump to extend the cylinder piston and apply enough pressure to hold the tool and components. Check the alignment of the pivot bushing.





⚠ WARNING: To prevent personal injury, pump capacity must not exceed 10,000 psi.

5. Operate the pump to apply pressure to install the pivot bushing completely into the beam.



⚠ WARNING: To prevent personal injury from possible breakage under pressure, do not stand in the vicinity of the tool while the pivot bushing is being installed. It is especially important to not stand in the direction of the hydraulic force.

V-RIDE™ – D-Pin Removal

V-Ride™		575164 Saddle	575163 Adapter Pin	576421 D-Pin Adapter	575165 Bushing Support	575167 Alignment Tool
						
D-Pin (52K or 46K)	Remove		✓	✓	✓	✓
	Install	✓		✓	✓	✓

D-Pin Removal

1. Mark the beam to show the alignment of the existing D-pin. Install the alignment tool over the D-pin, and place the clamping plate over the alignment tool. See Figure 13.
2. Insert the bushing support into the head plate.
3. Assemble the clamping nuts to the threaded rods.
4. Insert a threaded rod through the upper holes in the clamping plate and the head plate. Install a hex nut on the threaded rod, but do not tighten at this time.
5. Insert a threaded rod through the lower holes in the clamping plate and the head plate. Install a hex nut on the threaded rod, but do not tighten at this time.
6. Tighten the clamping nuts to the clamping plate. See Figure 14.
7. Remove the alignment tool.

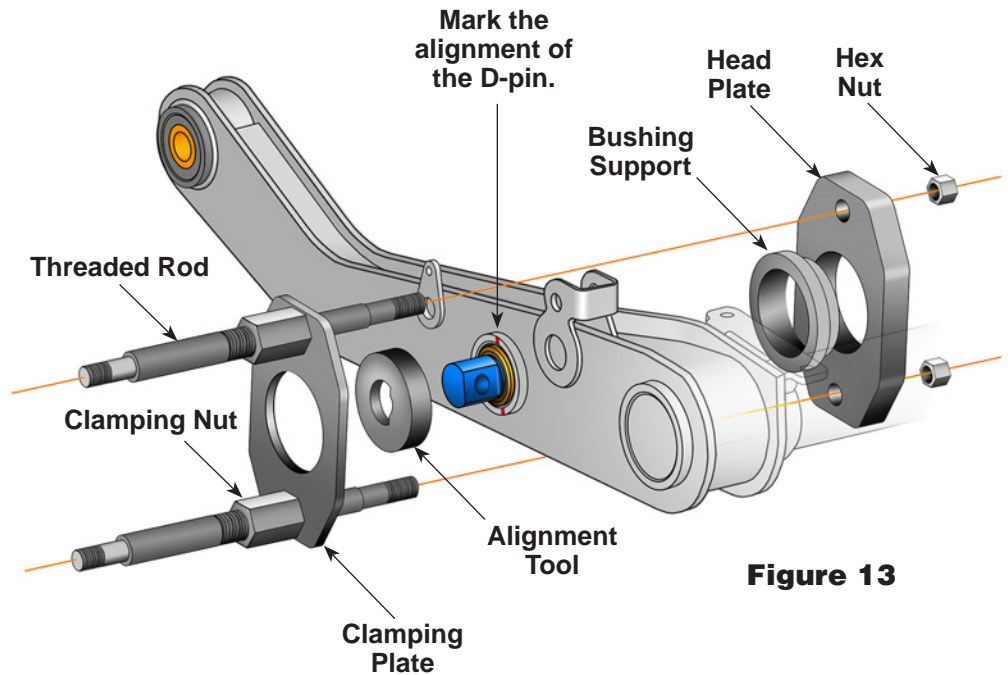

Figure 13

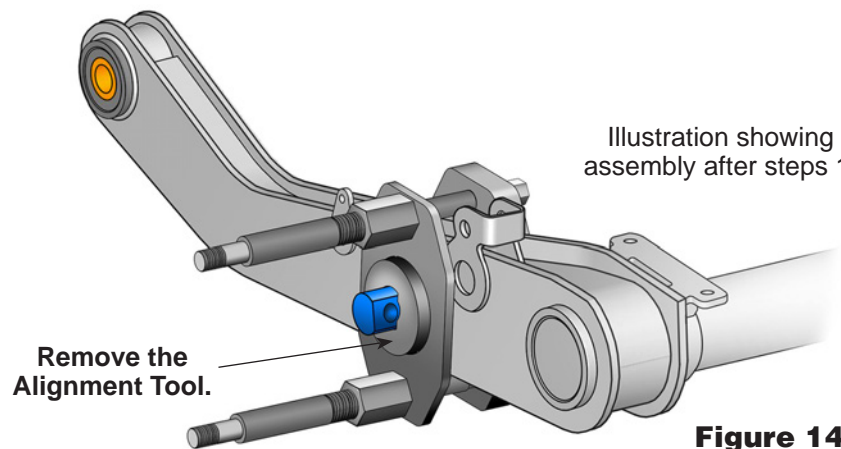

Figure 14

V-RIDE™ – D-Pin Removal

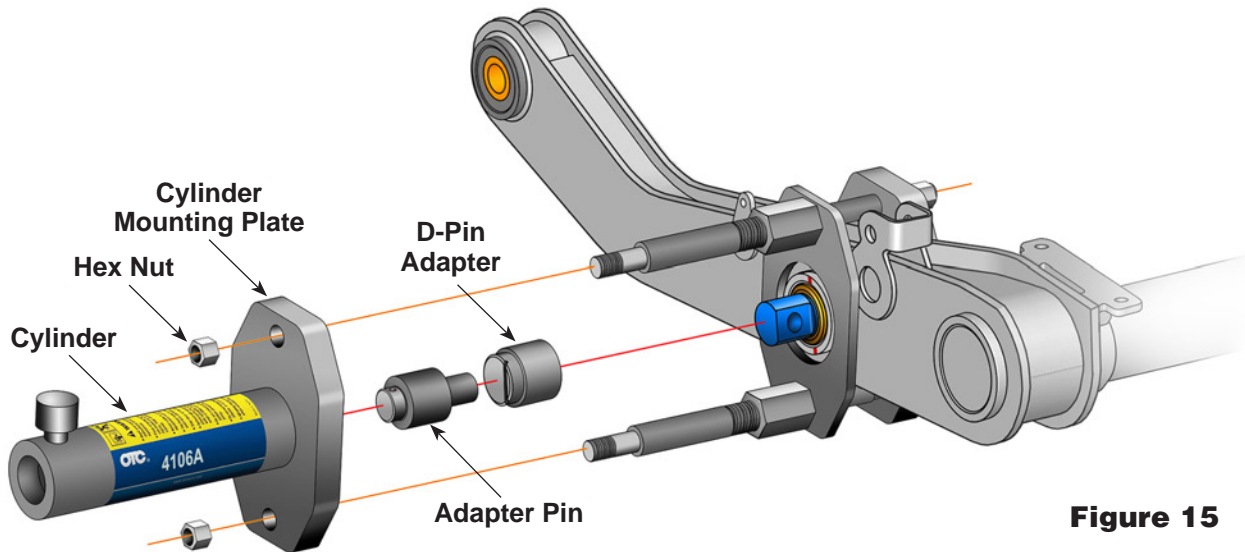

Figure 15

D-Pin Removal contd.

8. Thread the cylinder into the *cylinder mounting plate*. See Figure 15.

⚠ WARNING: To prevent personal injury, the cylinder must be fully threaded into the cylinder mounting plate.

9. Install the cylinder mounting plate onto the end of the threaded rods. Adjust the clamping nuts as needed to fit the threaded rods through the holes in the cylinder mounting plate. Assemble the hex nuts on the threaded rods. Tighten the hex nuts on both ends of the threaded rods.

10. Place the *D-pin adapter* over the D-pin.

11. Insert the *adapter pin* into the head of the cylinder.

12. Prepare the hydraulic pump for use by following the instructions provided with the pump regarding hookup, venting, priming, and operation.

⚠ WARNING: To prevent personal injury, pump capacity must not exceed 10,000 psi.

13. Connect the hydraulic hose from the hydraulic pump to the cylinder.

14. Operate the pump to extend the cylinder piston and apply pressure to push the D-pin out of the beam.



⚠ WARNING: To prevent personal injury from possible breakage under pressure, do not stand in the vicinity of the tool while the D-pin is being extracted. It is especially important to not stand in the direction of the hydraulic force.

V-RIDE™ – D-Pin Installation

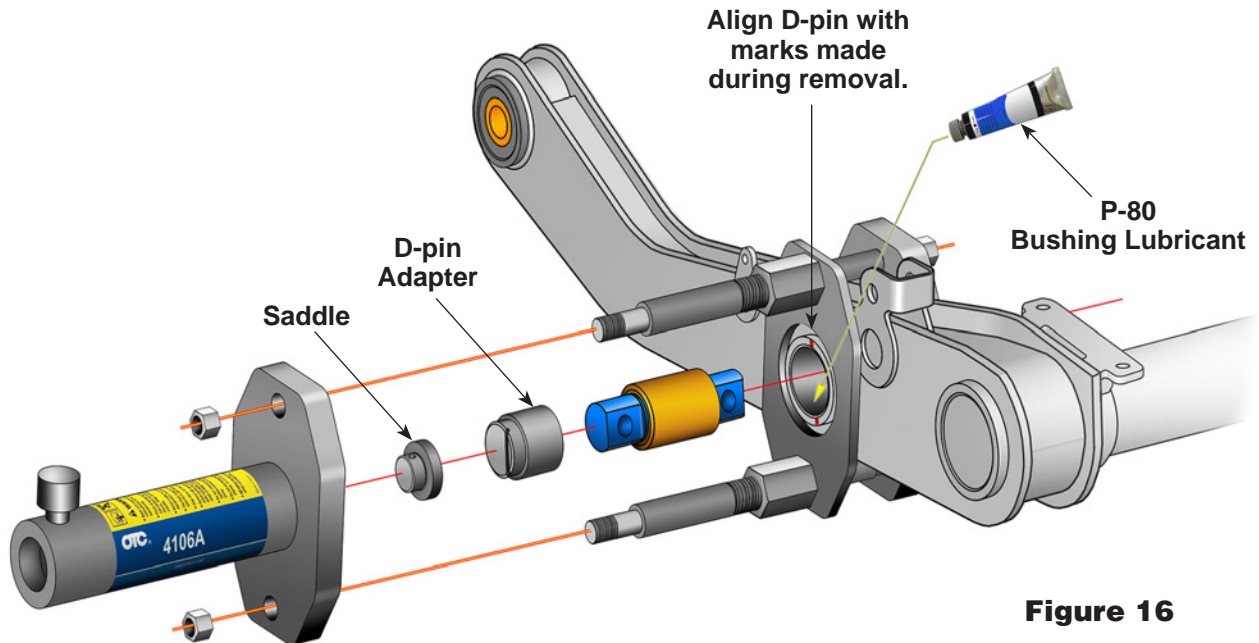

Figure 16

D-Pin Installation

1. Clean and thoroughly lubricate the entire surface of the inside diameter of the beam and outer bushing. See Figure 16.
2. Insert the *saddle* into the head of the cylinder.
3. Assemble the new D-pin and the *D-pin adapter* as shown. Align the line in the D-pin adapter with the alignment marks made during the removal procedure.
4. Operate the pump to extend the cylinder piston and apply enough pressure to hold the tool and components. Check the alignment of the D-pin. The centerline of the D-pin must be aligned with the centerline of the inside diameter of the beam.





⚠ WARNING: To prevent personal injury, pump capacity must not exceed 10,000 psi.

5. Operate the pump to apply pressure to install the D-Pin completely into the beam. Confirm the D-pin is centered in the beam.



⚠ WARNING: To prevent personal injury from possible breakage under pressure, do not stand in the vicinity of the tool while the D-pin is being installed. It is especially important to not stand in the direction of the hydraulic force.

V-RIDE™ – Pivot Bushing Removal

V-Ride™		575164 Saddle	575163 Adapter Pin	576421 D-Pin Adapter	575165 Bushing Support	575167 Alignment Tool
						
Pivot Bushing	Remove		✓	✓		✓
	Install		✓			✓

Pivot Bushing Removal

1. Insert the *adapter pin* through the *alignment tool* and into the pivot bushing hole as shown in Figure 17.
2. Assemble the *clamping nuts* to the *threaded rods*.
3. Insert a threaded rod through the upper holes in the clamping plate and the head plate. Install a *hex nut* on the threaded rod, but do not tighten at this time.
4. Insert a threaded rod through the lower holes in the clamping plate and the head plate. Install a hex nut on the threaded rod, but do not tighten at this time.
5. Tighten the clamping nuts to the clamping plate. See Figure 18.
6. Remove the alignment tool and adapter pin.

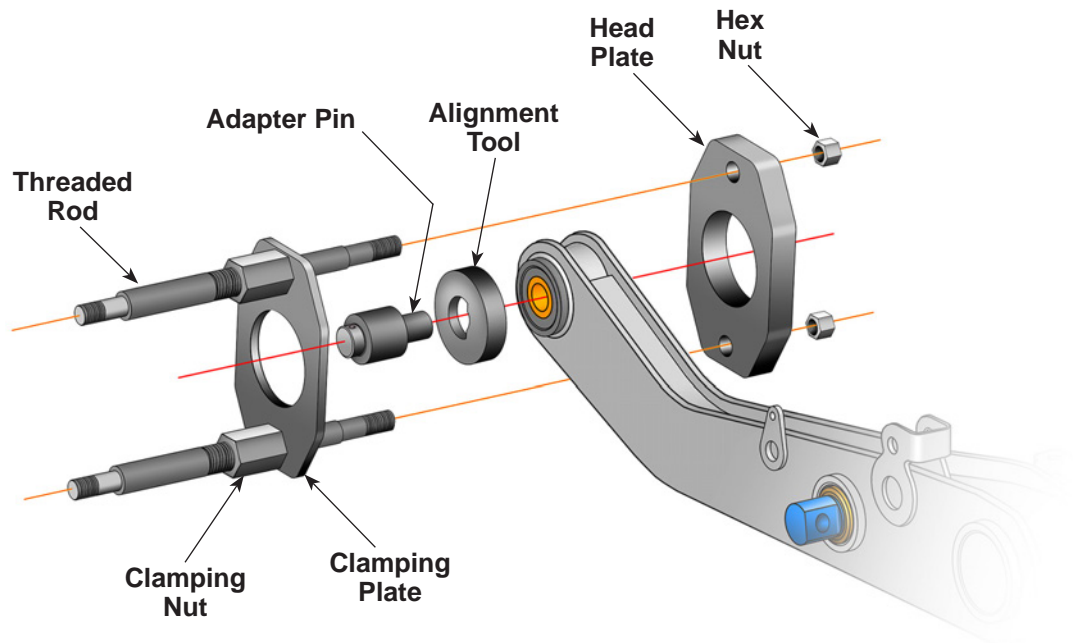

Figure 17

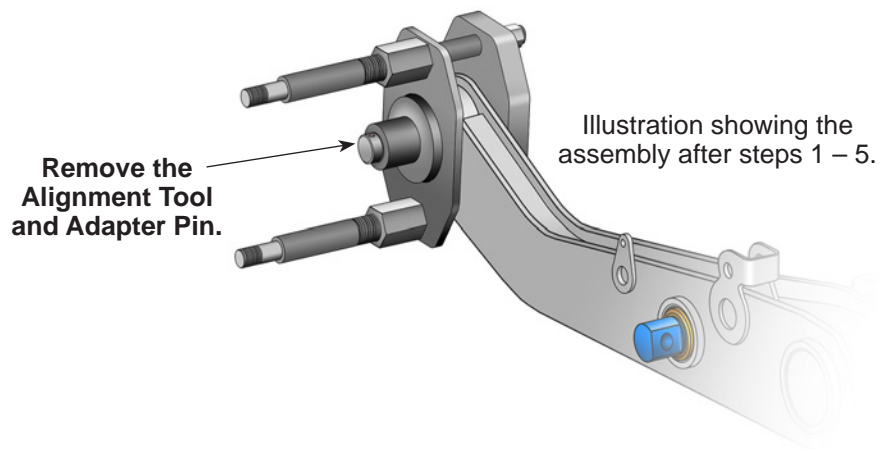
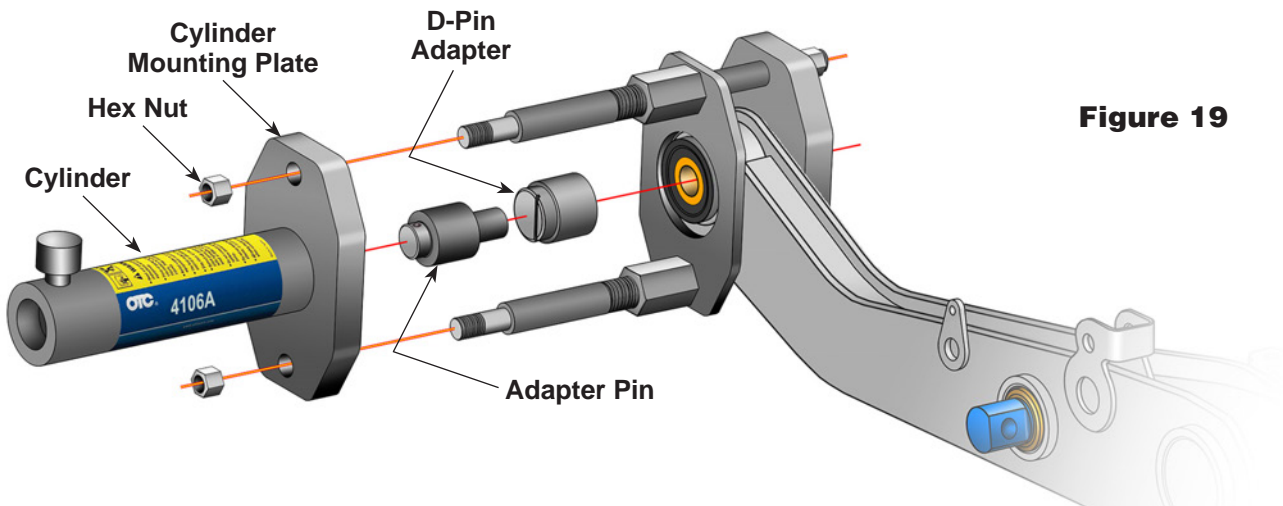

Figure 18

V-RIDE™ – Pivot Bushing Removal



Pivot Bushing Removal contd.

7. Thread the cylinder into the *cylinder mounting plate*. See Figure 19.

⚠ WARNING: To prevent personal injury, the cylinder must be fully threaded into the cylinder mounting plate.

8. Install the cylinder mounting plate onto the end of the threaded rods. Adjust the clamping nuts as needed to fit the threaded rods through the holes in the cylinder mounting plate. Assemble the hex nuts on the threaded rods. Tighten the hex nuts on both ends of the threaded rods.

9. Hold the *D-pin adapter* over the pivot bushing until contact is made with the *adapter pin*.

10. Insert the adapter pin into the head of the cylinder.

11. Prepare the hydraulic pump for use by following the instructions provided with the pump regarding hookup, venting, priming, and operation.

⚠ WARNING: To prevent personal injury, pump capacity must not exceed 10,000 psi.

12. Connect the hydraulic hose from the hydraulic pump to the cylinder.

13. Operate the pump to extend the cylinder piston and apply pressure to push the pivot bushing out of the beam.

⚠ WARNING: To prevent personal injury from possible breakage under pressure, do not stand in the vicinity of the tool while the pivot bushing is being extracted. It is especially important to not stand in the direction of the hydraulic force.



V-RIDE™ – Pivot Bushing Installation

Figure 20

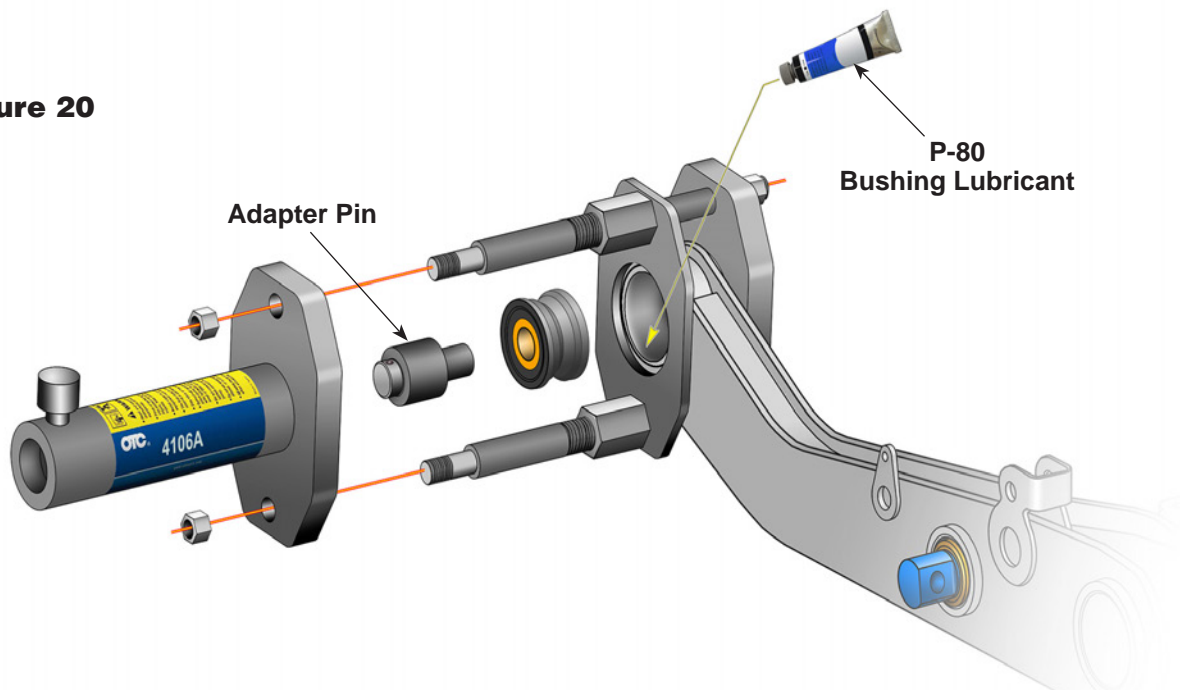

Pivot Bushing Installation

1. Clean and thoroughly lubricate the entire surface of the inside diameter of the beam and outer diameter of the bushing. See Figure 20.
2. Insert the *adapter pin* into the head of the cylinder.
3. Place the pivot bushing on the end of the adapter pin as shown.
4. Operate the pump to extend the cylinder piston and apply enough pressure to hold the tool and components. Check the alignment of the pivot bushing.

⚠ WARNING: To prevent personal injury, pump capacity must not exceed 10,000 psi.

5. Operate the pump to apply pressure to install the pivot bushing completely into the beam.



⚠ WARNING: To prevent personal injury from possible breakage under pressure, do not stand in the vicinity of the tool while the pivot bushing is being installed. It is especially important to not stand in the direction of the hydraulic force.

Parts List

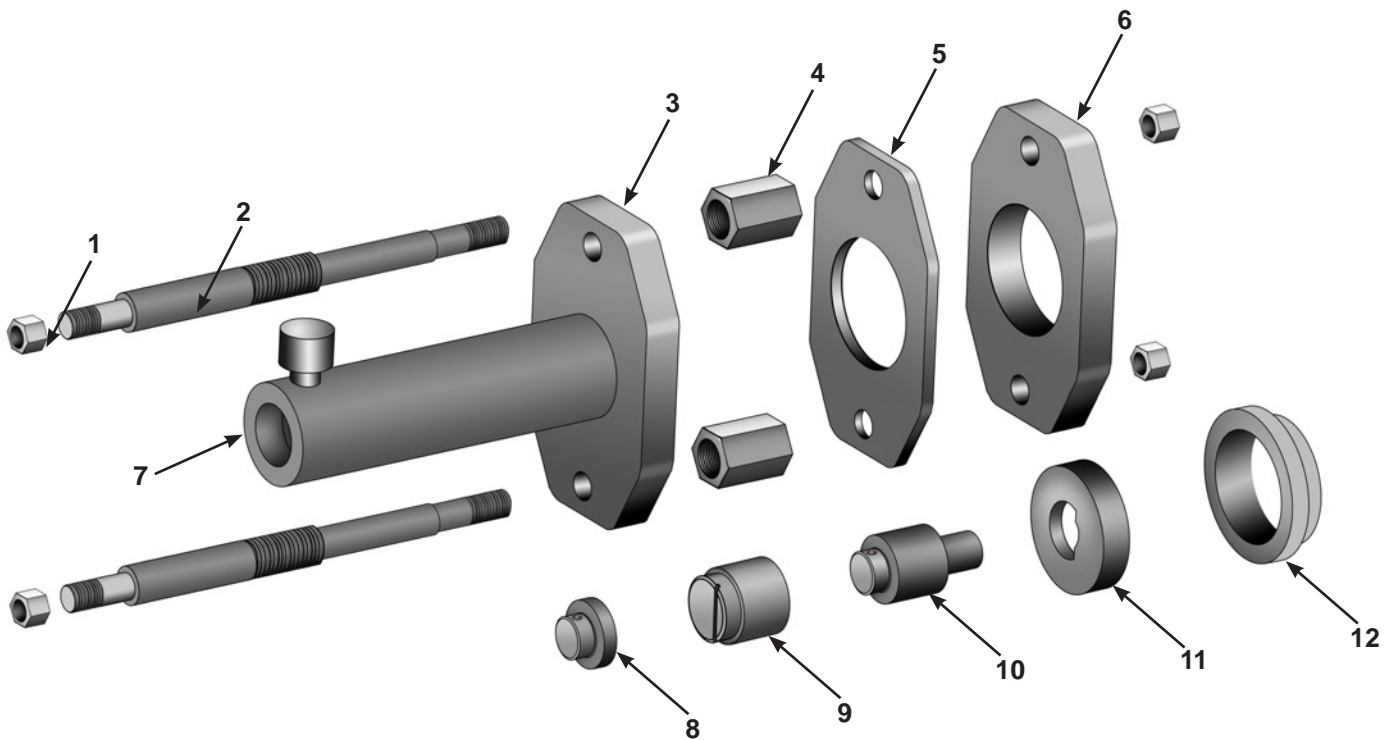

Item No.	Part No.	Qty.	Description
1	576924	1	Hex Nut Kit (<i>contains four nuts</i>)
2	575170	2	Threaded Rod
3	575173	1	Cylinder Mounting Plate
4	575169	2	Clamping Nut
5	575171	1	Clamping Plate
6	575172	1	Head Plate
7	4106A	1	Hydraulic Cylinder (<i>25 Ton</i>)
8	575164	1	Saddle
9	576421	1	D-Pin Adapter
10	575163	1	Adapter Pin
11	575167	1	Alignment Tool
12	575165	1	Bushing Support
	575166	1	Warning Decal (<i>not shown</i>)
	104031	1	Warranty / Authorized Service Center List (<i>not shown</i>)
	36886	1	Hose Assembly (<i>4247 only; not shown</i>)
	2510A	1	Air / Hydraulic Pump (<i>4247 only; not shown</i>)
	9798	1	Hose Half Coupler (<i>4247 only; not shown</i>)

Inspection and Maintenance



CAUTION: To prevent personal injury,

- Only qualified personnel shall perform inspections to this Hendrickson Rear Suspension Bushing Tool.
- Before each use, an approved inspector must inspect the suspension bushing tool for bends, cracks, dents, elongated holes, or missing hardware. If damage is found, discontinue use.
- Use only those repair parts called out in the parts list in this document. Items found in the parts list have been carefully tested and selected by OTC.

Maintenance

To prevent contamination from entering the hydraulic system and damaging the cylinder, keep the cylinder clean. When the cylinder is not in use, keep the piston rod fully retracted and stored upside down. Use protective covers on disconnected quick couplers.

Disposal

At the end of its useful life, dispose of the suspension bushing tool according to federal, state, and local regulations.