



Parts List for:

1857
1858
1858-1P
60534 (press frame only)

100 Ton Shop Press

Frame Assembly

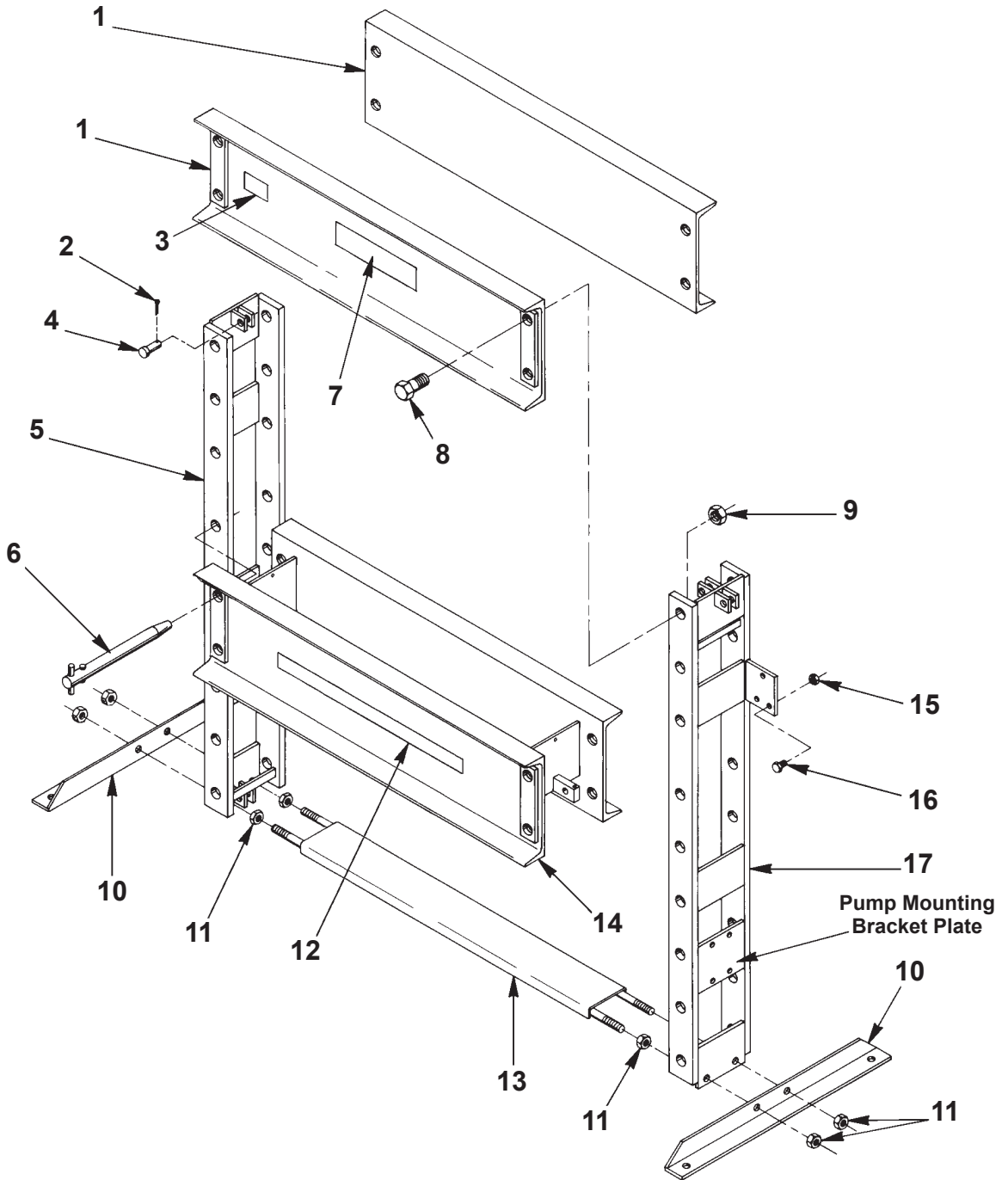

Item No.	Part No.	No. Req'd	Description
1	43148	2	Upper Bolster
2	10472	3	Cotter Pin ($\frac{1}{8}$ Dia. x 1 $\frac{1}{2}$ -in. Long)
3	206043	1	Instruction Decal
4	16654	3	Clevis Pin
5	51230	1	Upright, Left-Hand
6	38166	4	Cross Pin
7	11592	1	Trade Name Decal
8	204344	8	Special Cap Screw
9	10406	8	Hex Jam Nut (1 $\frac{1}{8}$ -12; Torque to 275/300 ft. lbs.)

Item No.	Part No.	No. Req'd	Description
10	25849	2	Foot Angle
11	10397	8	Hex Nut ($\frac{3}{4}$ -10)
12	46909	1	Warning Decal
13	43176	1	Upright Spacer
14	61144	1	Lower Bolster
15	10204	3	Hex Nut ($\frac{3}{8}$ -16)
16	10049	3	Hex Hd. Cap Screw ($\frac{3}{8}$ -16 x 1-in. Long)
17	51229	1	Upright, Right-Hand

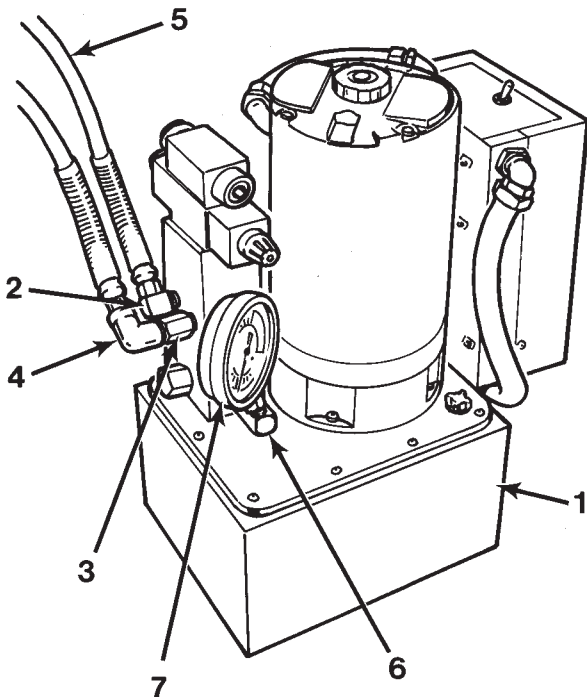

61217 and 4064 Electric Pump

Item No.	Part No.	No. Req'd	Description
1	61217	1	Electric Pump (Used on 1858)
	4064	1	Electric Pump (Used on 1858-1P)
2	10474	1	Elbow Fitting (90° x $\frac{3}{8}$ NPTF)
3	13828	1	Straight Fitting ($\frac{3}{8}$ NPTF)
4	10647	1	Elbow Fitting (90° x $\frac{3}{8}$ NPTF)
5	36888	2	Hyd. Hose, 10 ft.
6	10645	1	45° Street Elbow
7	10492	1	Gauge
	Not Shown		
	50931	1	Pump Mounting Bracket

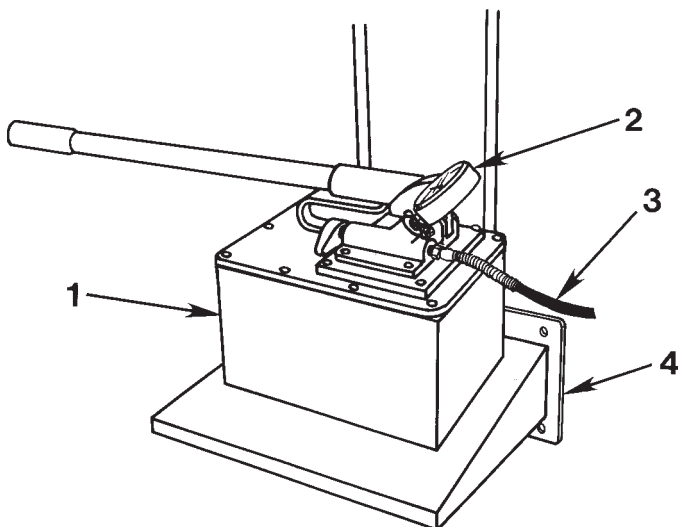

4008 Hand Pump

Item No.	Part No.	No. Req'd	Description
1	4008	1	Hand Pump (Used on 1857)
2	10492	1	Gauge
3	303840	1	Hyd. Hose, 10 ft.
4	50931	1	Pump Mounting Bracket

Cable Assembly

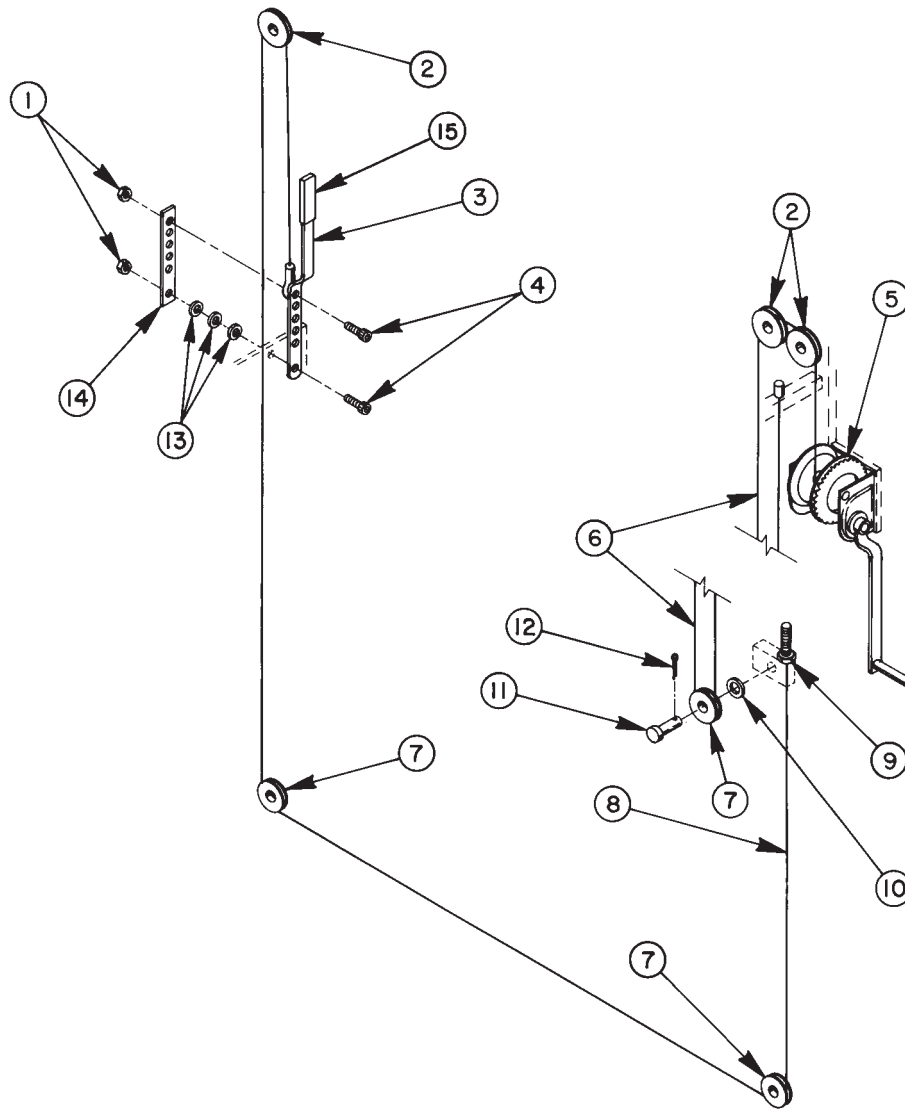

Item No.	Part No.	No. Req'd	Description	Item No.	Part No.	No. Req'd	Description
1	12809	2	Lock Nut (1/4-20)	8	38200	1	Press Cable
2	16659	3	Pulley (3-in. O.D.)	9	10204	1	Hex Nut (3/8-16)
3	38579	1	Handle	10	12330	1	Washer
4	10020	2	Cap Screw (1/4-20 x 1 1/4-in. long)	11	16654	3	Clevis Pin
5	18895-1	1	Winch	12	10472	3	Cotter Pin
6	207043	1	Winch Cable	13	12719	3	Washer
7	16653	3	Pulley (2 1/2-in. O.D.)	14	201929	1	Cable Strap
				15	17241	1	Handle Grip

Cylinder Mounting Assembly

Single-Acting Cylinder

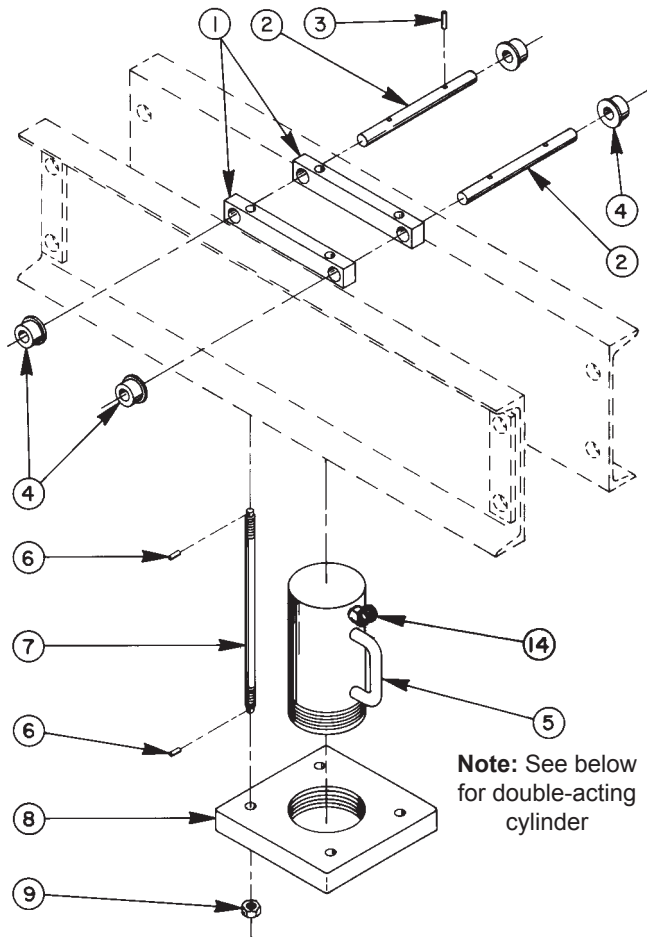

Note: See below for double-acting cylinder

Item No.	Part No.	No. Req'd	Description
1	44419	2	Bar
2	302551	2	Bar
3	10982	4	Slotted Spring Pin (1/4-in. dia. x 1 1/2-in. long)
4	206944	4	Roller
5	52434	1	Single-Acting Cylinder (Used on 1857; includes Item 14)
	51683	1	Double-Acting Cylinder (Used on 1858 and 1858-1P; includes Item 14)
6	10585	8	Roll Pin (1/4-in. dia. x 1-in. long)
7	302549	4	Threaded Rod
8	52451	1	Cylinder Mtg. Plate (Used on 1857)
	51786	1	Cylinder Mtg. Plate (Used on 1858 and 1858-1P)
9	10216	4	Hex Nut (3/4-10 UNC)
10	10204	2	Hex Nut (3/8-16)
11	50931	1	Pump Mounting Bracket
12	10052	2	Hex Hd. Cap Screw (3/8-16 x 1 1/4-in. long)
13	10798	4	Hex Hd. Cap Screw (1/2-20 x 3/4-in. long)
14	10648	1	45° Elbow Fitting (included with 52434 Single-Acting Cylinder)
		2	45° Elbow Fitting (included with 51683 Double-Acting Cylinder)

Double-Acting Cylinder

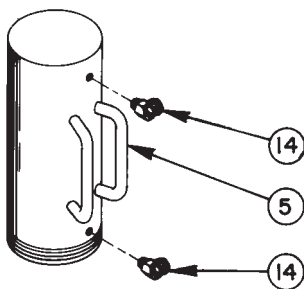

Pump Mounting Bracket

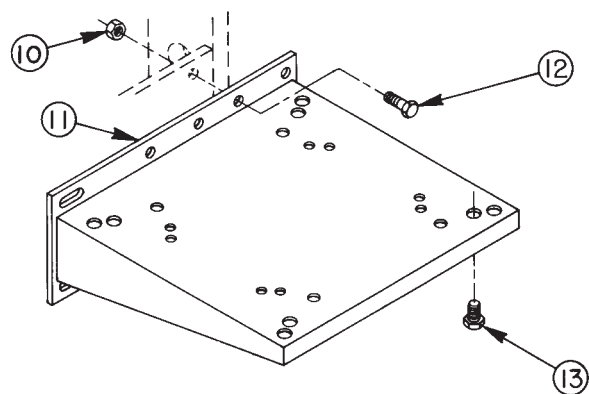

Refer to any operating instructions included with the product for detailed information about operation, testing, disassembly, reassembly, and preventive maintenance.

Items found in this parts list have been carefully tested and selected by OTC.

Therefore: Use only OTC replacement parts.

Additional questions can be directed to the OTC Technical Services Department.