



Assembly Instructions

for:

1857
1858
1858-1P
60534

100 Ton Shop Press

This heavy-duty press can handle difficult hydraulic pressing jobs. Wide-open uprights (over 12 in.) allow for easy side loading. The ram head glides smoothly along the upper bolster on rollers, allowing fast and easy horizontal adjustments. The upper bolster can be lowered eight inches for convenient positioning.

Safety Precautions

 **WARNING:** To prevent personal injury;

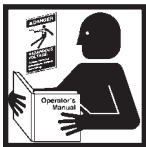

- Read and carefully follow the operating instructions and safety precautions for the press and cylinder. Most problems are caused by incorrect assembly or operation.
- The owner of the press must ensure the press is installed and operated according to Federal (OSHA), state, and local safety standards.

- A press can exert an extremely high force at a moderate hydraulic pump pressure. If you have any questions about how much force is exerted at a given pressure, contact Technical Services.
- This press is designed for shop maintenance applications. For use in other applications, contact Technical Services.

OPERATION



- Wear eye protection that meets the standards of ANSI Z87.1 and OSHA. Keep hands away from the work area. The press should be located in an isolated area or shielded to minimize danger to others. Hydraulic pressure can cause materials to break, possibly resulting in personal injury.



- It is impossible for the manufacturer to provide practical, all-purpose shielding because this is a general purpose press used in many different applications. The owner of the press must supply shielding (such as the 1230PB or 2036PB available through OTC) that is practical and specific for a particular application.

- A work piece must be well supported and aligned to prevent slippage and breakage.

- To prevent accidental slippage, do not place work piece on the press bed or apply hydraulic force until all bolster pins are in place and all tension has been removed from the bolster lift cables.

- Do not stress adapters beyond their capacities. Pushing or pulling adapters used with this press must have a maximum tonnage rating equal to, or greater than, the maximum tonnage rating of the press. Otherwise, breakage may occur.

- The user must ensure all safety-related decals are installed, maintained, and replaced when necessary.



- Keep hands, feet, legs, etc. out from under the bolster. Accidental slippage can result in personal injury.

Operating Instructions

Safety Precautions (cont'd)

Bolster Adjustment

 **WARNING** (cont'd)



- To prevent accidental cable breakage, never raise or lower the bolster if a load has been placed on it.
- When lowering the bolster, remove the work piece. Place one support pin all the way through each front and the back upright in the highest hole under the bolster that will not interfere with the new bolster position. Remove your hands from the support pins after the pins are in place.
- When raising the bolster, remove the work piece. Leave the support pins in place until the bolster is raised to its new position. Remove your hands from the support pins after the pins are in place.
- Inspect the entire length of the lifting cables at least every three months, and replace cables that appear frayed, worn, or crushed. The cables must run on the pulleys easily and the pulleys must be free to turn. Correct cable maintenance helps prevent cable breakage.

Assembly

Remove the shipping banding securing the press to the shipping pallet. Then remove all cartons and stand the press upright. Refer to the parts list (Form No. 100358) while performing the following assembly instructions.

1. Remove the lock ring and spring securing the winch handle to the winch axle. Then flip the handle 180° and reassemble the ring and spring.
2. Mount the pump mounting bracket to the right-hand upright using two hex head cap screws and nuts.
3. Place the pump on the mounting bracket. Thread four cap screws through the bottom of the bracket and into the pump reservoir.

CAUTION: Use a high-grade, non-hardening pipe sealant to seal all hydraulic connections. Teflon tape can be used if only ONE layer of tape is applied. Ensure the first thread is exposed without tape. Carefully apply the tape to prevent the tape from becoming pinched or broken off inside the hydraulic system. Loose pieces of tape can travel through a hydraulic system, which could potentially obstruct the flow of oil and damage the system.

4. Clean the threads on the hydraulic hose(s) and fittings. Assemble the hose(s) to the pump.
5. The gauge can be mounted to the gauge port with a 45° elbow as shown in Figure 1. The gauge can also be mounted at the cylinder by using a tee adapter between the swivel fitting and hose. If you are using a double-acting cylinder, install the gauge in the top swivel fitting. See Figure 2, at right. In either case, install a pipe plug in the pump's gauge port.
6. Thread the other end of the hose(s) into the swivel fitting(s) on the cylinder.

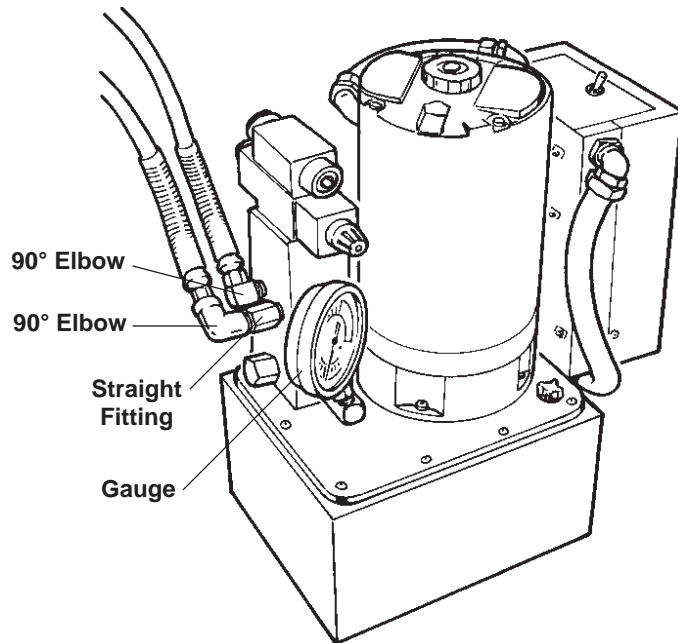

FIGURE 1

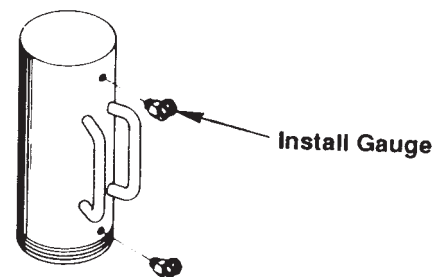

FIGURE 2

ASSEMBLY (cont'd)

7. Air can accumulate in the hydraulic system during initial setup or after prolonged use, causing the cylinder to respond slowly or in an unstable manner. To remove the air, first lay the cylinder on the floor. Then extend and retract the cylinder several times without putting a load on the system. Air will be released through the pump reservoir.
8. Position the work bed:
 - A. Put a small amount of tension on the cable by cranking the winch up, taking weight off the cross pins at the end of the bolster adjacent to the winch. Then pull the loose pins out of the bolster.
 - B. Raise the other end of the bolster by pulling slightly on the handle grip until the other two pins can be removed. Remove the pins.
 - C. Crank the winch for either up or down movement of the work bed and reinstall all pins.

CAUTION: The winch has a special friction brake for holding the bolster during positioning. The friction brake is NOT designed to hold during a pressing operation nor will it hold a workload during positioning.

9. The cylinder cannot be threaded into the movable head if the head is attached to the upper bolster. (The carrying handle of the cylinder will interfere with the bolster.)
 - A. Disconnect the hose(s) from the hydraulic cylinder. Insert a plug in the hose end(s) and cylinder's swivel fitting(s).
 - B. Remove the four roll pins and spacers connecting the cylinder mounting plate to the threaded rods of the cylinder mounting assembly. See Figure 3, below. Remove the mounting plate.
 - C. Thread the cylinder into the mounting plate. Position the cylinder so the coupler faces the side of the press where the pump is located. *NOTE: The cylinder handle must not interfere with the winch cable after the mounting plate and cylinder are installed.*

⚠ WARNING: To help prevent personal injury, the cylinder and mounting plate MUST have maximum thread engagement to prevent the threads from stripping while the press is under a full load.

- D. Due to the weight of the mounting plate and cylinder, the lower bolster can be used with cribbing to raise the mounting plate and cylinder into position under the top bolster.

CAUTION: The lower bolster shall be used in this manner during assembly only, when positioning the cylinder and mounting plate under the upper bolster. Using the lower bolster in this manner during normal operation with a full load can result in cable breakage and damage to the press.

- E. Fasten the mounting plate (with cylinder attached) to the threaded rods using the roll pins and spacers removed earlier in Step B. Then remove the cribbing and re-thread the hose(s) into the swivel fitting(s) on the cylinder.

Cylinder Mounting Assembly

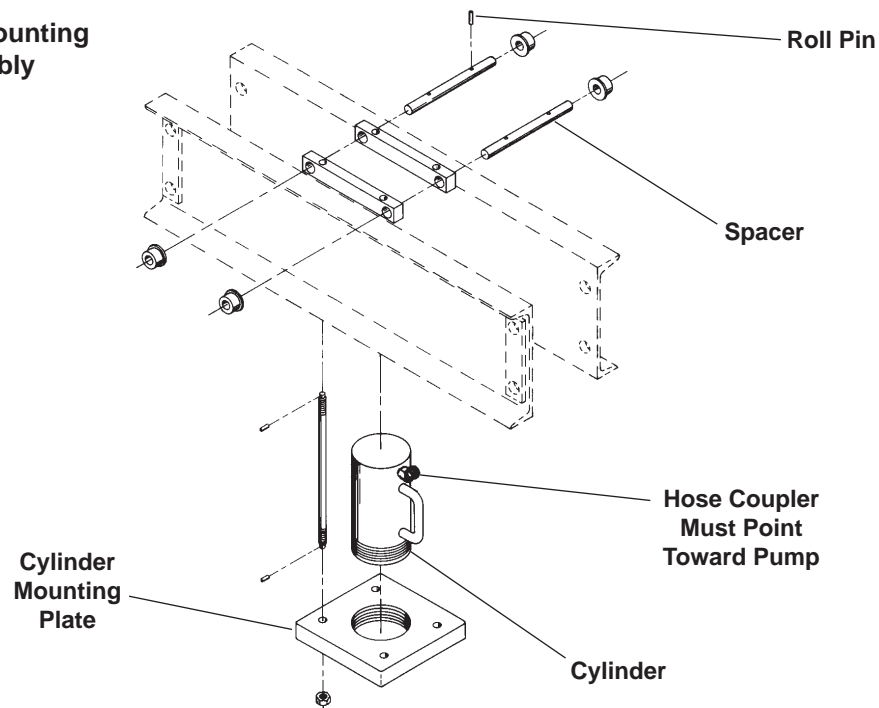

FIGURE 3



Parts List for:

1857

1858

1858-1P

60534 (press frame only)

100 Ton Shop Press

Frame Assembly

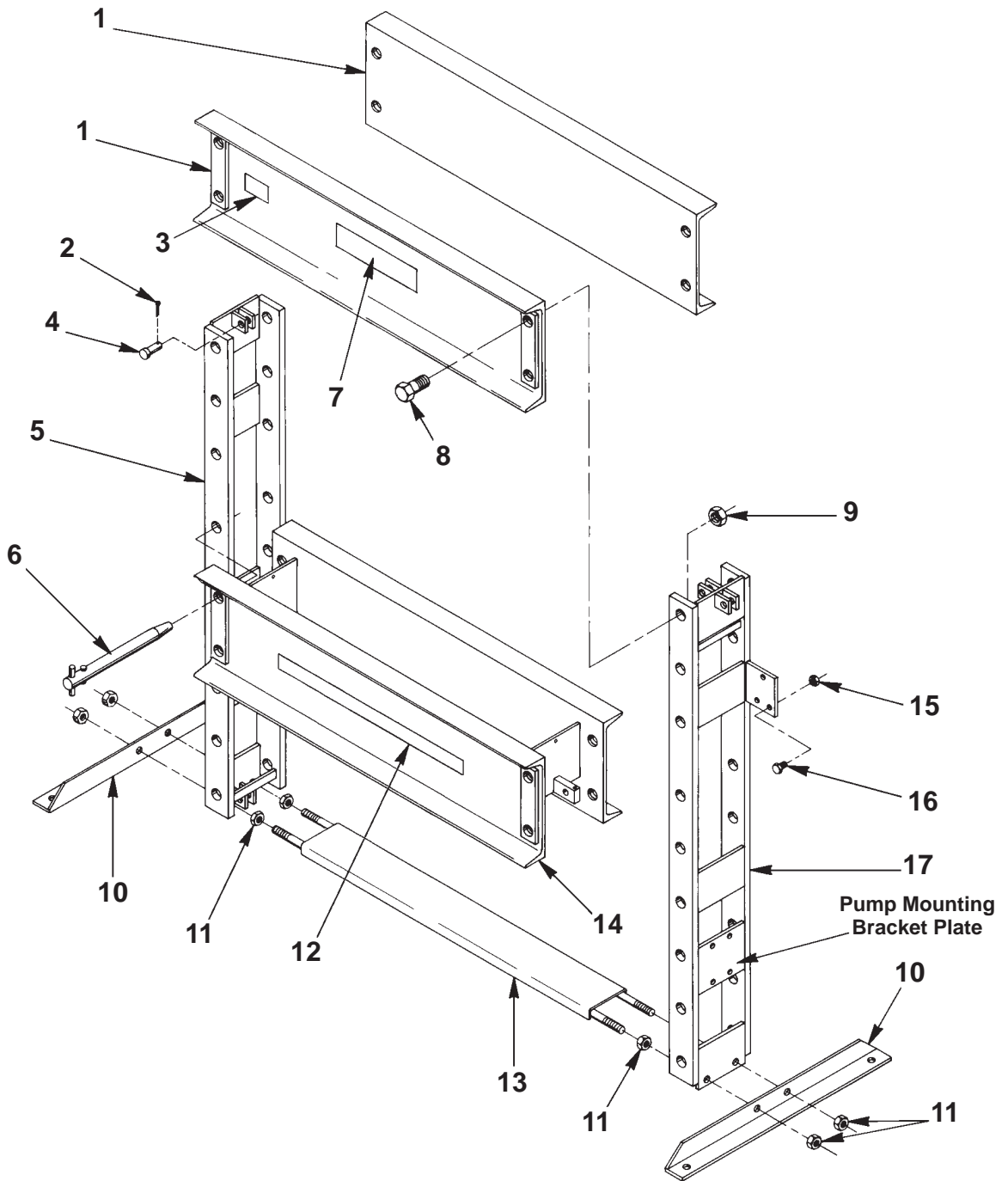

Parts List

Item No.	Part No.	No. Req'd	Description
1	43148	2	Upper Bolster
2	10472	3	Cotter Pin ($\frac{1}{8}$ Dia. x 1 $\frac{1}{2}$ -in. Long)
3	206043	1	Instruction Decal
4	16654	3	Clevis Pin
5	51230	1	Upright, Left-Hand
6	38166	4	Cross Pin
7	11592	1	Trade Name Decal
8	204344	8	Special Cap Screw
9	10406	8	Hex Jam Nut (1 $\frac{1}{8}$ -12; Torque to 275/300 ft. lbs.)

Item No.	Part No.	No. Req'd	Description
10	25849	2	Foot Angle
11	10397	8	Hex Nut ($\frac{3}{4}$ -10)
12	46909	1	Warning Decal
13	43176	1	Upright Spacer
14	61144	1	Lower Bolster
15	10204	3	Hex Nut ($\frac{3}{8}$ -16)
16	10049	3	Hex Hd. Cap Screw ($\frac{3}{8}$ -16 x 1-in. Long)
17	51229	1	Upright, Right-Hand

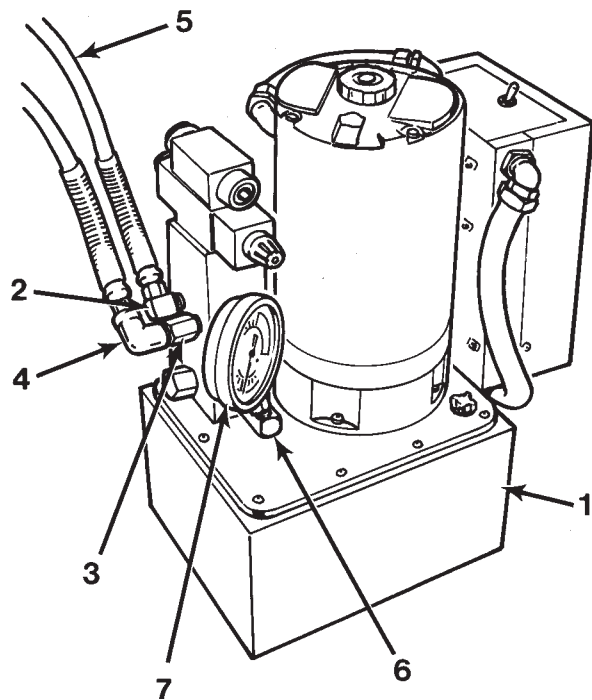

61217 and 4064 Electric Pump

Item No.	Part No.	No. Req'd	Description
1	61217	1	Electric Pump (Used on 1858)
	4064	1	Electric Pump (Used on 1858-1P)
2	10474	1	Elbow Fitting (90° x $\frac{3}{8}$ NPTF)
3	13828	1	Straight Fitting ($\frac{3}{8}$ NPTF)
4	10647	1	Elbow Fitting (90° x $\frac{3}{8}$ NPTF)
5	36888	2	Hyd. Hose, 10 ft.
6	10645	1	45° Street Elbow
7	10492	1	Gauge

Not Shown

50931	1	Pump Mounting Bracket
-------	---	-----------------------

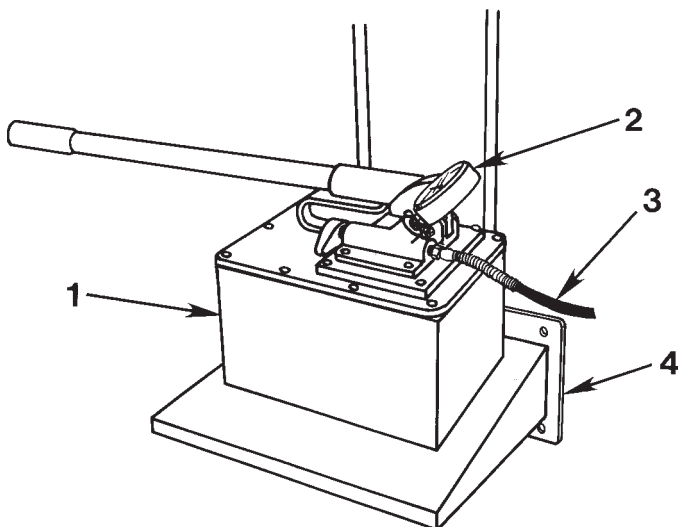

4008 Hand Pump

Item No.	Part No.	No. Req'd	Description
1	4008	1	Hand Pump (Used on 1857)
2	10492	1	Gauge
3	303840	1	Hyd. Hose, 10 ft.
4	50931	1	Pump Mounting Bracket

Cable Assembly

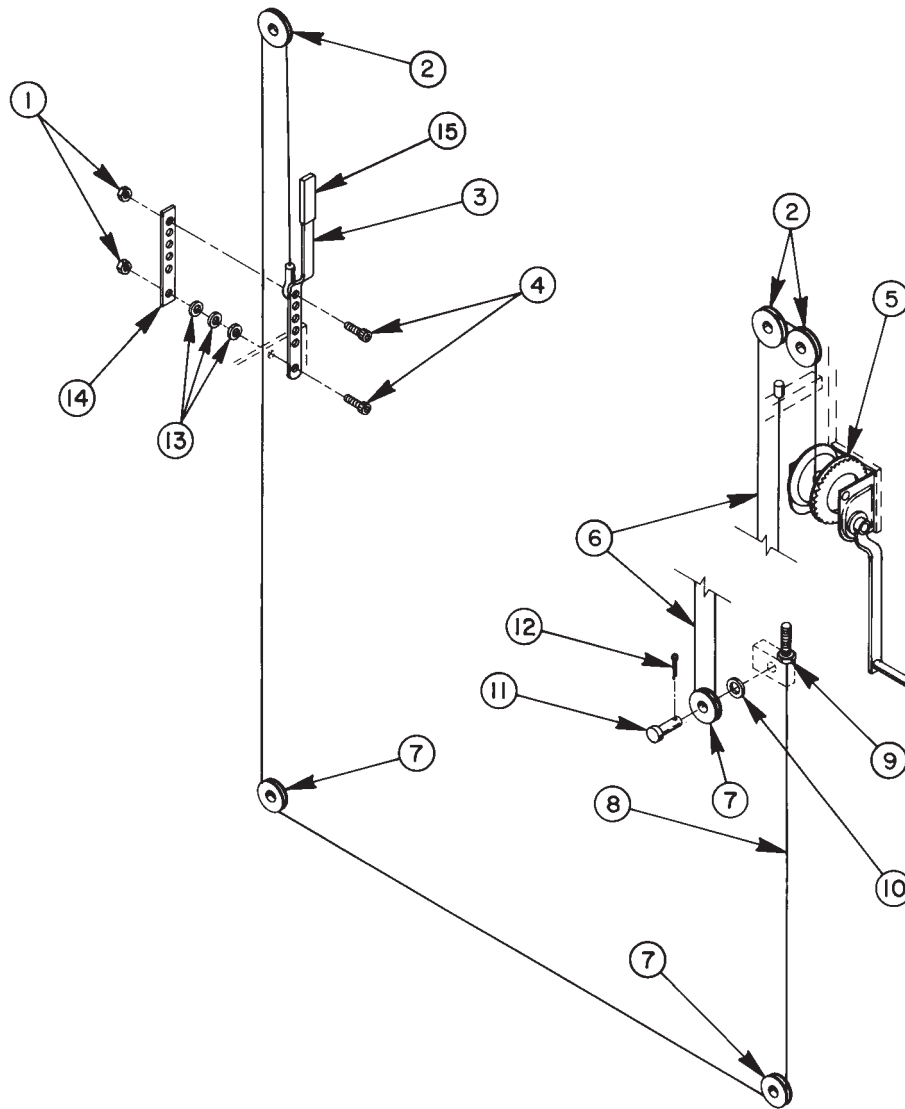

Item No.	Part No.	No. Req'd	Description	Item No.	Part No.	No. Req'd	Description
1	12809	2	Lock Nut (1/4-20)	8	38200	1	Press Cable
2	16659	3	Pulley (3-in. O.D.)	9	10204	1	Hex Nut (3/8-16)
3	38579	1	Handle	10	12330	1	Washer
4	10020	2	Cap Screw (1/4-20 x 1 1/4-in. long)	11	16654	3	Clevis Pin
5	18895-1	1	Winch	12	10472	3	Cotter Pin
6	207043	1	Winch Cable	13	12719	3	Washer
7	16653	3	Pulley (2 1/2-in. O.D.)	14	201929	1	Cable Strap
				15	17241	1	Handle Grip

Cylinder Mounting Assembly

Single-Acting Cylinder

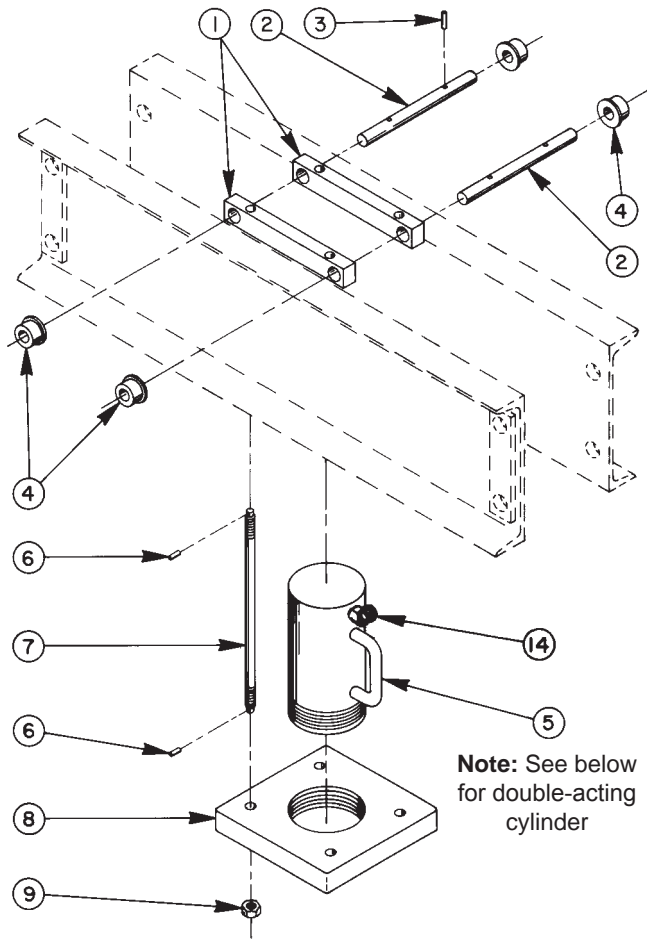

Note: See below for double-acting cylinder

Item No.	Part No.	No. Req'd	Description
1	44419	2	Bar
2	302551	2	Bar
3	10982	4	Slotted Spring Pin ($\frac{1}{4}$ -in. dia. x $1\frac{1}{2}$ -in. long)
4	206944	4	Roller
5	52434	1	Single-Acting Cylinder (Used on 1857; includes Item 14)
	51683	1	Double-Acting Cylinder (Used on 1858 and 1858-1P; includes Item 14)
6	10585	8	Roll Pin ($\frac{1}{4}$ -in. dia. x 1-in. long)
7	302549	4	Threaded Rod
8	52451	1	Cylinder Mtg. Plate (Used on 1857)
	51786	1	Cylinder Mtg. Plate (Used on 1858 and 1858-1P)
9	10216	4	Hex Nut ($\frac{3}{4}$ -10 UNC)
10	10204	2	Hex Nut ($\frac{3}{8}$ -16)
11	50931	1	Pump Mounting Bracket
12	10052	2	Hex Hd. Cap Screw ($\frac{3}{8}$ -16 x $1\frac{1}{4}$ -in. long)
13	10798	4	Hex Hd. Cap Screw ($\frac{1}{2}$ -20 x $\frac{3}{4}$ -in. long)
14	10648	1	45° Elbow Fitting (included with 52434 Single-Acting Cylinder)
		2	45° Elbow Fitting (included with 51683 Double-Acting Cylinder)

Double-Acting Cylinder

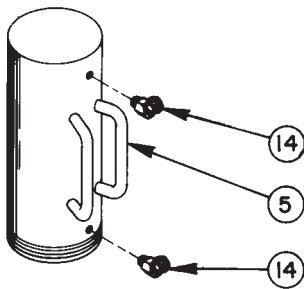

Pump Mounting Bracket

