



Assembly & Operating Instructions for:

014-00094	1852
014-00095	211750
1850	61309
1851	

Shop Press Frame

Maximum Capacity: 55 Tons

These instructions are intended for various shop presses. Some models are shipped assembled and require a minor amount of assembly; others are shipped unassembled and require complete assembly. The complete assembly procedure is provided in the following instructions for your reference. Verify the contents of the shipping carton against the parts list provided to ensure all parts are present before beginning assembly.

Safety Precautions



WARNING: To prevent personal injury,



- Read and carefully follow the operating instructions and safety precautions for the press and hydraulic cylinder. Most problems are caused by incorrect assembly or operation.
- The owner of the press must ensure the press is installed and operated according to Federal (OSHA), state, and local safety standards.
- A press can exert an extremely high force at a moderate hydraulic pump pressure. If you have any questions about how much force is exerted at a given pressure, contact Technical Services.
- This press is designed for shop maintenance applications. For use in other applications, contact Technical Services.

Operation

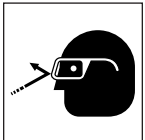

- Wear eye protection that meets ANSI Z87.1 and OSHA standards. Keep hands away from the work area. Locate the press in an isolated area or shield it to minimize danger to others. Hydraulic pressure can cause materials to break, possibly resulting in personal injury.



- It is impossible for the manufacturer to provide practical, all-purpose shielding because this is a general purpose press used in many different applications. The owner of the press must supply shielding (such as the 1230PB or 2036PB available through OTC) that is practical and specific for a particular application.



- A work piece must be well supported and aligned to prevent slippage and breakage.
- To prevent accidental slippage, do not place work piece on the press bed or apply hydraulic force until all bolster pins are in place and all tension has been removed from the bolster lift cables.
- Do not stress adapters beyond their capacities. Pushing or pulling adapters used with this press must have a maximum tonnage rating equal to, or greater than, the maximum tonnage rating of the press. Otherwise, breakage may occur.
- The user must ensure all safety-related decals are installed, maintained, and replaced when necessary.
- Keep hands, feet, legs, etc. out from under the bolster. Accidental slippage can result in personal injury.

Assembly & Operating Instructions



WARNING (cont'd)



- To prevent accidental cable breakage, never raise or lower the bolster while there is a load on it.
- When lowering the bolster, remove the work piece. Place one support pin all the way through each front and the back upright in the highest hole under the bolster that will not interfere with the new bolster position. Remove your hands from the support pins after the pins are in place.
- When raising the bolster, remove the work piece. Leave the support pins in place until the bolster is raised to its new position. Remove your hands from the support pins after the pins are in place.
- Inspect the entire length of the lifting cables at least every three months, and replace cables that appear frayed, worn, or crushed. The cables must run on the pulleys easily and the pulleys must be free to turn. Correct cable maintenance helps prevent cable breakage.

Assembly

Note: Refer to Figure 1 on next page for location of item numbers referenced below.

IMPORTANT: During the assembly of the press, hand tighten all nuts and bolts, unless directed otherwise. Once assembly is complete, use a wrench to tighten all hardware.

1. Place the lower bolster (Item 9) on two wood blocks (4x4s approximately 24 in. long). Place blocks perpendicular to the bolster. **IMPORTANT: Make sure the cable attachment holes in the bolster plates are facing up.**
2. Attach a foot angle (12) to each press upright (3) using cap screws (17) and hex nuts (6).
3. Insert the threaded rod (13) into the spacer (14). Attach spacer assembly between the press uprights (3) and foot angles (12) using two washers (16) and nuts (6).
4. Attach back upper bolster (1) to top of uprights using six cap screws (5) and jam nuts (4). *NOTE: The mounting hole for the cylinder plate (8) must be facing down.*
5. **For the right side:**
 - a. Insert pulley axle (22) through front side of upright (3).
 - b. Slide pulley (25) onto pulley axle inside upright frame. Continue inserting axle through back side of upright until it bottoms out against back bolster.
6. **For the left side:**
 - a. Insert pulley axle (22) through front side of upright. Slide two pulleys (24) and four spacers (21) on pulley axle inside upright frame. Continue inserting axle through back side of upright until it bottoms out against back bolster.
6. Attach front upper bolster (1) to uprights using six cap screws (5) and jam nuts (4). *NOTE: The mounting hole for the cylinder plate (8) must be facing down.* Once attached, the front upper bolster holds the axle pulleys in place.
7. Attach winch assembly (18) to left upright using two bolts (19). Wrench tighten bolts at this time.
8. Locate the end of the cable without a clevis and feed that end of the cable down the left side of the press. See Figure 1, Detail A. Attach that end of the cable to the cable clamp on the side of the winch. **IMPORTANT: After feeding the cable through the cable clamp, wrench tighten the clamp to secure the cable.**
9. Route cable assembly (27) over *front* pulley on left upright. Loop *longest cable* around pulley on right side of press and feed it back over to the left upright, looping the cable over the *rear* pulley. Continue feeding the cable down to the bolster weldment on left lower bolster; attach the cable to the bolster weldment with a cap screw (20) and self-locking nut (23).
10. Loop short cable (with clevis) around pulley on right side of press down to the bolster weldment hole on the right lower bolster; attach the cable to the bolster weldment with a cap screw (20) and self-locking nut (23).
11. Using winch, carefully raise lower bolster. Install bolster pins (11) below raised bolster and lower bolster onto pins before removing wood blocks used earlier in Step 1.

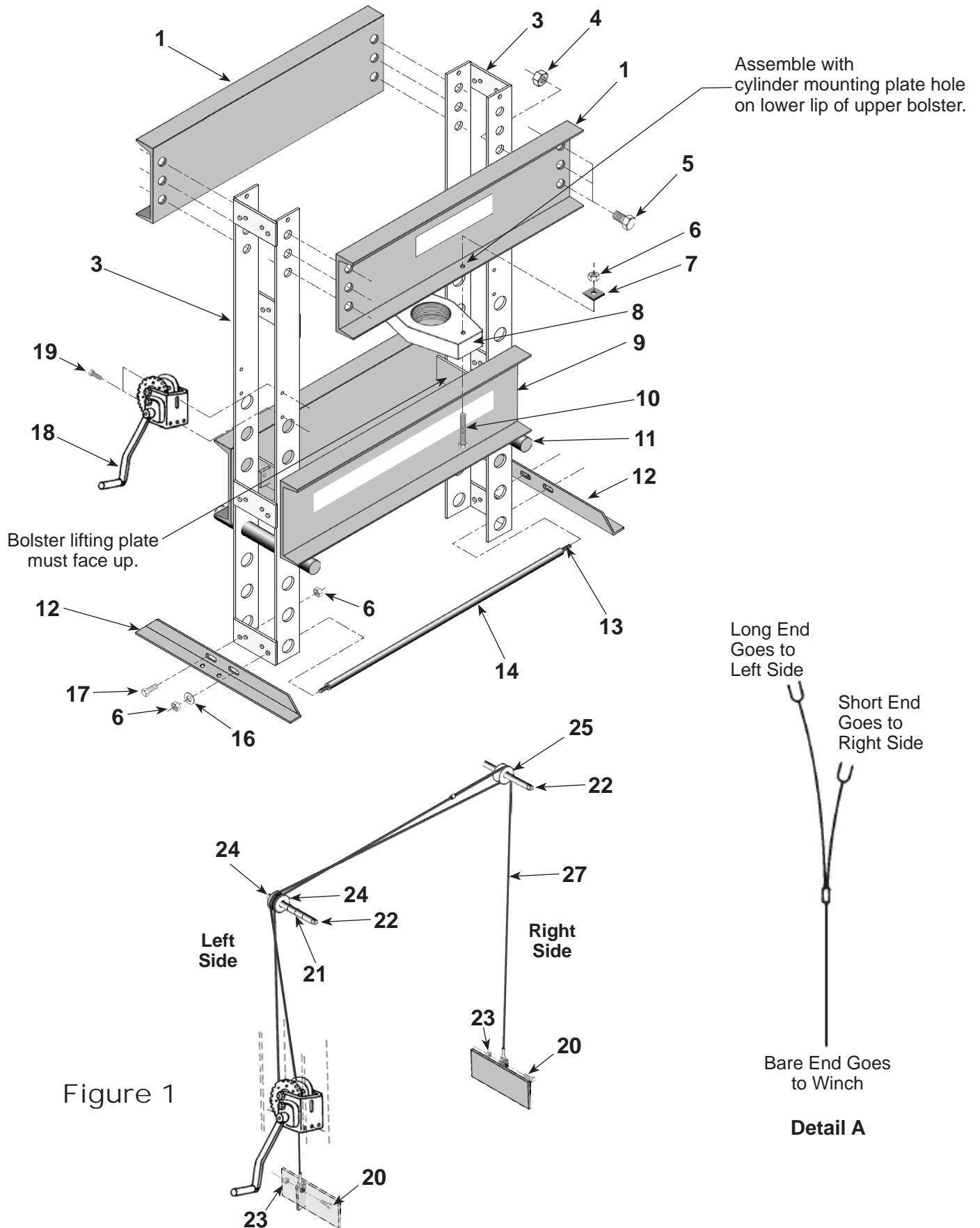

Assembly & Operating Instructions

Hydraulic Connections

Note: Refer to Figure 1 on previous page for location of item numbers referenced below. Also, step 1 only applies to press frames where the hydraulic pump is mounted to the side of the frame — some pumps rest directly on the floor and do not require a pump mounting bracket.

1. If your pump mounts to the side of the press, attach the pump mounting bracket to the right-hand upright using two 3/8 in. bolts and nuts. Attach the pump to the mounting bracket using the mounting hardware supplied with the pump.

CAUTION: Use a high-grade, non-hardening pipe sealant to seal all hydraulic connections. Teflon tape can be used if only ONE layer of tape is applied. Ensure the first thread is exposed without tape. Carefully apply the tape to prevent the tape from becoming pinched or broken off inside the hydraulic system. Loose pieces of tape can travel through a hydraulic system, which could potentially obstruct the flow of oil and damage the system.

2. Assemble the hydraulic hose and gauge to the pump using the hose, gauge, adapters, and couplers supplied.
3. Thread the hydraulic cylinder into cylinder mounting plate. **IMPORTANT:** The threads of the cylinder must be flush with the bottom of the mounting plate for full thread engagement.
4. Place a two-inch-thick support, such as a wood block, across the top of the lower bolster. Place the cylinder assembly on the support. This additional height will be needed for the cylinder assembly to reach the upper bolster. **IMPORTANT:** The pipe plug on the cylinder must face the pump side of the press frame.
5. Operate the winch mechanism to raise the cylinder assembly to the upper bolster.
6. Attach the cylinder mounting plate to the upper bolsters with cap screws (10), hex nuts (6), and beveled washers (7). *NOTE: Place the beveled washers on top of the bottom lip of the upper bolster. The larger dimension of the beveled washer is positioned to the outside of the bolster to provide a level surface when tightening the hex nuts.* Once the beveled washers are in their correct position, wrench tighten the hex nuts.
7. After the cylinder assembly has been secured to the upper bolster, lower the bolster assembly onto the bolster pins.
8. Bleed the hydraulic system by slowly operating the pump handle until an air-free stream of hydraulic oil flows from the hose.
9. Remove the pipe plug on the cylinder and attach the hydraulic hose.
10. Straighten the press and wrench tighten all hex nuts and cap screws.

CAUTION:

- **To prevent damage to the finished surface of the cylinder piston rod, when the press is not in use, retract the cylinder.**
- **Use only a high-grade hydraulic oil when refilling the pump reservoir. Never use brake fluid or other substitute.**



Parts List

for:	014-00094	1850
	014-00095	1851
		1852

Shop Press
Max. Capacity: 55 Tons

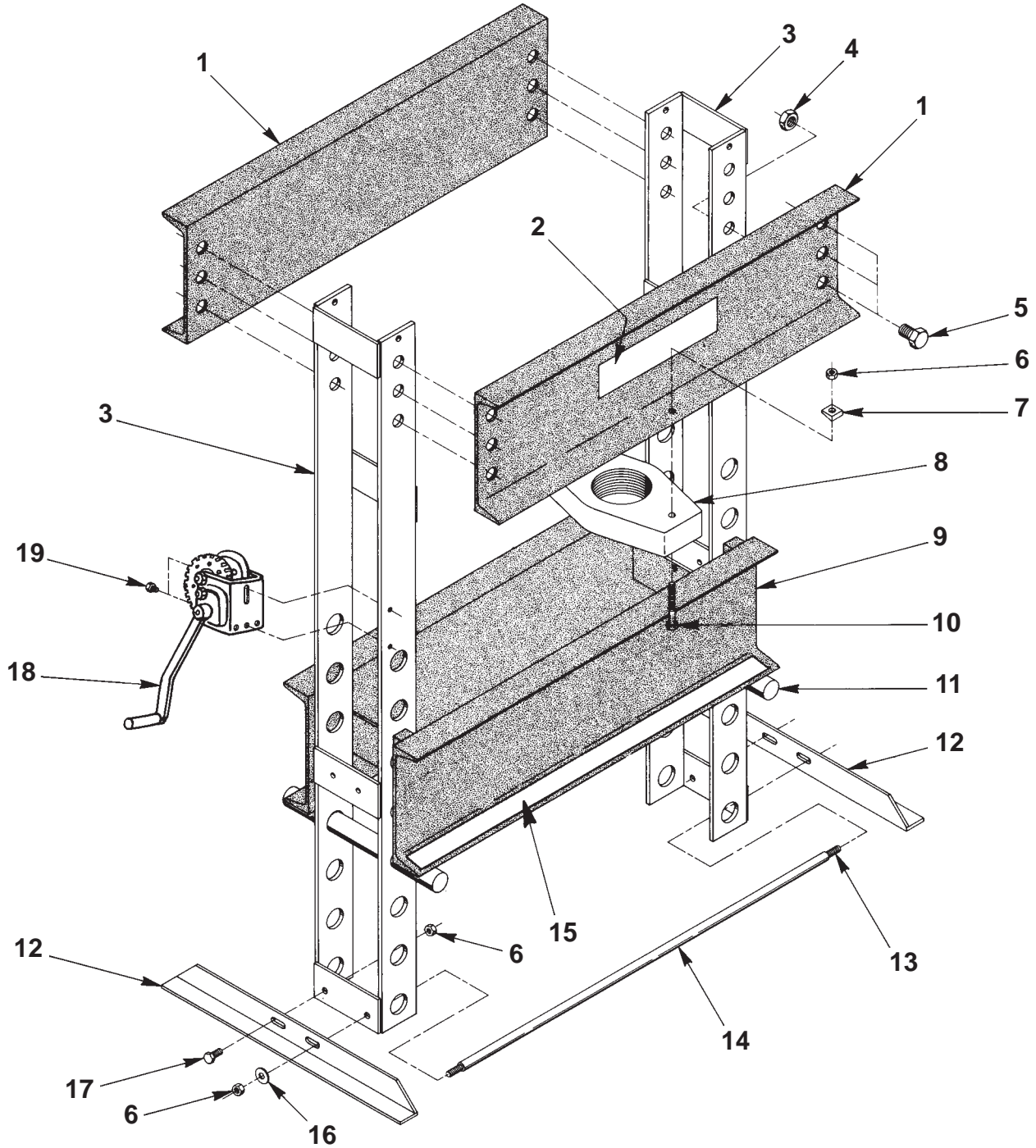

Parts List

Item No.	Part No.	No. Req'd	Description
1	41751	2	Upper Bolster
2	304984	1	Trade Name Decal (Used on 1850, 1851, & 1852)
	12768	1	Trade Name Decal (Used on 014-00094 & 014-00095)
3	52461	1	Upright
4	10401	12	Jam Nut
5	15081	12	Cap Screw (1-8 UNC x 1½-in. long)
6	10208	6	Nut (½-13 UNC)
7	10610	2	Bevel Washer (Used on ½-in. bolt)
8	50954	1	Ram Mounting Plate
9	61049	1	Lower Bolster
10	10093	2	Cap Screw (½-13 UNC x 4-in. long)
11	303501	2	Bolster Pin
12	304485	2	Foot Angle
13	211991	1	Threaded Rod
14	211990	1	Spacer
15	46909	1	Warning Decal
16	10586	2	Washer (Used on ½-in. bolt)
17	10079	2	Cap Screw (½-13 UNC x 1-in. long)
18	18895-1	1	Winch
19	12368	2	Cap Screw (¾-16 UNC x ½-in. long)

NOT SHOWN

52457	1	Hydraulic Cylinder
205329	1	Part Number Decal (Used on 014-00094)
205330	1	Part Number Decal (Used on 014-00095)

4016 & 60614 HAND PUMP

(Used on 1850 & 014-00095)

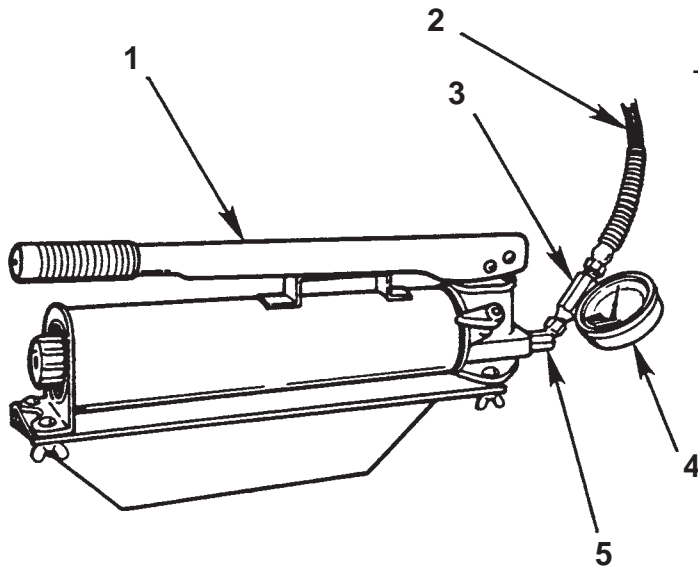

Item No.	Part No.	No. Req'd	Description
1	4016	1	Hand Pump (Used on 1850)
	61821	1	Hand Pump (Used on 014-00095)
2	36886	1	Hydraulic Hose (6 ft.)
3	24815	1	Tee Adapter
4	10492	1	Gauge (Used on 1850)
	16457	1	Gauge (Used on 014-00095)
5	10648	1	45° Elbow

4020 & 203398 AIR PUMP

(Used on 1851 & 014-00094)

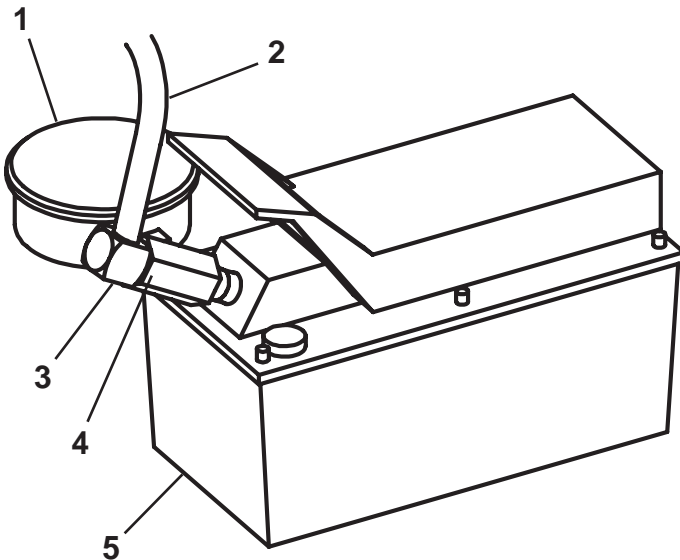

Item No.	Part No.	No. Req'd	Description
1	10492	1	Gauge (Used on 1851)
	16457	1	Gauge (Used on 014-00094)
2	36888	1	Hydraulic Hose (6 ft)
3	10474	1	90° Elbow
4	24815	1	Tee Adapter
5	4020	1	Air Pump (Used on 1851)
	203398	1	Air Pump (Used on 014-00094)

Parts List

4044 ELECTRIC PUMP

(Used on 1852)

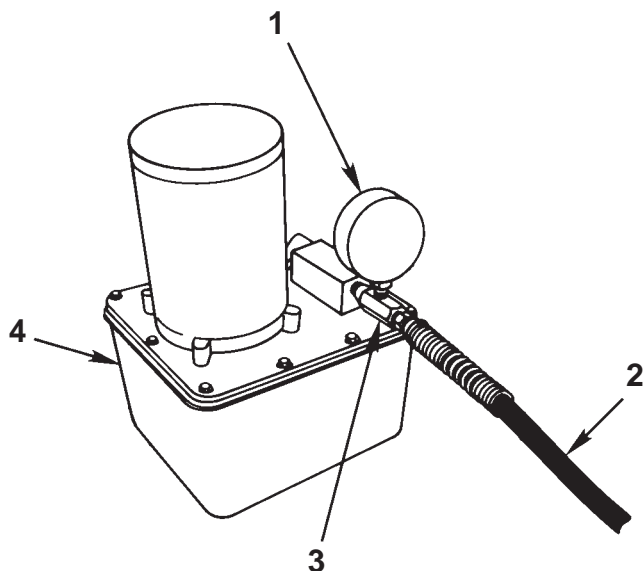

Item No.	Part No.	No. Req'd	Description
1	9069	1	Gauge
2	9767	1	Hydraulic Hose (6 ft.)
3	9670	1	Tee Adapter
4	4044	1	Electric Pump

PUMP MOUNTING BRACKETS

(Used on 1850, 1852, & 014-00095)

ELECTRIC PUMP

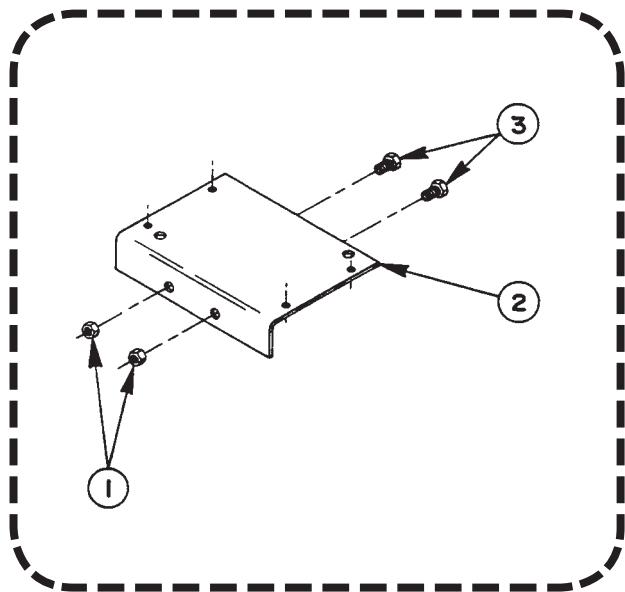

HAND PUMP

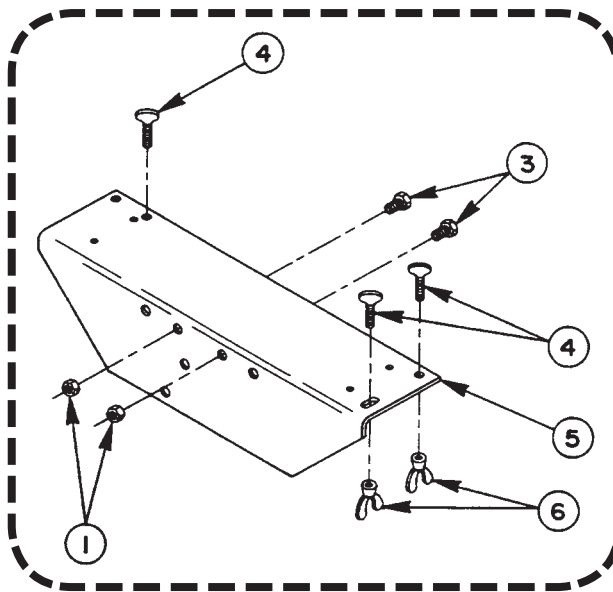

Item No.	Part No.	No. Req'd.	Description
1	10204	2	Nut ($\frac{3}{8}$ -16 UNC)
2	40864	1	Electric Pump Mounting Bracket
3	10046	2	Cap Screw ($\frac{3}{8}$ -16 UNC x $\frac{3}{4}$ -in. long)
4	12680	3	Thumb Screw (Used on hand pump)
5	42733	1	Hand Pump Mounting Bracket (Used on 1850)
6	10590	3	Wing Nut

NOTE: The air pump version of this shop press does not have a mounting bracket.

CABLE ASSEMBLY

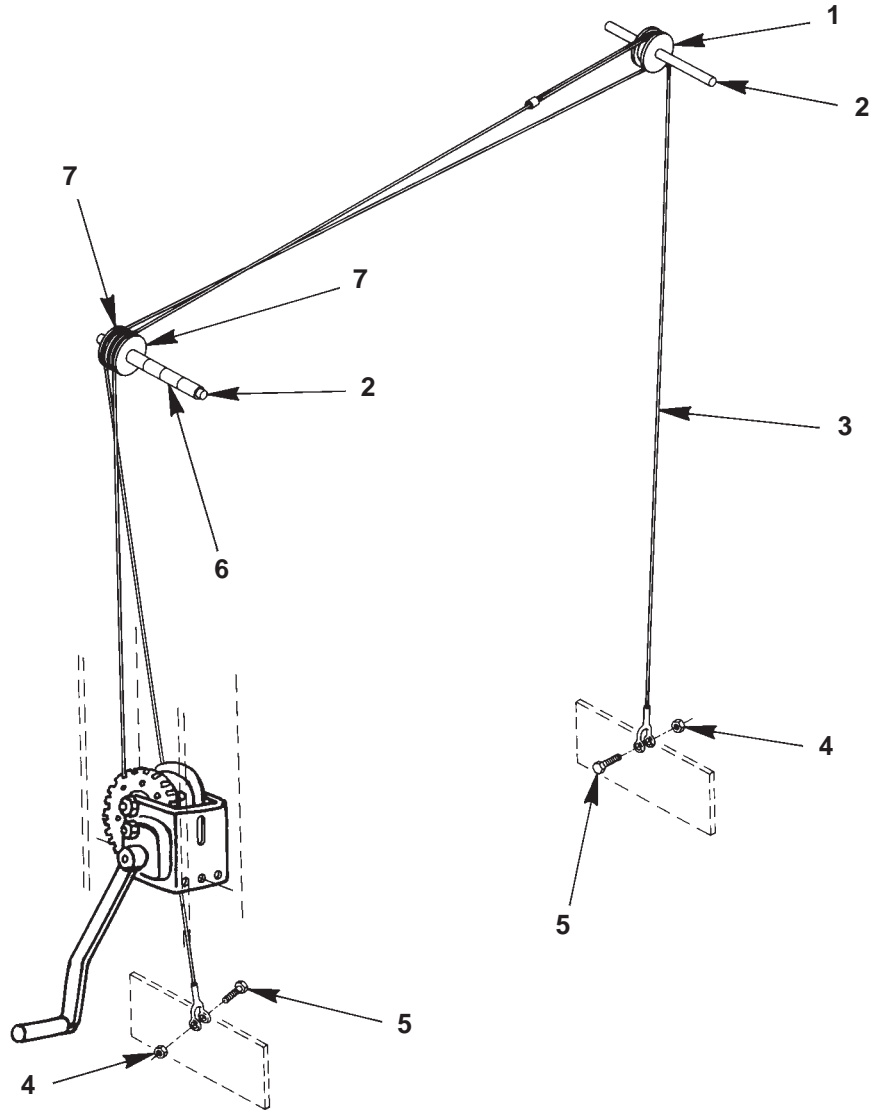

Item No.	Part No.	No. Req'd	Description
1	200785	1	Pulley
2	200056	2	Pulley Axle
3	45999	1	Cable
4	12809	2	Self-locking Nut
5	10019	2	Cap Screw (1/4-20 x 1 1/4-in. long)
6	206680	4	Spacer
7	29695	2	Pulley