

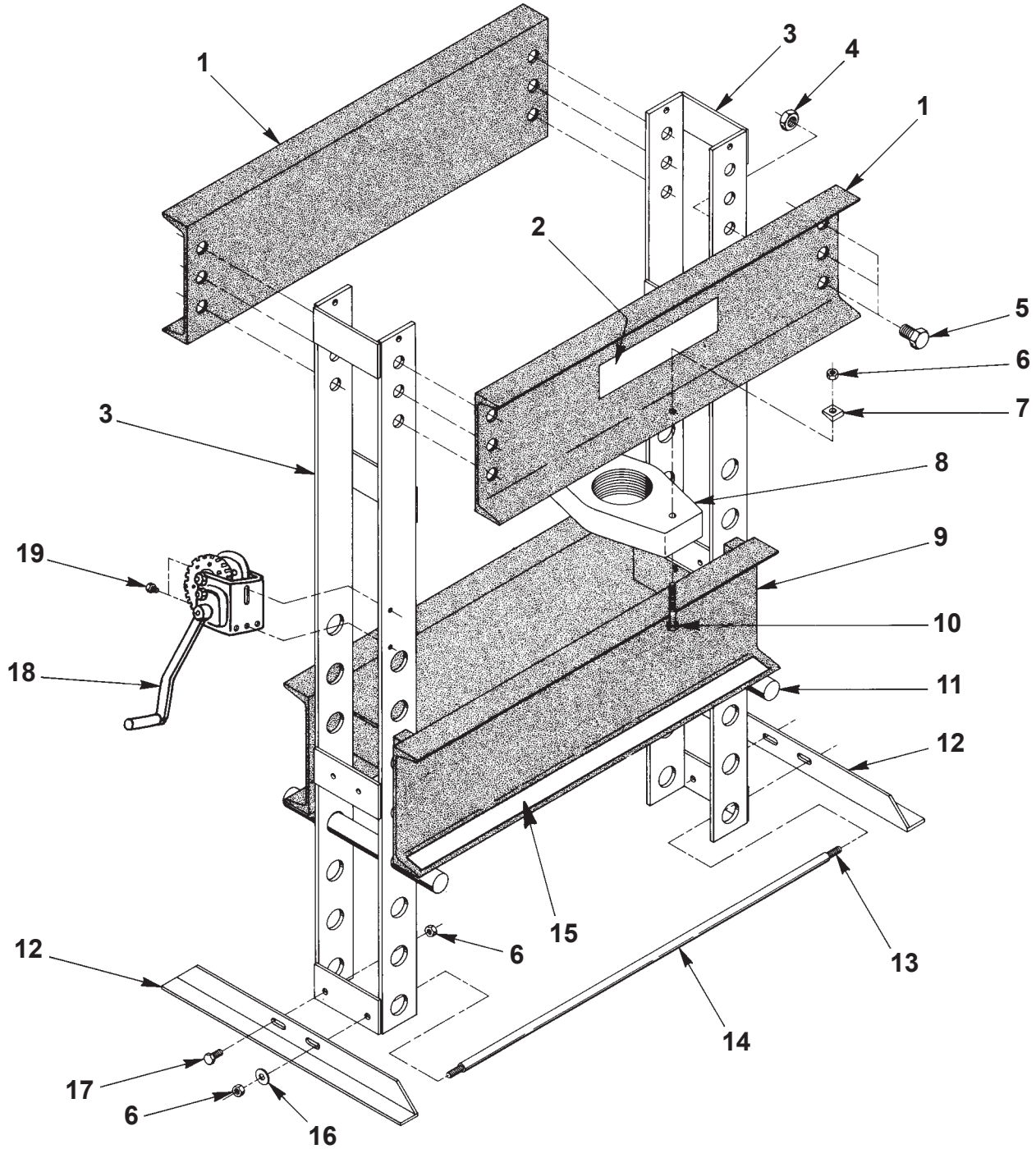

Parts List
for:

014-00094	1850
014-00095	1851
	1852

Shop Press
Max. Capacity: 55 Tons



Item No.	Part No.	No. Req'd	Description
1	41751	2	Upper Bolster
2	304984	1	Trade Name Decal (Used on 1850, 1851, & 1852)
	12768	1	Trade Name Decal (Used on 014-00094 & 014-00095)
3	52461	1	Upright
4	10401	12	Jam Nut
5	15081	12	Cap Screw (1-8 UNC x 1½-in. long)
6	10208	6	Nut (½-13 UNC)
7	10610	2	Bevel Washer (Used on ½-in. bolt)
8	50954	1	Ram Mounting Plate
9	61049	1	Lower Bolster
10	10093	2	Cap Screw (½-13 UNC x 4-in. long)
11	303501	2	Bolster Pin
12	304485	2	Foot Angle
13	211991	1	Threaded Rod
14	211990	1	Spacer
15	46909	1	Warning Decal
16	10586	2	Washer (Used on ½-in. bolt)
17	10079	2	Cap Screw (½-13 UNC x 1-in. long)
18	18895-1	1	Winch
19	12368	2	Cap Screw (¾-16 UNC x ½-in. long)

NOT SHOWN

52457	1	Hydraulic Cylinder
205329	1	Part Number Decal (Used on 014-00094)
205330	1	Part Number Decal (Used on 014-00095)

Refer to any operating instructions included with the product for detailed information about operation, testing, disassembly, reassembly, and preventive maintenance.

Items found in this parts list have been carefully tested and selected. **Therefore: Use only genuine replacement parts!**

Additional questions can be directed to our Technical Services Department.

4016 & 60614 HAND PUMP

(Used on 1850 & 014-00095)

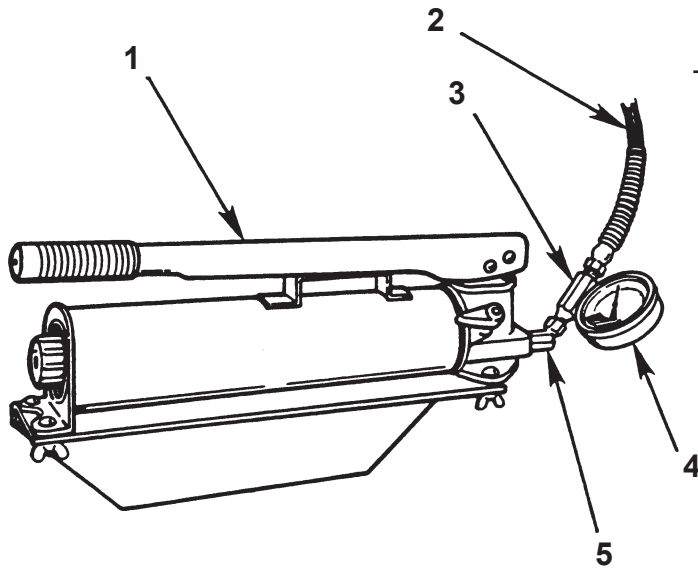

Item No.	Part No.	No. Req'd	Description
1	4016	1	Hand Pump (Used on 1850)
	61821	1	Hand Pump (Used on 014-00095)
2	36886	1	Hydraulic Hose (6 ft.)
3	24815	1	Tee Adapter
4	10492	1	Gauge (Used on 1850)
	16457	1	Gauge (Used on 014-00095)
5	10648	1	45° Elbow

4020 & 203398 AIR PUMP

(Used on 1851 & 014-00094)

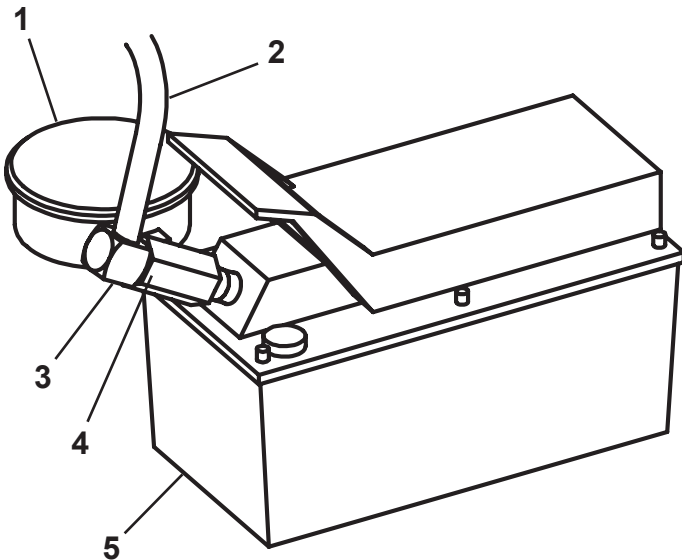

Item No.	Part No.	No. Req'd	Description
1	10492	1	Gauge (Used on 1851)
	16457	1	Gauge (Used on 014-00094)
2	36888	1	Hydraulic Hose (6 ft)
3	10474	1	90° Elbow
4	24815	1	Tee Adapter
5	4020	1	Air Pump (Used on 1851)
	203398	1	Air Pump (Used on 014-00094)

4044 ELECTRIC PUMP

(Used on 1852)

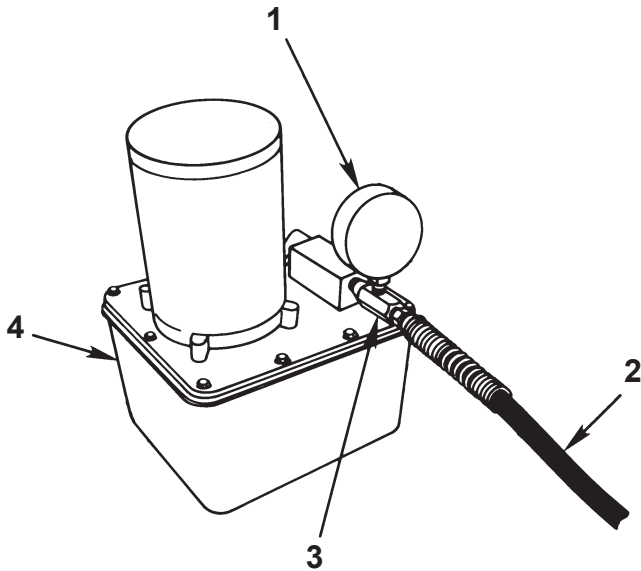

Item No.	Part No.	No. Req'd	Description
1	9069	1	Gauge
2	9767	1	Hydraulic Hose (6 ft.)
3	9670	1	Tee Adapter
4	4044	1	Electric Pump

PUMP MOUNTING BRACKETS

(Used on 1850, 1852, & 014-00095)

ELECTRIC PUMP

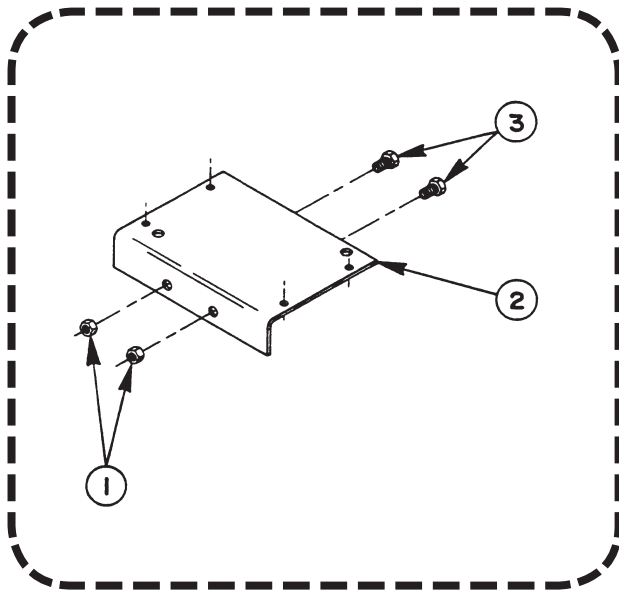

HAND PUMP

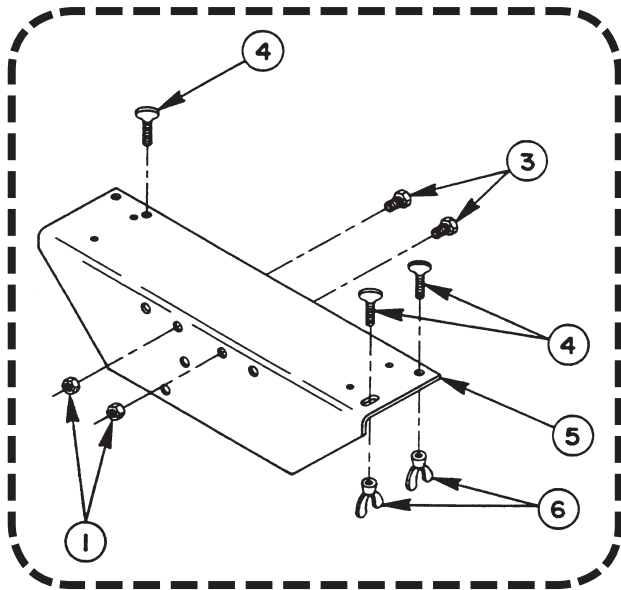

Item No.	Part No.	No. Req'd.	Description
1	10204	2	Nut ($\frac{3}{8}$ -16 UNC)
2	40864	1	Electric Pump Mounting Bracket
3	10046	2	Cap Screw ($\frac{3}{8}$ -16 UNC x $\frac{3}{4}$ -in. long)
4	12680	3	Thumb Screw (Used on hand pump)
5	42733	1	Hand Pump Mounting Bracket (Used on 1850)
6	10590	3	Wing Nut

NOTE: The air pump version of this shop press does not have a mounting bracket.

CABLE ASSEMBLY

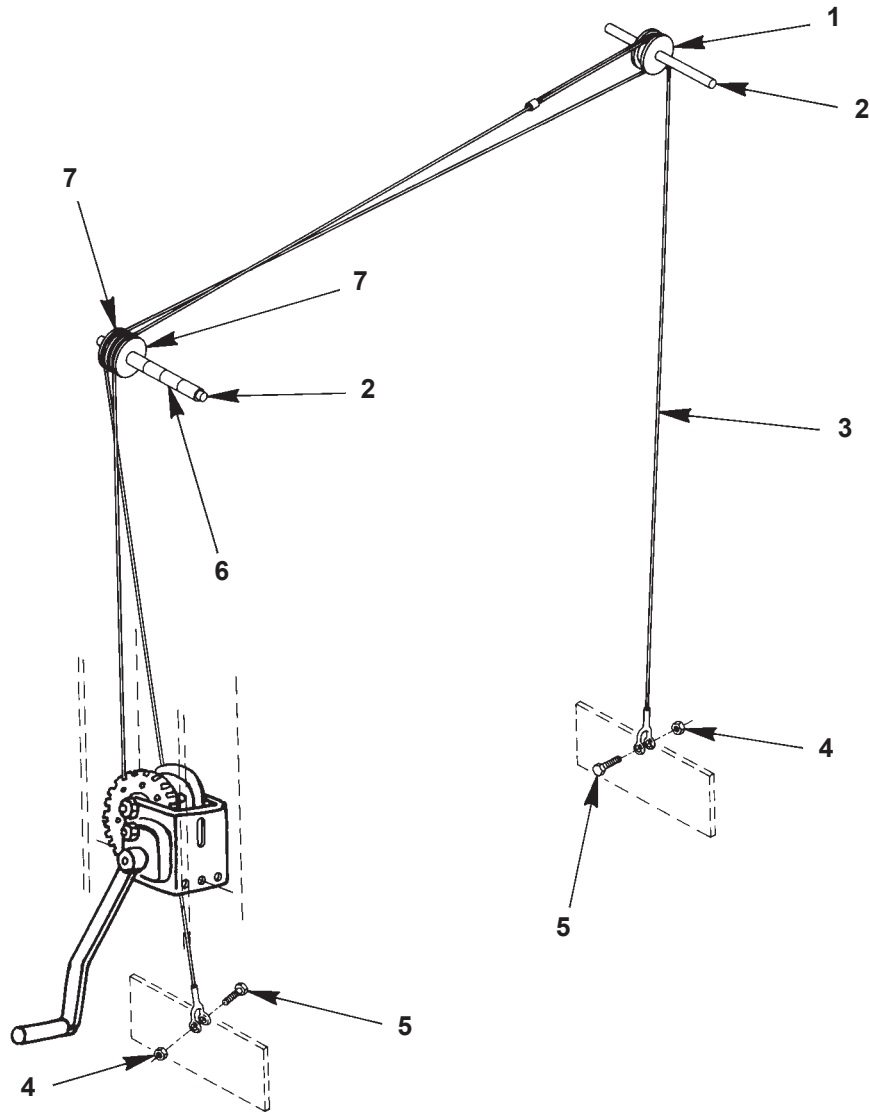

Item No.	Part No.	No. Req'd	Description
1	200785	1	Pulley
2	200056	2	Pulley Axle
3	45999	1	Cable
4	12809	2	Self-locking Nut
5	10019	2	Cap Screw (1/4-20 x 1 1/4-in. long)
6	206680	4	Spacer
7	29695	2	Pulley