



Parts List for:

1845
1846A
1847
1872
1872-220V

Hydraulic Shop Press

Maximum Capacity: 55 Tons

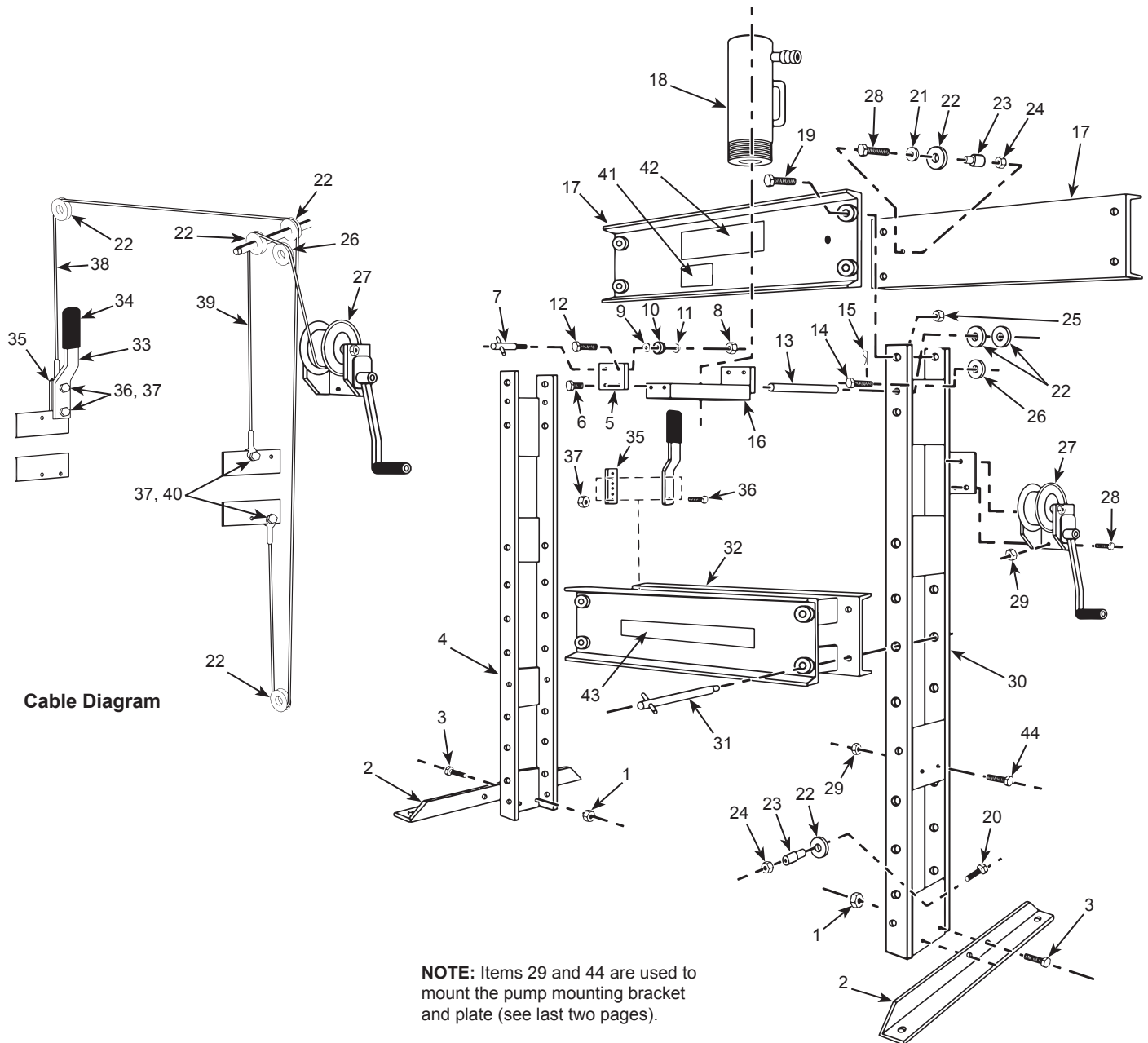

Item No.	Part No.	No. Req'd	Description	Item No.	Part No.	No. Req'd	Description
-	576780	1	Press Frame (Complete frame only.)	22	16659	4	Pulley (3 in. dia.)
1	10216	4	Hex Nut (3/4-10 UNC)	23	202468	2	Spacer
2	25849	2	Press Foot	24	15013	2	Locknut (1/2-13 UNC)
3	10119	4	Hex Hd. Cap Screw (3/4-10 UNC x 1-3/4 in. lg.)	25	10221	8	Hex Nut (1-8 UNC)
4	42471	1	Left-hand Upright	26	16653	1	Pulley (2-1/2 in. dia.)
5	202496	2	Plate	27	18895-1	1	Winch
6	10079	4	Hex Hd. Cap Screw (1/2-13 UNC x 1 in. lg.)	28	10049	3	Hex Hd. Cap Screw (3/8-16 UNC x 1 in. lg.)
7	25825	2	Adjusting Screw	29	10204	5	Hex Nut (3/8-16 UNC; For 1845 & 1846A. NOTE: Two for mounting plate; Three for winch.)
8	10208	4	Hex Nut (1/2-13 UNC)		10204	3	Hex Nut (3/8-16 UNC; For 1847)
9	12004	12	SAE Washer (1/2 in. bolt) (Note: Use two washers per roller. Add/subtract washers to adjust roller engagement with upper bolster.)		10204	7	Hex Nut (3/8-16 UNC; For 1872 & 1872-220V)
10	202498	4	Roller	30	42470	1	Right-hand Upright
11	202497	4	Bushing	31	25846	4	Pin Assembly
12	12896	4	Hex Hd. Cap Screw (1/2-13 UNC x 2-1/4 in. lg.)	32	51536	1	Lower Bolster
13	202490	1	Pulley Axle	33	38579	1	Handle
14	16654	1	Clevis Pin (3/4 in. dia. x 2 in. lg.)	34	17241	1	Handle Grip
15	10472	1	Cotter Pin	35	201929	1	Cable Adjuster Strap
16	50954	1	Ram Mounting Plate	36	10017	2	Hex Hd. Cap Screw (1/4-20 UNC x 1 in. lg.)
17	33328	2	Upper Bolster	37	12809	4	Locknut (1/4-20 UNC)
18	52380A	1	Single-acting Cylinder (For 1847 & 1845)	38	202483	1	Press Cable
	65458	1	Single-acting Cylinder (For 1846A)	39	204728	1	Winch Cable
	51682	1	Double-acting Cylinder (For 1872 & 1872-220V)	40	10019	2	Hex Hd. Cap Screw (1/4-20 UNC x 1-1/4 in. lg.)
19	12697	8	Hex Hd. Cap Screw (1-8 x 3 in. lg.)	41	206043	1	Instruction Decal
20	10089	2	Hex Hd. Cap Screw (1/2-13 x 2-1/2 in. lg.)	42	304984	1	Trade Name Decal
21	12004	1	SAE Washer (1/2 in. bolt)	43	46896	1	Warning Decal
				44	10052	2	Hex Hd. Cap Screw (3/8-16 UNC x 1-1/4 in. lg.; For 1845 & 1846A)
					10052	4	Hex Hd. Cap Screw (3/8-16 UNC x 1-1/4 in. lg.; For 1872 & 1872-220V)

Electric Pump

(Used on 1845, 1872, & 1872-220V)

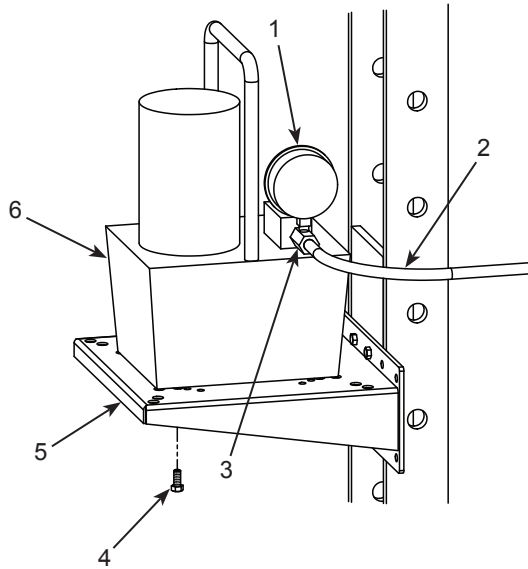

1845

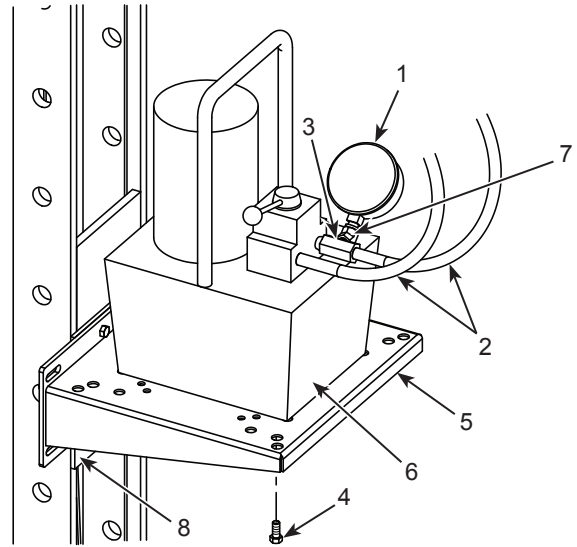

1872 & 1872-220V

Item No.	Part No.	No. Req'd	Description
1	10492	1	Gauge
2	303563	1	Hydraulic Hose (For 1845)
	36887	2	Hydraulic Hose (For 1872 & 1872-220V)
3	24815	1	Tee Adapter
4	10048	4	Hex Hd. Cap Screw (3/8-16 UNC x 7/8 in. lg.)
5	50931	1	Pump Mounting Bracket
6	4044	1	Electric Pump (For 1845)
	4046	1	Electric Pump (For 1872)
	4046-50-220	1	Electric Pump (For 1872-220V)
7	10645	1	45° Elbow
8	44733	1	Plate

Hand Pump
(Used on 1846A)

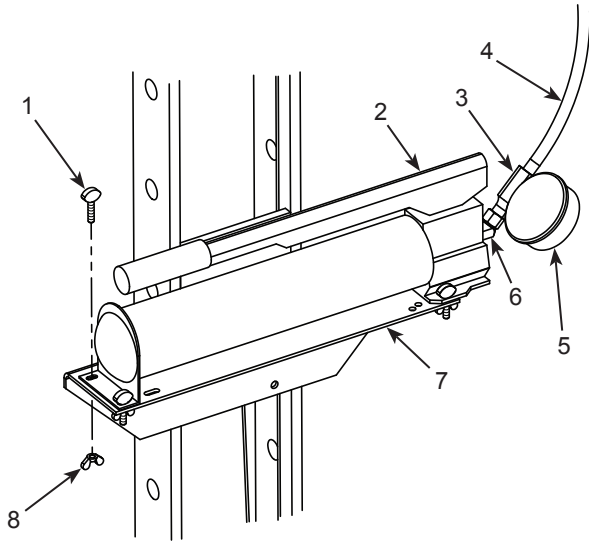

Item No.	Part No.	No. Req'd	Description
1	12680	3	Thumb Screw
2	4016	1	Hand Pump
3	24815	1	Tee Adapter
4	303563	1	Hydraulic Hose
5	10492	1	Gauge
6	10648	1	45° Elbow
7	42733	1	Pump Mounting Bracket
8	10590	3	Wing Nut

Air Pump
(Used on 1847)

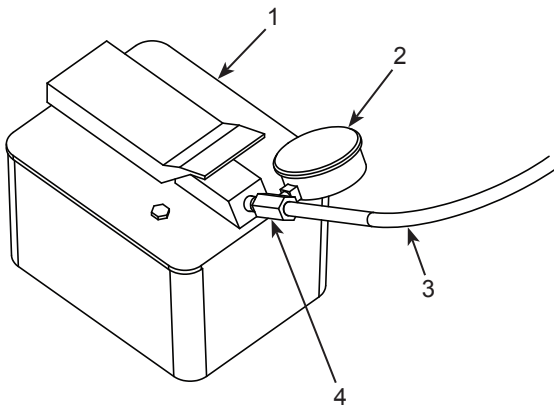

Item No.	Part No.	No. Req'd	Description
1	4022	1	Air Pump
2	10492	1	Gauge
3	36888	1	Hydraulic Hose
4	24815	1	Tee Adapter