

Please read and save these instructions. Read through this owner's manual carefully before using product. Protect yourself and others by observing all safety information, warnings, and cautions. Failure to comply with instructions could result in personal injury and/or damage to product or property. Please retain instructions for future reference.

OEM[®] BODY REPAIR KIT



GENERAL SAFETY PRECAUTIONS

WORK AREA

1. Keep the work area clean and well lit. Cluttered and dark areas invite accidents.
2. Keep children and bystanders away while working. Distractions can cause you to lose control and bystanders should be kept at a safe distance from the working area especially when work is in progress.

PERSONAL SAFETY

1. Stay alert, watch what you are doing and use common sense when using this equipment. Do not operate this equipment when you are tired, ill or under the influence of alcohol, drugs or medication.
2. Do not over-reach. Keep your proper footing and balance at all times. This enables better control of the equipment in unexpected situations.
3. Concentrate on the job in hand, no matter how trivial it may seem. Be aware that accidents are caused by carelessness due to familiarity.
4. Dress properly. Do not wear loose clothing or jewelry which may get caught in moving parts. Wear protective hair covering to contain long hair. For best footing, wear rubber soled footwear. Keep floor clear of oil, scrap wood, etc.

5. Before working on a vehicle with this repair kit, ensure the vehicle is well supported and completely stable.
6. Remember that during body repair, there is always the possibility of a fixture slipping or a body part failing, which could cause the vehicle to jolt suddenly. If the vehicle is not adequately supported, it could fall with possibly serious consequences.
7. Never use an additional extension handle to operate the pump.
8. Never modify this equipment in any way.
9. Check the equipment for damage before use. Any damaged part should be discarded and replaced. Check for alignment of parts, breakage of parts, and any other condition that may affect the operation. Any damage should be properly repaired or the part replaced. If in doubt, DO NOT use. Consult your local OEM technical support.
10. Store out of the reach of children and do not allow persons unfamiliar with these instructions to use this product.

ALWAYS WEAR SAFETY GOGGLES.

OEM[®] BODY REPAIR KIT

INTRODUCTION

Thank you for purchasing this OEM Body Repair Kit. This manual covers the compact 4 Ton Kit (24820) and the larger 10 Ton kit (24821), the 24821 featuring a faster (double-action) hydraulic pump causing the ram to move with both the up and down strikes of the arm. Before attempting to use the product, please read this manual thoroughly and follow the instructions carefully. In doing so you will ensure the safety of yourself and others around you, and you can look forward to your purchase giving you long life and satisfactory service.

TABLE OF CONTENTS

Introduction 2
Guarantee 2
General Safety Precautions ... 1
Specifications 2
Unpacking 3
Overview 4
Assembly 4
Operation 5
Maintenance 6
Fault Finding 6
Component Parts 7-8

Specifications

Description	4 Ton 24820	10 Ton 24821
Weight (complete in case)	17.6 kg	30 kg
Moulded case dims (L x W x H)	545 x 220 x 160 mm	710 x 285 x 160 mm
Length of handle	265 mm	465 mm
Pressure relief operating pressure	4 Ton	10 Ton
Pump unit dimensions (L x W x H)	330 x 130 x 140 mm	510 x 130 x 140 mm
Pump rated operating pressure	63 Mpa	62 Mpa
Pump oil capacity	250 g	500 g
Hose dimensions (L x O/D)	1150 x 17 mm	1350 x 17 mm
Hose max operating pressure	20,000 PSI	20,000 PSI
Ram unit length (ret/ext)	270 x 395 mm	358 x 493 mm
Ram rated operating force	4 Tons	10 Tons
Ram piston stroke	125 mm	135 mm
Hydraulic spreader dims (L x W x H)	230 x 50 x 60 mm	230 x 50 x 60 mm
Spreader max rated load	0.5 Ton	0.5 Tons
Spreader opening	16 - 90 mm	16 - 90 mm
Base rated load	4 Tons	10 Tons
Angled toe rated load	4 Tons	4 Tons
Circular head rated load	4 Tons	10 Tons
Square V-head	4 Tons	10 Tons
Rubber head	4 Tons	10 Tons
Plate head	4 Tons	10 Tons
Removable connector	4 Tons	10 Tons
Extension tubes	2 Tons	5 Tons

Please note that the details and specifications contained herein, are correct at the time of going to print. However, OEM reserves the right to change specifications at any time without prior notice.

OEM[®] BODY REPAIR KIT

Unpacking

This complete kit contains the heavy duty hydraulic equipment needed for lifting, pushing, pulling, straightening and spreading. When unpacking, check for damage or short ages etc. Any found should be reported to OEM technical support where the product was originally purchased. This Body Repair Kit is supplied with the following components:

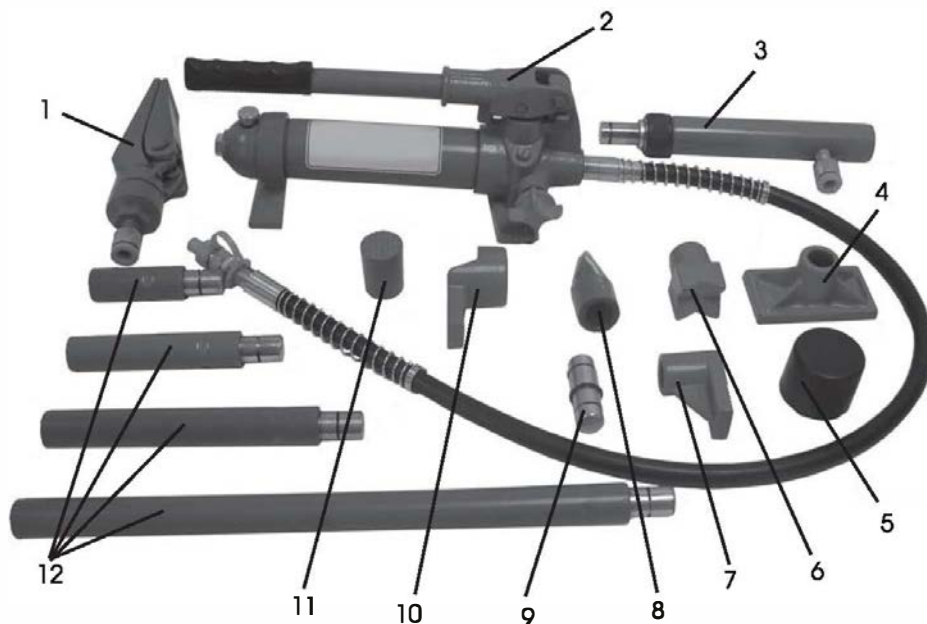

Package Contents

No.	Item	No.	Item
1	Hydraulic Spreader Wedge	7	Plate Head
2	Pump Assembly with Hose	8	Wedge Head
3	Hydraulic Ram	9	Male Connector
4	Flat Base	10	Angled Toe
5	Rubber Head	11	Serrated Cap
6	Square V-Head	12	4 x Extension Tubes

OEM[®] BODY REPAIR KIT

OVERVIEW

This body repair kit is designed for bending chassis frames and repairing dents in vehicle body panels. In most cases, the kit will only return the vehicle body parts to approximately their original position. Additional work will be required to complete the repair. There are two attachments which can be connected to the Pump unit.

- The Hydraulic Ram is for use in larger spaces where greater force is needed and where there is sufficient room. It requires a solid immovable base, directly in line with the damaged area.
- The Spreader Wedge is used in tighter spaces where the Ram and other accessories will not fit.

THE ATTACHMENTS

Several different attachments are provided that may be used in conjunction with the Hydraulic Ram dependant upon the nature of the damage.

- The **FLAT BASE** is used to spread the load of the Hydraulic Ram. It should be connected to the static end of the Hydraulic Ram using the Male Connector.
- The **RUBBER HEAD** is typically used for popping dents out of sheet metal such as doors and body panels when plugged into the moving end of the Hydraulic Ram or the Extension Tubes.
- The **SQUARE V-HEAD** is used to align the force of the Hydraulic Ram when bearing against an angled frame, and may be attached to the Hydraulic Ram or the Extension Tubes.
- The **WEDGE HEAD** is used to repair small dents and areas located in angles and tight spaces and attach es to the Hydraulic Ram or Extension Tubes.

- The **MALE CONNECTOR** plugs into the female end of the Hydraulic Ram.
- The **ANGLED TOE** and **PLATE HEAD** are normally attached to the extension tubes but could be used as a substitute for the flat base if space is limited.
- The **SERRATED CAP** is typically used for pushing during frame repair. It may be plugged into either end of the Hydraulic Ram or the Extension Tubes.
- The **EXTENSION TUBES** plug together in different combinations to reach the desired length.
- The **HYDRAULIC SPREADER WEDGE** is used in restricted spaces when the Hydraulic Ram cannot be used. Connect the wedge directly to the hose of the pump unit.

ASSEMBLY

When assembling the Hydraulic Ram, Pump unit and attachments, unscrew and retain the plastic end plugs on the connections of the Ram and Hydraulic Spreader Wedge for future use. Ensure the hydraulic hose is tightly screwed to the connection.

1. Screw the Pump Handle into the socket in the pump unit.
 2. If the Hydraulic Spreader Wedge is to be used, connect the screw-in connector of the pump hose to the spreader wedge as shown in Fig 1.
 3. If the Ram is to be used, fit the Flat Base to the static end of the Ram using the male connector. Connect other attachments to the moving end as required.
- Various combinations of extension tubes and attachments can be assembled as shown in Fig 2, according to the distance between the work surface and the supporting frame.

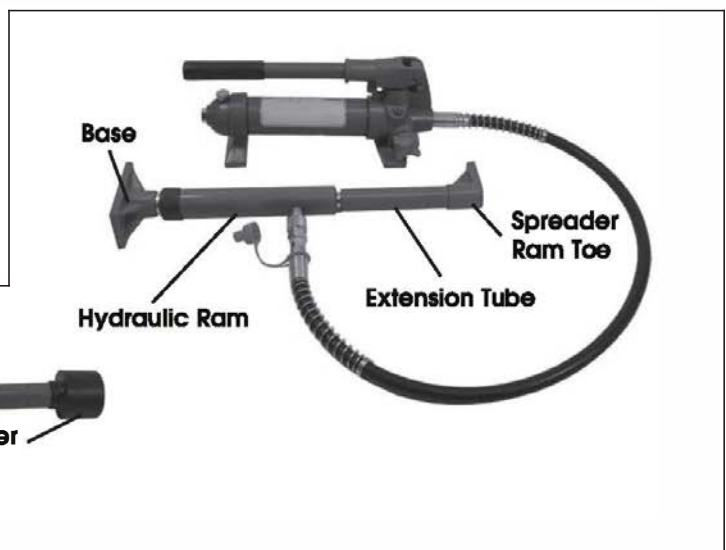
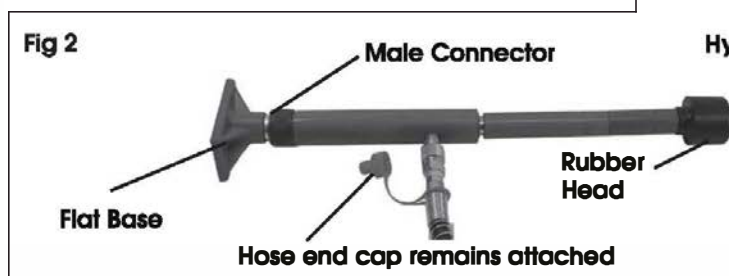

OEM[®] BODY REPAIR KIT

OPERATION

Assemble the components including the flat base and as many extension tubes as required.



NOTE THAT WHEN ADDING FURTHER EXTENSION TUBES, THE MAXIMUM RATED LOAD IS REDUCED. (SEE WARNING LABEL)

1. Connect the Hydraulic Ram or Hydraulic Spreader to the connecting hose using the screw-on hose connector. Use the male connector to join the ram to your selected attachment or any extension tube.
2. To operate the Hydraulic Pump, position it on a stable, level surface close to the damaged area. Close the Release Valve by turning it clockwise and pump the handle to create pressure.
3. Turn the Release Valve counter-clockwise to release the pressure.

- The pump may be positioned horizontally or vertically. When using the Hydraulic Ram in a vertical position, always keep the hose end facing downward.



NEVER OVERLOAD THE RAM BEYOND ITS CAPACITY. ENSURE THE BEARING POINT IS STABLE AND PROPERLY CENTRED ABOVE THE RAM. NEVER OVERLOAD THE ATTACHED COMPONENTS BEYOND THEIR RATED CAPACITIES AS STATED IN THE SPECIFICATION.

Always apply the load slowly to be sure that everything is secure. Take care that the load is always in line with the ram.

USING THE RAM

1. Determine in which direction the target area needs to be pushed.
2. Remove any obstructions that are in the way and could be damaged.
3. Connect the Flat Base to the stationary side of the Hydraulic Ram and connect the appropriate attachment to the working end of the Ram. Note: When repairing larger body panel dents such as a dented door, wing or quarter panel, the correct pushing attachment will be the Rubber Head.
4. Position the Hydraulic Ram so that the flat base is resting against a frame member opposite the damaged area. It must be in line with the direction in which the damaged area needs to be pushed and have enough support that only the damaged area will be displaced by the ram pressure.

- Use soft pads or wooden supports where necessary to protect the body.

5. Aim the pushing end towards the damaged area and slowly apply pressure with the pump.
6. Once contact is established at each end, keep as well clear as practical and slowly apply pressure to the damaged area until the desired correction has been made.



CAUTION: KEEP HANDS AWAY FROM CONTACT AREAS AND TIGHT SPACES IN CASE THE COMPONENTS SHOULD SLIP AND CAUSE INJURY.

7. When the damaged area has been bent to the desired position, slowly turn the release valve on the pump unit in a counterclockwise direction to release hydraulic pressure before removing the Ram.

USING THE SPREADER WEDGE

1. Determine in which direction the metal needs to be spread.
2. Remove any obstructions that are in the way and could be damaged.
3. Place the Spreader Wedge so that the hinged arm is resting against the part to be moved and the stationary base is bearing against a rigid support. Hold the Spreader Ram in position and apply the pump pressure.
4. Once contact is established at each end, keep as well clear as practical and slowly apply pressure to the damaged area until the desired correction has been made.



CAUTION: KEEP HANDS AWAY FROM CONTACT AREAS AND TIGHT SPACES IN CASE THE COMPONENTS SHOULD SLIP AND CAUSE INJURY.

5. When the damaged area has been bent to the desired position, slowly turn the release valve on the pump in a counterclockwise direction to release hydraulic pressure before removing the wedge.

OEM[®] BODY REPAIR KIT

MAINTENANCE

If the pump has been stored for long periods, check the oil level before use. Stand the pump on a level surface and remove the breather valve on the oil reservoir. If necessary, top up via the breather valve which is then screwed on finger tight.

Note: Only unscrew this when the system is not under pressure.

The oil level should be near the bottom of the opening. If required, oil can be Topped. Top using high quality Hydraulic Oil.

After extensive use, the hydraulic oil should be replaced to ensure longer equipment life. Do not overfill, or the piston rod will be unable to move freely. Replace the breather valve after re-filling. The required oil volumes are as follows.

24820 - 250 ml + 5ml
 24821 - 500 ml + 5ml

STORAGE

After use, screw the valve cover on to the pump to keep the connection clear of dust and dirt and cover the hydraulic hose end with the plastic cap. When not in use, the pump should be stored with the release valve open. Store all the equipment in its moulded case in a clean, dry environment protected from the weather.

ENVIRONMENTAL PROTECTION

If disposing of old oil or any damaged components, do not dispose of them with general waste. Any escaping oil should be captured with some absorbent material which should then be disposed of appropriately. This product and its packaging contain valuable raw materials and should be taken to your local civic amenity site for recycling.

SPARE PARTS

In the event of lost or damaged components, replacements are available from OEM Parts & Service. Please refer to the following parts list and diagrams, quoting the OEM part numbers:

4 Ton: 24820-01 to 69.
 10 Ton: 24821-01 to 69.

FAULT FINDING

Problem	Possible Cause	Remedy
Ram does not operate when handle is pumped.	Release valve not tightly closed. Air trapped in system.	Firmly close the release valve. Purge air from system by pumping operating handle.
Ram will not hold load.	Release valve not tightly closed. Malfunction in pump such as dirt inside valve mechanism.	Firmly close the release valve. Return pump to dealer for overhaul.
Ram reluctant to lower when load removed.	Oil reservoir overfilled. Piston binding.	Drain oil to correct level. Clean and lubricate moving parts.
Ram will not extend to full range of stroke	Low oil level.	Add hydraulic oil to the reservoir.
Ram tries to tilt to one side.	Poor positioning of the footing.	Stop work and re-position ram and base, ensuring it is well supported and as close to perpendicular to the repair as possible.

OEM[®] BODY REPAIR KIT

ACCESSORIES

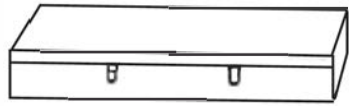

1

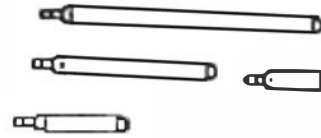

2



3



4



5



6



7



8



9



10

HYDRAULIC PUMP

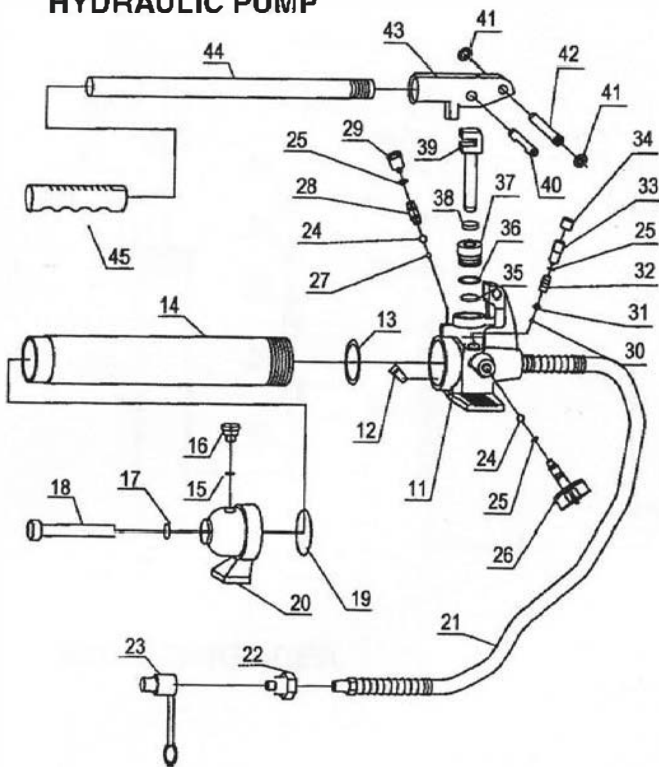

HYDRAULIC RAM

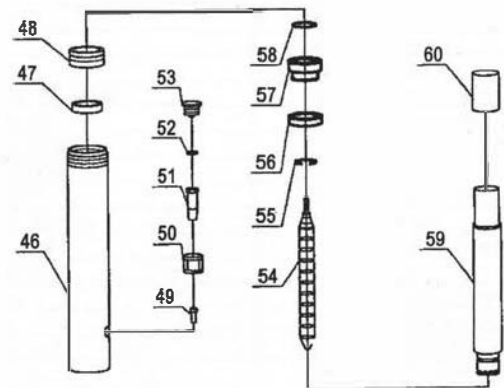

HYDRAULIC SPREADER

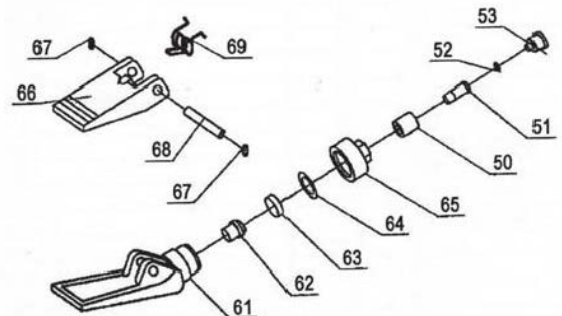

OEM[®] BODY REPAIR KIT

COMPONENT PARTS LIST

No.	Description	No.	Description	No.	Description
1	Plastic Case	24	Steel Ball	47	Ram Cylinder
2	Tube Set (4 pieces)	25	O-ring	48	Screw Cover
3	Flat Base	26	Hand Release Valve	49	Screw M6
4	Angled Toe	27	Sealing Ball	50	Connecting Nut
5	Plate Head	28	Spring	51	Cylinder Screw
6	Wedge Head	29	Screw	52	O-ring
7	Square V-Head	30	Steel Ball	53	Dust Cover
8	Male Connector	31	Ball Cup	54	Tension Spring
9	Serrated Cap	32	Spring	55	Circlip
10	Rubber Head	33	Screw	56	Nylon Sealing Ring
11	Valve Body	34	Screw Protector	57	Bushing
12	Oil Filter	35	O-ring	58	O-ring
13	O-ring	36	Nylon Sealing Ring	59	Piston Rod
14	Oil Reservoir	37	Screw	60	Piston End Cover
15	Seal Ring	38	O-ring Seal	61	Fixed Jaw
16	Thumb Nut	39	Piston	62	Small Piston
17	Sealing Ring	40	Hinge Pin	63	Piston Ring
18	Tie Rod	41	Circlip	64	O-ring
19	O-ring	42	Pivot Pin	65	Screw Cover
20	Pump Foot	43	Handle Socket	66	Moving Jaw
21	Hydraulic Hose	44	Operating Handle	67	Circlip
22	Coupling	45	Handle Grip	68	Hinge Pin
23	Dust Seal	46	Ram Cylinder	69	Spring