

Please read and save these instructions. Read through this owner’s manual carefully before using product. Protect yourself and others by observing all safety information, warnings, and cautions. Failure to comply with instructions could result in personal injury and/or damage to product or property. Please retain instructions for future reference.



PRESS PIN SET

UNPACKING

After unpacking unit, inspect carefully for any damage that may have occurred during transit. Check for loose, missing, or damaged parts. If any damage is observed, a shipping damage claim must be filed with carrier. Do not use Press Pin Set if broken, bent, cracked or damaged parts (including labels) are noted. Any Press Pin Set that appears damaged in any way, operates abnormally or is missing parts should be removed from service immediately. If you suspect that the Press Pin Set was subjected to a shock load (a load that was dropped suddenly, unexpectedly, etc.) immediately discontinue use until it has been checked by a factory authorized service center.

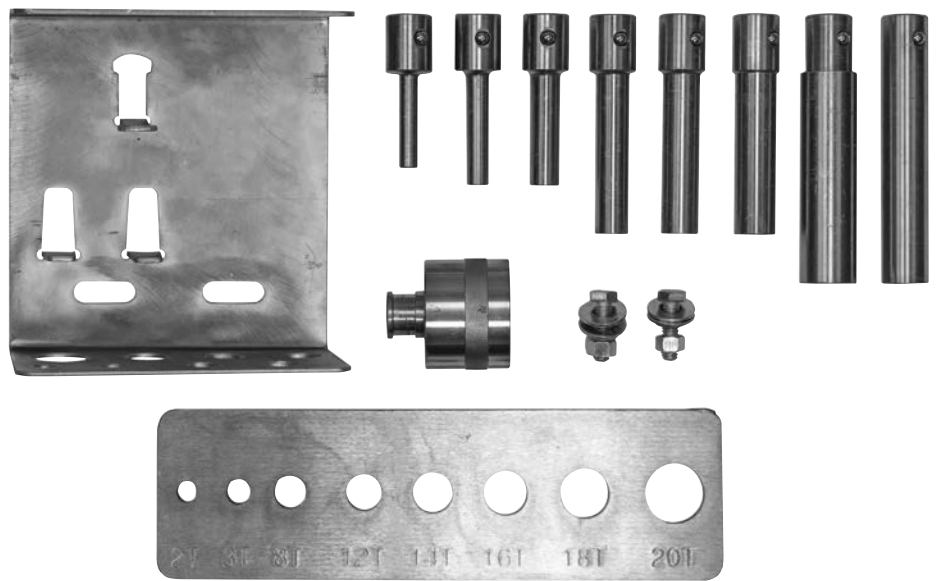

⚠ WARNING

The following safety information is provided as guidelines to help you operate your Press Pin Set under the safest possible conditions. Any tool or piece of equipment can be potentially dangerous to use when safety or safe handling instructions are not known or not followed. The following safety instructions are to provide the user with the information necessary for safe use and operation. Please read and retain these instructions for the continued safe use of your service system. Failure to follow instructions listed below may result in serious injury. In addition, make certain that anyone that uses the equipment understands and follows these safety instructions as well.

WARNING: This product contains chemicals known to the State of California to cause cancer and birth defects or other reproductive harm.

Explanation of Safety Signal Words

⚠ WARNING : Indicates a potentially hazardous situation which, if not avoided, could result in death or serious injury.

⚠ CAUTION : Indicates a potentially hazardous situation which, if not avoided, may result in minor or moderate injury.

CAUTION : Used without the safety alert symbol indicates a potentially hazardous situation which, if not avoided, may result in property damage.

Notes : Provide clarity and helpful information.



PRESS PIN SET

Thank you very much for choosing an OEMTOOLS Product!

For future reference, please complete the owner's record below:

Model: _____ **Purchase Date:** _____

Save the receipt, warranty and these instructions. It is important that you read the entire manual to become familiar with this product before you begin using it. This machine is designed for certain applications only. OEMTOOLS cannot be responsible for issues arising from modification. We strongly recommend this machine is not modified and/or used for any application other than that for which it was designed. If you have any questions relative to a particular application, DO NOT use the machine until you have first contacted OEMTOOLS to determine if it can or should be performed on the product.



IMPORTANT INSTRUCTIONS AND SAFETY RULES

1. Know your tool. Read this manual carefully. Learn the tool's applications and limitations, as well as, potential hazards specific to it.
2. Keep work area clean and well lit. Cluttered or dark work areas invite accidents.
3. Keep children away. All children should be kept away from the work area. Never let a child handle a tool without strict adult supervision.
4. Do not operate this tool if under the influence of alcohol or drugs. Read warning labels on prescriptions to determine if your judgment or reflexes are impaired while taking drugs. If there is any doubt, do not attempt to operate.
5. Use safety equipment. Eye protection should be worn at all times when operating this tool. Use ANSI approved safety glasses. Everyday eyeglasses are NOT safety glasses. Dust mask, non-skid safety shoes, hard hat or hearing protection should be used in appropriate conditions.
6. Wear proper apparel. Loose clothing, gloves, neck-ties, rings, bracelets or other jewelry may present a potential hazard when operating this tool. Keep all apparel clear of the tool.
7. Don't overreach. Keep proper footing and balance at all times when operating this tool.
8. Check for damage. Check your tool regularly. If part of the tool is damaged it should be carefully inspected to make sure that it can perform its intended function correctly. If in doubt, the part should be repaired. Refer all servicing to a qualified technician. Consult your dealer for advice.
9. Keep away from flammables. Do not attempt to operate this tool near flammable materials or combustibles. Failure to comply may cause serious injury or death.
10. Store idle tools out of the reach of children and untrained persons. Tools may be dangerous in the hands of untrained users.
11. Do not use a shop press to compress spring or any other item that could disengage and cause a potential hazard. Never stand directly in front of loaded press and never leave loaded press unattended.
 - Maintain tools with care.
 - Keep tools dry and clean.
 - Properly maintained tools are less likely to bind and are easier to control. Do not use a damaged tool. Tag damaged tools "Do not use" until repaired.
 - Check for misalignment or binding of moving parts, breakage of parts, and any other condition that may affect the tool's operation.
 - If damaged, have the tool serviced before using. Many accidents are caused by poorly maintained tools.
 - Use only accessories that are recommended by the manufacturer for your model. Accessories that may be suitable for one tool may become hazardous when used on another tool.
 - Tool service must be performed only by qualified repair personnel. Service or maintenance performed by unqualified personnel could result in a risk of injury.
 - When servicing a tool, use only identical replacement parts. Use of unauthorized parts or failure to follow maintenance instructions may create a risk of injury.



PRESS PIN SET

- Maintain a safe working environment. Keep the work area well lit. Make sure there is adequate surrounding workspace. Keep the work area free of obstructions, grease, oil, trash, and other debris. Do not use this product in a damp or wet location.
- Maintain labels and nameplates on this product. These carry important information. If unreadable or missing, contact OEM for a replacement.
- Keep the handle dry, clean, and free from brake fluid, oil, and grease.
- Before use, read and understand all warnings, safety precautions, and instructions as outlined in the vehicle manufacturer's service manual. It is beyond the scope of this manual to properly describe the correct procedure and test data for each vehicle.
- Always perform vehicle service in a properly ventilated area. Never run an engine without proper ventilation for its exhaust. Stop work and take necessary steps to improve ventilation in the work area if you develop momentary eye, nose, or throat irritation as this indicates inadequate ventilation.
- Engine parts that are in motion and unexpected movement of a vehicle can injure or kill. When working near moving engine parts, wear snug fit clothing and keep hands and fingers away from moving parts. Keep hoses and tools clear of moving parts. Always stay clear of moving engine parts. Hoses and tools can be thrown through the air if not kept clear of moving engine parts.
- The unexpected movement of a vehicle can injure or kill. When working on vehicles always set the parking brake or block the wheels.
- Avoid accidental fire and/or explosion. Do not smoke near engine fuel and battery components.
- The warnings, precautions, and instructions discussed in this manual cannot cover all possible conditions and situations that may occur. The operator must understand that common sense and caution are factors which cannot be built into this product, but must be supplied by the operator.
- For safety purposes and the prevention of damage to expensive components it is advised that the user have an understanding of basic automotive repair and a working knowledge of automotive systems.
- We believe the information contained herein to be reliable. However, general technical information is given by us without charge and the user shall employ such information at their own discretion and risk. We assume no responsibility for results or damages incurred from the use of such information in whole or in part. Always refer to specific instructions and technical information supplied by vehicle manufacturer.
- The manufacturer declines any and all responsibility for damage to vehicles or components if said damage is the result of unskillful handling by the operator or of failure to observe the basic safety rules set forth in the instruction manual.
- This equipment is intended only for professional use by personnel trained in performing the service functions for which it has been designed
- This equipment is designed for servicing a variety of vehicles in a safe, convenient manner. However, differences in vehicle makes and models may make it impossible to use this equipment as it is intended. Do not attempt to force the use of this equipment on an application for which it is not designed to perform.
- The procedures documented in this manual are to serve as guidelines for the use of this equipment.
- In addition to these guidelines, always follow the manufacturer's recommended procedures when servicing each unique vehicle.
- The use of this equipment is simple and straightforward if you follow the instructions. When operating this equipment, use common sense, and always stop to think before using a Shop Press.

PRODUCT SPECIFICATIONS

Capacity	2-20 Tons
Overall Height	25 mm



PRESS PIN SET

PRODUCT DESCRIPTION

OEMTOOLS 8-piece press accessory kits are designed to be used with presses up to 20 tons. Includes Set of eight press pins, 2-20 ton capacity, with ram adaptor all finished in a yellow phosphate finish for added corrosion resistance. Also, includes mountable bracket. Suitable for use with presses which have a female ram assembly diameter of 25 mm and are secured with a bolt.

NEVER use for any purpose other than those uses outlined above!

Verify that the product and application are compatible.

Before using this product, read the operator's manual completely and familiarize yourself thoroughly with the product, its components and recognize the hazards associated with its use.

Wear appropriate safety gear, including heavy-duty work gloves and ANSI-approved safety goggles during use.

Always evaluate your task before using this press. Use as intended only.

Use only on a hard, level and flat surface capable of bearing the combined weight of the Shop Press, the operator and any tools being used.

TO PREVENT SERIOUS INJURY: DO NOT USE A DAMAGED OR MALFUNCTIONING PRESS

If in doubt about the safety of your project, we advise you to have the work done by a professional familiar with applicable safety practices.

WARNING

Like all shop equipment there is potential danger when operating a shop press. Accidents are frequently caused by lack of familiarity or failure to pay attention. Use this Press Pin Set with respect and caution to decrease the risk of operator injury. If normal safety precautions are overlooked or ignored, serious personal injury may occur.

OPERATION

WARNING

Each pin in the set has its own rating between 2 and 20 Tons. **DO NOT** exceed this rated capacity. Never apply excessive force to a workpiece and always use the pressure gauge to accurately determine the applied load

NEVER stand directly in front of a loaded press and never leave loaded press unattended

AVOID OVERLOAD. Exceeding rated press capacity can damage the press, shatter a workpiece, or launch a press pin causing a severe impact injury. When the press has reached its maximum pressure or the pump lever becomes stiff to operate, the press has reached its limit. Never use a cheater pipe for extra leverage.

OPERATION SAFETY. Applying pressure to parts with a press can cause them to spring out and strike you or bystanders with deadly force. Verify that bystanders are a safe distance away from the press during operations. Make sure that you are wearing leather gloves and safety glasses with a face shield. Heavy leather boots with extra toe protection are also required. Under some conditions, a hard hat may be needed.

WORKPIECE SUPPORT. When a part is pressed free, a workpiece may shift suddenly or fall from the press, causing a crushing injury to your foot or leg. Use a catch basket and support long or awkward workpieces with stands or chains, or have an assistant support the end of a long workpiece during pressing operations.

UNSAFE WORKPIECE. Applying pressure to unstable objects can cause the object to eject, causing an impact injury. Never apply pressure to balls, round objects, springs, or elastic items.

AVOIDING PROJECTILE INJURIES. Being hit by a launched workpiece or press tooling can cause severe impact injury or death. When using a press, stand out of the way of any possible projectile path. Never press with rods or pins that are long enough to shift off-center and kick out under a load. Never stack rods and spacers to create an extended press pin. If pressing must occur with an extended



PRESS PIN SET

press pin, the pin must be fastened with a safety chain or the press pin must be enclosed in a safety cage to eliminate a projectile hazard.

CORRECT TOOLING. Without using the correct spring caging tool or jig to hold the spring-loaded workpiece, the workpiece may shift suddenly, launching springs that could cause a severe impact injury. Never use this press to unload spring-loaded assemblies without also using the correct spring caging tool or jig.

CORRECTING MISALIGNED LOADS. If a workpiece becomes misaligned during pressing operations, it may slip out of the press and cause severe impact injury. Never attempt to realign a workpiece while it is under pressure. Relieve hydraulic pressure, and start pressing operations over if a workpiece or press pin has moved or become misaligned. Relieve hydraulic pressure if you suspect the workpiece is in a bind, or structural failure is imminent.

SAFE WORKING ZONE. Falling tooling, arbor plates, or a shifting workpiece can cause a crushing injury to your leg or foot. Keep out from under the bed, do not work under the press when it is loaded, and never leave the press loaded and unattended.

AVOIDING INCORRECT PRESS OPERATIONS. Some workpieces cannot withstand the force of pressing and can explode, causing an impact injury. Other workpieces have hidden retaining rings, shoulders, pins, welds, or are integral and cannot be pressed apart. Before using this press, make sure that you understand how a component is built and pressed apart.

AVOIDING SPRING-BACK HAZARDS. Under heavy pressing operations, when some parts finally break free of the host workpiece, sudden hydraulic press unloading can result in spring-back. As a result, a workpiece, press pin, or arbor plate can spring up and fall from the bed, causing a crushing injury to your foot or leg. Before press operations begin, anticipate what the workpiece may do if this sudden unloading occurs, and secure the workpiece so it will not fall.

1. Make sure the press will accept the Ram Adapter and fasten securely with a bolt. The shop press ram must have a 25 mm female hole with set screw.
2. Install Ram Adapter and tighten set screw. Select desired Pin and insert into the Ram Adapter, making sure it is fully bottomed out in the Adapter and secured by the Retaining Ball on the Pin.
3. Following directions provided by the press manufacturer, apply pressure to the workpiece as desired.

WARNING

DO NOT EXCEED PRESSURE RATING MARKED ON THE PIN HOLDER BRACKET

EXCEEDING RATED PRESS PIN CAPACITY CAN DAMAGE THE PRESS PIN, SHATTER A WORKPIECE, OR LAUNCH A PRESS PIN CAUSING A SEVERE IMPACT INJURY



PRESS PIN SET

Figure	Description	Quantity
24813-1	Press Pin 2 Ton	1
24813-2	Press Pin 3 Ton	1
24813-3	Press Pin 8 Ton	1
24813-4	Press Pin 12 Ton	1
24813-5	Press Pin 14 Ton	1
24813-6	Press Pin 16 Ton	1
24813-7	Press Pin 18 Ton	1
24813-8	Press Pin 20 Ton	1
24813-9	Adapter	1
24813-10	Bracket	1
24813-11	Mounting Plate	1

Note: Not all components of the Press Pin Set are replacement items, but are illustrated as a convenient reference for location and position in the assembly sequence

The manufacturer and/or distributor have provided the parts list and assembly diagram in this manual as a reference tool only. Neither the manufacturer nor distributor makes any representation or warranty of any kind to the buyer that he or she is qualified to make any repairs to the product, or that he or she is qualified to replace any parts of the product. In fact, the manufacturer and/or distributor expressly states that all repairs and parts replacements should be undertaken by certified and licensed technicians, and not by the buyer. The buyer assumes all risk and liability arising out of his or her repairs to the original product or replacement parts thereto, or arising out of his or her installation of replacement parts thereto.

MAINTENANCE

Before each use, inspect Press Pin Set for damage. Do not use if bent, broken, cracked, leaking or otherwise damaged components are noted.

