

Please read and save these instructions. Read through this owner's manual carefully before using product. Protect yourself and others by observing all safety information, warnings, and cautions. Failure to comply with instructions could result in personal injury and/or damage to product or property. Please retain instructions for future reference.

**OEM**<sup>®</sup>  
Tools for Professionals

## 20 TON SHOP PRESS

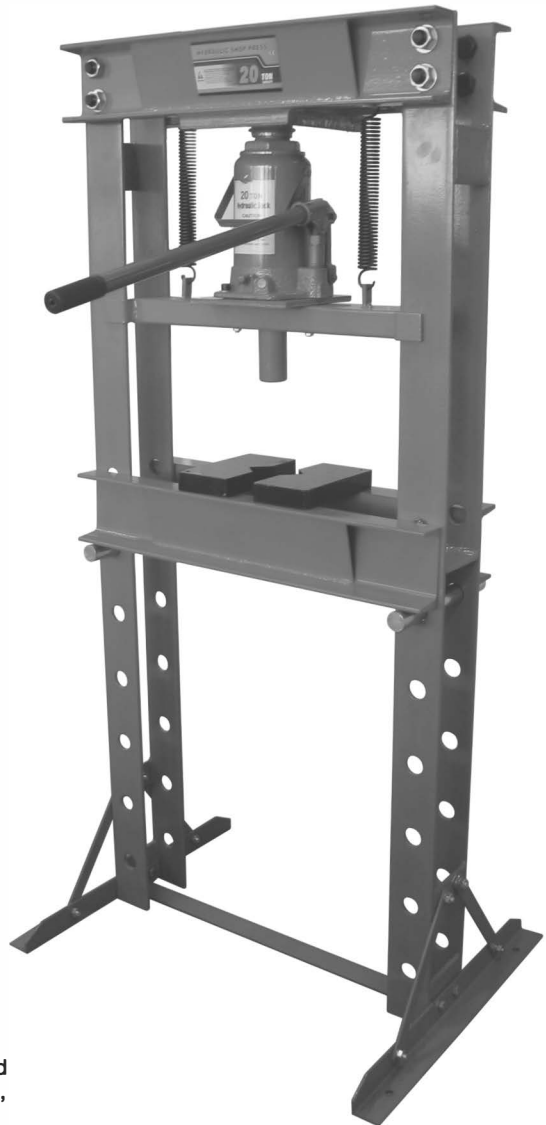

### **Unpacking**

After unpacking unit, inspect carefully for any damage that may have occurred during transit. Check for loose, missing, or damaged parts. Shipping damage claims must be filed with carrier.



# 20 TON SHOP PRESS

## PARAMETER

CAPACITY .....20 TON  
 WORKING RANGE .....0-800MM  
 WIDTH .....530MM

## FEATURE

1. Used for parts straightening, bending and pressing.
2. Multi-position bed for work height adjustment.

## ASSEMBLY



The main frame (part 2, 6 and 10) must be assembled by at least two persons. Please note that the pole (part 2) will easily fall down during assembly.

Assemble the main frame (figure-1)

1. Connect the angle plate (part 6) to the leg (part 10) with supplied bolts. Loose tighten the bolts (don't fully tighten the bolts).
2. Connect the pole (part 2) to the angle plate (part 6) and the leg (part 10) with supplied bolts. Loose tighten the bolts (don't fully tighten the bolts).
3. Adjust the pole (part 2) and the angle plate (part 6) to make sure that the pole (part 2) is perpendicular to the ground.
4. Fully tighten all the bolts.



figure-1

Assemble the jack (figure-2 and figure-3)

1. Connect the springs (part 14) to the jack plate (part 3) and cross beam (part 1). The hook on one side of the springs (part 14) should be connected to the holes on the jack plate (part 3). The hook on the other side of the springs (part 14) should be connected to the cross beam (part 1) directly.
2. Press the jack plate (part 3) downwards to put the jack (part 15) between the jack plate (part 3) and the cross beam (part 1). The hydraulic pressure spindle on the jack should be inserted into the hole of the cross beam (part 1). The two holes on the bottom of the jack (part 15) should be aligned with the two holes on the jack plate (part 3).
3. Insert the two bolts (part 16) into the two holes on the bottom of the jack (part 15) and fully tighten them.



figure-2



figure-3



# 20 TON SHOP PRESS

## OPERATION

1. Place work piece on bed frame.
2. Locate and close release valve by turning it clockwise until tight.
3. Pump handle until the ram nears work piece.
4. Align ram and work piece to ensure center loading.
5. Apply load to work piece by pumping handle. Do not overload work piece.
6. Remove load from work piece by turning release valve counterclockwise. Stabilize work piece so it does not fall while pressure is released.
7. Remove work piece after ram is fully retracted.



1. Read and understand the entire instruction manual before attempting setup, or operation of this machine.
2. This press is designed and intended for use by properly trained and experienced personnel only. If you are not familiar with the proper and safe operation of a hydraulic press, do not use until proper training and knowledge has been obtained.
3. Do not operate this press beyond it rated capacity.
4. This press is designed for pressing, bending, and straightening purposes only. DO NOT compress springs or other objects that could be ejected from the press. DO NOT compress objects that could shatter.
5. Check the press for loose or damaged parts before each operation. Replace damaged parts and tighten all loose bolts before operating.
6. Some parts being pressed may have a tendency to pop out of the press or explode under pressure. Protect yourself accordingly. Keep hands away from the pressure head and out of support rod holes. Always center the work piece on the table plates and center the pressure head on the work piece to prevent injury by ejection of the work piece.
7. Always wear safety glasses I face shields and personal safety equipment.

## MAINTENANCE

1. Before each use inspect press for damage. Do not use if bent, broken, cracked, leaking or otherwise damaged in any way.
2. Periodically, lightly oil all moving parts including the pump piston and hydraulic ram.
3. Check hydraulic connections and hoses before each use. Do not use if cut, damaged, leaking or otherwise damaged connections and/or hoses are noted.

## TROUBLESHOOTING

1. Assemble it according to the instructions given below.
2. Sit it on a firm, flat, level surface in a well ventilated area and away from any open flames.
3. Follow the degreaser manufacturer's instructions carefully.
4. Do not fill with flammable solvents such as kerosene, gasoline, etc.

Symptom	Possible	Corrective Action
Plunger can not be moving	The mechanical parts are corrupt	Add lubricate oil or grease
Plunger can not be auto retracted or retract slowly	1. Reservoir overfilled 2. Linkages binding	1. Drain jack oil to proper level 2. Clean and lubricate moving parts
Will not lift to full extension	Jack oil level low	Add jack oil

**OEM<sup>®</sup>**

**20 TON SHOP PRESS**

**PARTS LIST AND DIAGRAM**

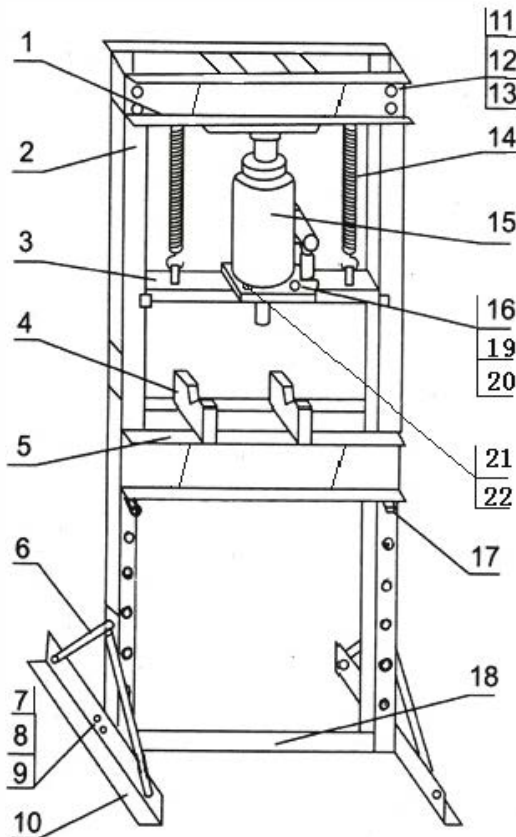

Reference No.	Description	Qty	Reference No.	Description	Qty
24810-1	CROSS BEAM	1	24810-12	WASHER	4
24810-2	POLE	2	24810-13	NUT	4
24810-3	JACK PLATE	1	24810-14	SPRING	2
24810-4	STEEL PLATE	2	24810-15	JACK	1
24810-5	ADJUST BEAM	1	24810-16	BOLT	2
24810-6	ANGLE PLATE	4	24810-17	PIN	2
24810-7	BOLT	12	24810-18	FIX PLATE	1
24810-8	WASHER	12	24810-19	WASHER	2
24810-9	NUT	12	24810-20	NUT	2
24810-10	LEG	2	24810-21	BOLT	2
24810-11	BOLT	8	24810-22	WASHER	2



# 20 TON SHOP PRESS

