

Please read and save these instructions. Read through this owner's manual carefully before using product. Protect yourself and others by observing all safety information, warnings, and cautions. Failure to comply with instructions could result in personal injury and/or damage to product or property. Please retain instructions for future reference.



## 1/4" MINI ANGLE AIR DIE GRINDER

### UNPACKING

After unpacking unit, inspect carefully for any damage that may have occurred during transit. Check for loose, missing, or damaged parts. If any damage is observed, a shipping damage claim must be filed with carrier. Do not use the OEMTOOLS® Angle Air Die Grinder if broken, bent, cracked or damaged parts (including labels) are noted. Any Angle Air Die Grinder that appears damaged in any way, operates abnormally or is missing parts should be removed from service immediately. If you suspect that the Angle Air Die Grinder was subjected to shock load (a load that was dropped suddenly, unexpectedly, etc.) immediately discontinue use until it has been checked by a factory authorized service center.



### ⚠ WARNING

The following safety information is provided as a guideline to help you operate your Angle Air Die Grinder under the safest possible conditions. Any tool or piece of equipment can be potentially dangerous to use when safety or safe handling instructions are not known or not followed. The following safety instructions are to provide the user with the information necessary for safe use and operation. Please read and retain these instructions for the continued safe use of your tool. Failure to follow instructions listed below may result in serious injury. In addition, make certain that anyone that uses the equipment understands and follows these safety instructions as well.

### Explanation of Safety Signal Words

**⚠ WARNING** : Indicates a potentially hazardous situation which, if not avoided, could result in death or serious injury.

**⚠ CAUTION** : Indicates a potentially hazardous situation which, if not avoided, may result in minor or moderate injury.

**CAUTION** : Used without the safety alert symbol indicates a potentially hazardous situation which, if not avoided, may result in property damage.

**NOTES** : Provide clarity and helpful information.

Thank you very much for choosing an OEMTOOLS Product!

For future reference, please complete the owner's record below:

**Model:** \_\_\_\_\_ **Purchase Date:** \_\_\_\_\_

Save the receipt, warranty and these instructions. It is important that you read the entire manual to become familiar with this product before you begin using it. This tool is designed for certain applications only. OEMTOOLS cannot be responsible for issues arising from modification. We strongly recommend this tool is not modified and/or used for any application other than that for which it was designed. If you have any questions relative to a particular application, DO NOT use the tool until you have first contacted customer service to determine if it can or should be performed on the product.



## 1/4" MINI ANGLE AIR DIE GRINDER



### IMPORTANT INSTRUCTIONS AND SAFETY RULES

1. Know your tool. Read this manual carefully. Learn the tool's applications and limitations, as well as, potential hazards specific to it.
2. Keep work area clean and well lit. Cluttered or dark work areas invite accidents.
3. Keep children away. All children should be kept away from the work area. Never let a child handle a tool without strict adult supervision.
4. Do not operate this tool if under the influence of alcohol or drugs. Read warning labels on prescriptions to determine if your judgment or reflexes are impaired while taking drugs. If there is any doubt, do not attempt to operate.
5. Use safety equipment. Eye protection should be worn at all times when operating this tool. Use ANSI approved safety glasses. Everyday eyeglasses are NOT safety glasses. Dust mask, non-skid safety shoes, hard hat or hearing protection should be used in appropriate conditions.
6. Wear proper apparel. Loose clothing, gloves, neck-ties, rings, bracelets or other jewelry may present a potential hazard when operating this tool. Keep all apparel clear of the tool.
7. Don't overreach. Keep proper footing and balance at all times when operating this tool.
8. Check for damage. Check your tool regularly. If part of the tool is damaged it should be carefully inspected to make sure that it can perform its intended function correctly. If in doubt, the part should be repaired. Refer all servicing to a qualified technician. Consult your dealer for advice.
9. Keep away from flammables. Do not attempt to operate this tool near flammable materials or combustibles. Failure to comply may cause serious injury or death.
10. Store idle tools out of the reach of children and untrained persons. Tools may be dangerous in the hands of untrained users.
11. Maintain tools with care.
12. Keep tools dry and clean.
13. Do not use a damaged tool. Tag damaged tools "Do not use" until repaired.
14. Use only accessories that are recommended by the manufacturer for your model. Accessories that may be suitable for one tool may become hazardous when used on another tool.
15. Tool service must be performed only by qualified repair personnel. Service or maintenance performed by unqualified personnel could result in a risk of injury.
16. When servicing a tool, use only identical replacement parts. Use of unauthorized parts or failure to follow maintenance instructions may create a risk of injury.
17. Maintain a safe working environment. Keep the work area well lit. Make sure there is adequate surrounding workspace. Keep the work area free of obstructions, grease, oil, trash, and other debris. Do not use this product in a damp or wet location.
18. Maintain labels and nameplates on this product. These carry important information. If unreadable or missing, contact customer service.
19. Before use, read and understand all warnings, safety precautions, and instructions as outlined in the vehicle manufacturer's service

manual. It is beyond the scope of this manual to properly describe the correct procedure and test data for each vehicle.

20. Always perform vehicle service in a properly ventilated area. Never run an engine without proper ventilation for its exhaust. Stop work and take necessary steps to improve ventilation in the work area if you develop momentary eye, nose, or throat irritation as this indicates inadequate ventilation.

### WARNING

- Disconnect from air supply before changing accessories or servicing.
- Check correct air pressure is maintained and not exceeded.
- Due to possible presences of asbestos dust from brake linings, when working around vehicle brake systems we recommend you wear suitable respiratory protection.

**NOTE:** The manufacturer declines any and all responsibility for damage to vehicles or components if said damage is the result of unskillful handling by the operator or of failure to observe the basic safety rules set forth in the instruction manual.

### WARNING

Read Rules for Safe Operation and Instructions Carefully.

### IMPORTANT SAFETY INSTRUCTIONS

The warnings, precautions, and instructions discussed in this manual cannot cover all possible conditions and situations that may occur. The operator must understand that common sense and caution are factors which cannot be built into this product, but must be supplied by the operator.

### WARNING

1. Use only attachments recommended or sold by manufacturer. Use of non-recommended attachments may result in fire, electric shock or injury.
2. Do not disassemble the Angle Air Die Grinder. Take it to a qualified professional when service or repair is required.
3. Keep air hose away from heat, oil and sharp edges. Check air hose for wear before each use and ensure that all connections are secure.
4. Only use accessories that are specifically designed for use with an Angle Air Die Grinder.
5. Wear approved safety eye/face shield, ear defenders and hand protection.
6. When not in use disconnect from air supply and store in a safe dry, childproof location.
7. DO NOT use the Angle Air Die Grinder for tasks it is not designed to perform.
8. DO NOT carry the Angle Air Die Grinder by the air hose, or yank the hose from the air supply.
9. DO NOT operate the Angle Air Die Grinder if you are tired or under the influence of alcohol, drugs or intoxicating medication.
10. DO NOT direct air from the air hose at yourself or others.

### DISPOSAL

At the end of the useful life of the OEMTOOLS Angle Air Die Grinder, dispose of the components according to all state, federal, and local regulations.



# 1/4" MINI ANGLE AIR DIE GRINDER

## PURPOSE

The 24407 1/4" Mini Angle Air Die Grinder has an ultra-compact body and is designed for sanding, polishing, smoothing rough areas, grinding and carving in confined spaces.

## PRODUCT SPECIFICATIONS

<b>Collet Size:</b>	1/4"
<b>Free Speed:</b>	18,000 RPM
<b>Air Consumption:</b>	2.8 CFM
<b>Lightweight:</b>	0.9 Lbs. (0.4 kg)
<b>Air Inlet Thread Size:</b>	1/4" Drive
<b>Recommended Air Pressure:</b>	90 Psi
<b>Length:</b>	6.4" (126 mm)
<b>Exhaust:</b>	Front
<b>Angle:</b>	90 Degrees

## ⚠️ WARNING

Ensure the air supply is clean and does not exceed 90 Psi while operating the Angle Air Die Grinder. Excessive wear will result if air pressure is too high and/or you use unclean air. This can shorten the product life and may be dangerous causing damage and/or personal injury.

## OPERATING INSTRUCTIONS

### ⚠️ WARNING

Ensure you read, understand and apply safety instructions before use.

1. Always inspect, maintain and operate in accordance with ANSI safety code for portable air tools (ANSI B186.1) and other local safety codes and regulations.
2. Do not operate this tool over 90 Psi air pressure.
3. Always disconnect this tool from the air supply before installing, adjusting or removing any accessory from this tool or before performing maintenance.
4. Do not carry any air tool by the hose. Keep air hose away from heat and sharp objects.
5. Continuous use of vibrating air tools by susceptible users may cause damage to hands.
6. Always lubricate and maintain the tool in safe operating condition.
7. Only use accessories which are specifically designed for use with an Angle Air Die Grinder.
8. Connect the Angle Air Die Grinder to the air hose.

## AIR SUPPLY

Ensure that the Angle Air Die Grinder air valve (or trigger) is in the "off" position before connecting to the air supply. Always use clean dry air as excessive moisture will lower the available torque and rust the interior moving parts. Make sure all hoses and fittings are of the recommended size and be sure the units are not used with less than or more than the recommended pressure of the tool (90 Psi).

## LUBRICATION

Proper lubrication of this air tool is critical to the operation and life of the unit. Units can be severely damaged or have excessive wear placed on working parts if not lubricated. We recommend the use of air tool oil or 3-in-1 machine oil which is available at most auto parts locations. The tool should be lubricated each time it is used. During daily prolonged use, lube heavily 3 or 4 times during the day.

## ⚠️ WARNING

Any excess oil in the motor is immediately expelled from the exhaust port. Always direct exhaust port away from people or objects.

## MAINTENANCE

### ⚠️ WARNING

Disconnect the Angle Air Die Grinder from air supply before changing accessories, servicing or performing maintenance.

1. Replace or repair damaged parts. Use genuine parts only. Unauthorized parts may be dangerous and will invalidate the warranty.
2. If the air system does not have an oiler then lubricate the Angle Air Die Grinder daily with a few drops of air tool oil into the air inlet.
3. Blow out air line to clear it of accumulated dirt and moisture.
4. Connect tool and operate tool to allow oil to be carried to the interior of the tool.
5. Clean the Angle Air Die Grinder after use.
6. DO NOT use worn or damaged attachments.

## TROUBLESHOOTING

Problem	Cause	Remedies
Unit will not work	Plugged air inlets	Remove fitting and clean
	Interior is rusted	Disassemble, clean, lube and reassemble
Unit lacks power	Low air supply	Check hoses, tanks, etc.
	Lack of lubrication	Lube properly and retry
Internal parts	Dirty and gummed	Disassemble, clean, lube
	Components worn	Disassemble, determine parts requiring replacement and repair





# 1/4" MINI ANGLE AIR DIE GRINDER

## Parts List

Item #	Part Name	Qty.
1	Housing	1
2	Trigger Assembly	1
3	Pin	1
4	O-Ring	1
5	O-Ring	1
6	Valve Stem	1
7	Valve Spring	1
8	Air Regulator	1
9	O-Ring	1
10	O-Ring	1
11	Valve Plug	1
12	Cylinder Assembly	1
12.1	Bearing	1
12.2	End Plate	1
12.3	Set Pin	1
12.4	Rotor	1
12.5	Rotor Blade	4
12.6	Cylinder	1
12.7	Rotor Spacer	1
12.8	Front Plate	1
12.9	Pin	1
12.10	Bearing	1
12.11	Gear	1
13	Retainer	1
14	Hex Nut	1
15	Angle Head	1
16	Grease Cap	1
17	Bearing	1
18	Gear	1
19	Bearing	1
20	Lock Nut	1
21	Key	1
22	Work Spindle	1
23	Collet	1
24	Collet Nut	1

## Parts Diagram

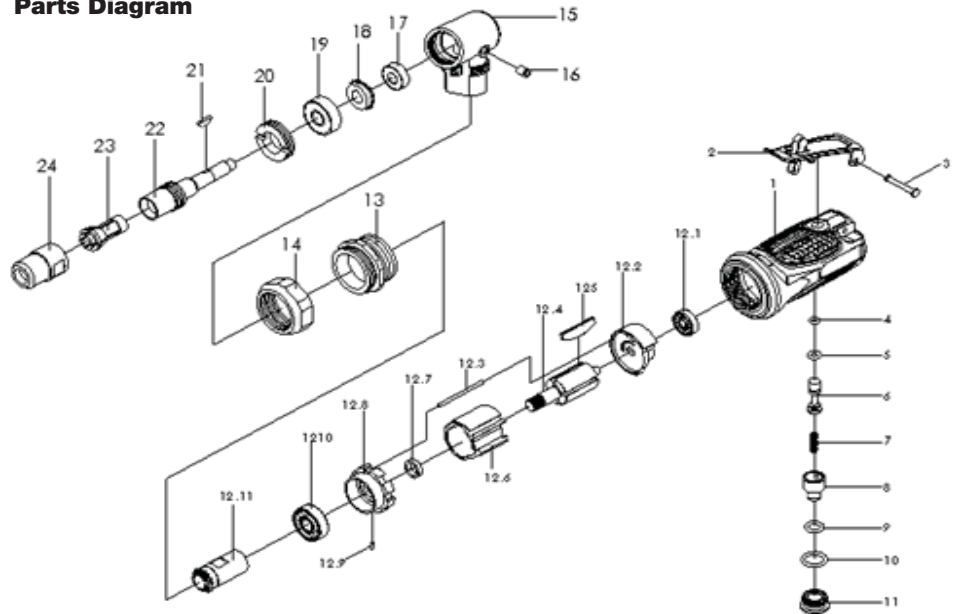

### NOTE:

Not all components of the Mini Angle Air Die Grinder are replacement items, but are illustrated as a convenient reference for location and position in the assembly sequence. OEM and/or its distributors have provided the parts list and assembly diagram as a reference only. Neither OEM and/or its distributors make any representation or warranty of any kind to the buyer and/or user of this tool that he or she is qualified to do any repairs or replace any parts of this product. OEM and its distributors expressly state that all repairs or parts replacement should be done by certified or licensed technicians. The buyer assumes all risk and liability arising out of his or her repairs or parts replacement to the original production