

Owner's Manual & Safety Instructions

Save This Manual Keep this manual for the safety warnings and precautions, assembly, operating, inspection, maintenance and cleaning procedures. Write the product's serial number in the back of the manual near the assembly diagram (or month and year of purchase if product has no number). Keep this manual and the receipt in a safe and dry place for future reference.

OEM TOOLS

#24358

AUTO DARKENING WELDING HELMET







⚠ WARNING

Read this material before using this product.
Failure to do so can result in serious injury.
SAVE THIS MANUAL.

Table of Contents

Safety.....	3	Maintenance.....	9
Specifications.....	5	Parts List and Diagram.....	10
Operation.....	6		





WARNING SYMBOLS AND DEFINITIONS	
	This is the safety alert symbol. It is used to alert you to potential personal injury hazards. Obey all safety messages that follow this symbol to avoid possible injury or death.
	Indicates a hazardous situation which, if not avoided, will result in death or serious injury.
	Indicates a hazardous situation which, if not avoided, could result in death or serious injury.
	Indicates a hazardous situation which, if not avoided, could result in minor or moderate injury.
	Addresses practices not related to personal injury.

IMPORTANT SAFETY INFORMATION

When using helmet, basic safety precautions should always be followed to reduce the risk of personal injury and damage to equipment.

The warnings, cautions, and instructions discussed in this instruction manual cannot cover all possible conditions and situations that may occur. It must be understood by the operator that common sense and caution are factors which cannot be built into this product, but must be supplied by the operator.

Read all instructions before using this helmet!

WARNING	
	
INHALATION HAZARD: Welding and Plasma Cutting Produce TOXIC FUMES.	
Exposure to welding or cutting exhaust fumes can increase the risk of developing certain cancers, such as cancer of the larynx and lung cancer. Also, some diseases that may be linked to exposure to welding or plasma cutting exhaust fumes are:	
<ul style="list-style-type: none">• Early onset of Parkinson's Disease• Heart disease • Ulcers• Damage to the reproductive organs• Inflammation of the small intestine or stomach • Kidney damage• Respiratory diseases such as emphysema, bronchitis, or pneumonia	
Use natural or forced air ventilation and wear a respirator approved by NIOSH to protect against the fumes produced to reduce the risk of developing the above illnesses.	

1. **Do not use the Welding Helmet if the lens is cracked, if the lens or sensors are dirty, or if the lens or front retaining frame is loose.**
2. **Keep work area clean.** Cluttered areas invite injuries.
3. **Observe work area conditions.** Do not use welding helmets in damp or wet locations. Do not expose to rain. Keep work area well lit. Do not use auto-darkening helmets in the presence of flammable gases or liquids.
4. **Keep children away.** Children must never be allowed in the work area. Do not let them handle this helmet.
5. **Store idle equipment.** When not in use, helmets must be stored in a dry location to inhibit rust. Always lock up helmets and keep out of reach of children.
6. **Dress properly.** Do not wear loose clothing or jewelry as they can be caught in moving parts.

Protective gear is essential to protect against welding rays, some examples are: a leather welding apron, welding sleeves, jeans without cuffs, work boots. Wear restrictive hair covering to contain long hair.

7. **Use eye and ear protection.** When welding, wear ANSI-approved impact safety goggles under the Welding Helmet. Wear a NIOSH-approved respirator and hearing protection when welding.
8. **Stay alert.** Watch what you are doing, use common sense. Do not weld when you are tired.
9. **Check for damaged parts.** Before using any helmet, any part that appears damaged should be carefully checked to determine that it will operate properly and perform its intended function. Check for alignment and binding of moving parts; any broken parts or mounting fixtures; and any other condition that may affect proper operation. Any part that is damaged should be properly repaired or replaced by a qualified technician. Do not use the helmet if any switch does not operate properly.
10. **Replacement parts and accessories.** When servicing, use only identical replacement parts. Use of any other parts can render helmet ineffective, possibly causing eye damage, and will void the warranty. Only use accessories intended for use with this helmet.
11. **Do not weld if under the influence of alcohol or drugs.** Read warning labels on prescriptions to determine if your judgment or reflexes are impaired while taking drugs. If there is any doubt, do not weld.
12. **Maintenance.** For your safety, service and maintenance should be performed regularly only by a qualified technician.
13. **This helmet provides protection for intended purposes only.** There are certain applications for which this helmet was designed. Do not modify this helmet and do not use this helmet for a purpose for which it was not intended.
 - a. **The Welding Helmet** is not suitable for laser welding or Oxyacetylene Welding/Cutting processes.

- b. **The Welding Helmet** will not protect against severe impact hazards.
 - c. **The Welding Helmet** will not protect against explosive devices or corrosive liquids.
- 14. Use only at temperatures within the operating range for your model as stated on the specifications chart in this manual.**
15. Maintain the helmet and lens correctly to help ensure reliable protection.
- a. Clean filter's surfaces regularly. Keep sensors and solar cells clean using a clean lint-free tissue/cloth. Do not use any solvents on filter's screen or helmet components. Protect filter from liquid and dirt contact. Do not immerse the filter in water.
 - b. Should the Auto-Darkening Welding Helmet not darken upon striking an arc, stop welding immediately and have the helmet checked by a qualified service technician.
- c. Regularly replace the Front Lens Cover if it becomes cracked, scratched, pitted, or otherwise damaged.
 - d. Do not make any modifications to either the Auto- Darkening Filter or the rest of the helmet, other than those specified in this manual. Do not use any replacement parts other than those specified in this manual. Unauthorized modifications and replacement parts will void the warranty and expose the user to the risk of personal injury. Do not open or tamper with the Auto-Darkening Filter.
16. Do not place the Welding Helmet's Auto-Darkening Filter on a hot surface.
- 17. SEVERE PERSONAL INJURY and/or BLINDNESS may occur if the user fails to follow the aforementioned warnings and/or fails to follow the operation instructions.**

 **SAVE THESE INSTRUCTIONS.**



Operating Instructions



Read the **ENTIRE IMPORTANT SAFETY INFORMATION** section at the beginning of this manual including all text under subheadings therein before set up or use of this product.

Function

The Auto-Darkening Welding Helmet is designed to protect the eyes and face from sparks, splatter, and harmful radiation under normal welding conditions. The Auto-Darkening Filter automatically changes from a clear state to a dark state when an arc is struck, and it returns to the clear state when welding stops.

Before Welding

The Auto-Darkening Welding Helmet comes ready for use. The only things you need to do before welding are to remove the protective film from both sides of the lens (if not already done), adjust the position of the headband, select the correct shade number for your application, and test the helmet for proper operation as described following.

Check the Front Cover Lens to make sure that it is clean, and that no dirt is covering the two sensors on the front of the Filter Cartridge. Also check the Front/Inside Cover Lens and the Front Lens Retaining Frame, and make sure that they are secured in place. Inspect all operating parts before each use for signs of wear or damage. Any scratched, cracked, or pitted parts should be replaced immediately before using again to avoid severe personal injury.

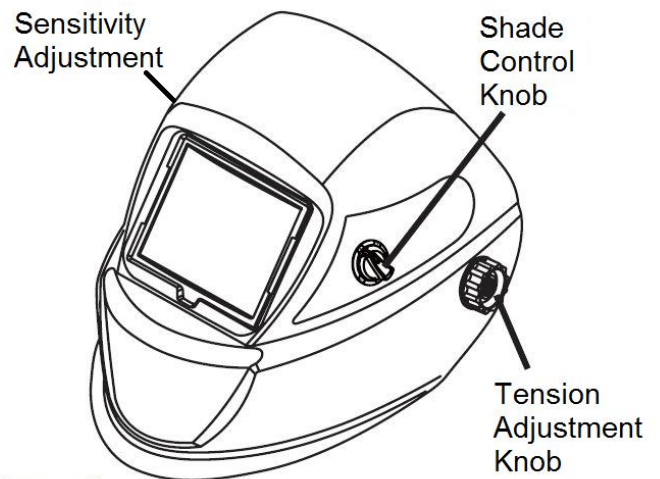

Figure A

Shade Number and Grinding Mode Selection

1. Select the shade number you need (see Shade Guide Chart on the previous page) by turning the Shade Control Knob. Be sure that the shade number of the Welding Helmet is the correct shade number for your application.
2. **Note:** If a selection of shades are recommended for your application, try the darkest setting first.
3. The shade number can be set from 9 to 13 by turning the Shade Control Knob until the arrow points to the desired shade number. See Figure B.
4. Remember to check with the Shade Guide Chart on the previous page to determine the proper shade number for your application.
5. **Important Note:** Test the helmet auto-darkening filter lens before welding. While wearing the helmet, briefly strike an arc, keeping your face and eyes turned slightly away, and to one side. The lens should darken evenly when not directly facing the arc. If it does not darken properly, do not use the Welding Helmet.

Grind Mode Setting

To change to Grinding Mode, rotate the Shade Control Knob counterclockwise to **Grind**. This turns off the shade function so the helmet lens stays clear. Use this function to provide protection while grinding.

CAUTION! Set the helmet to the proper shade setting before welding again.

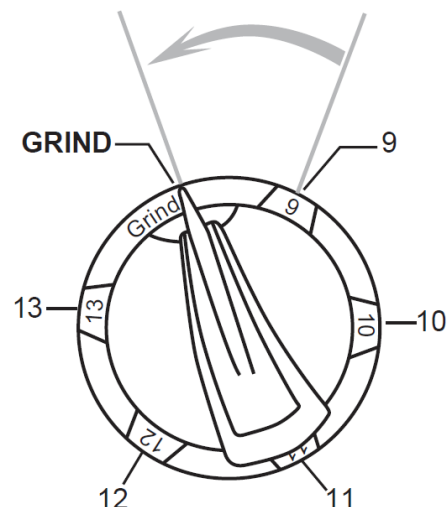

Figure B

Adjusting Headband

Adjust the headband so that the helmet is seated securely on your head as low as possible and close to your face.

Adjust the headband width by turning the Ratcheting Headband Knob to make sure the Front Cover Lens is aligned with your eyes.

Adjust the headband height by tightening or loosening the top strap until the helmet fits snug on your head. Once the headband is properly adjusted, lower the helmet over your face until the proper angle is found. Then turn the Tension Adjustment Knobs on either side of the helmet, locking the helmet's angle in place.

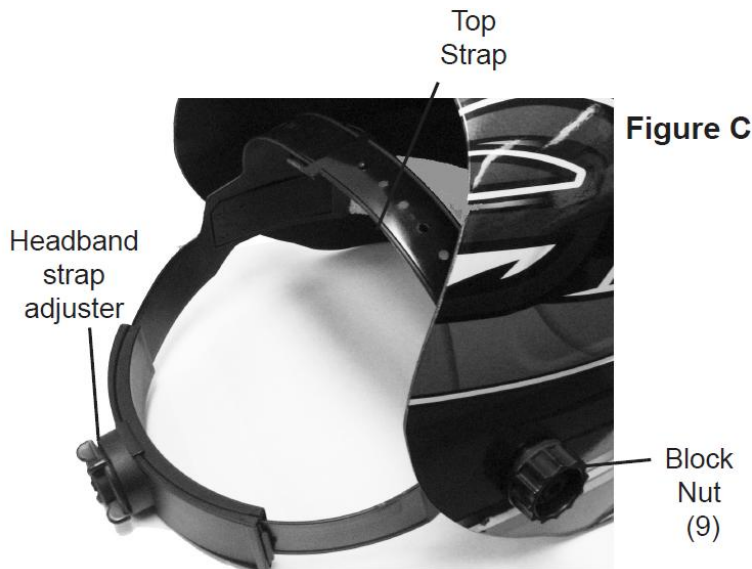

Solar Cells

This Welding Helmet utilizes high performance solar cells as power supply, and has two built-in 3V lithium batteries as power backup. No change of battery is needed. Under normal welding conditions, users can expect a battery lifetime of more than 5,000 hours.

Shades

User-selectable variable shades from 9 to 13 are adjusted at the turn of a shade knob (shade variable). This product is in full conformity with related DIN, ISO, EN379 safety standards and ANSI Z87.1-2003 standard.

Filters

The ultra high performance of UV and IR Auto-Darkening filters provides to user's eyes and face full protection against UV and IR radiation during entire welding process, even in clear state. The UV/ IR protection level is up to shade 16 at all times.

Time Delay and Sensitivity

At the moment the welding operation is started, the filter screen automatically changes from clear to dark.

The operator can vary the amount of time it takes the filter to return to a clear state and the sensitivity of the sensor using the controls inside the helmet.

The Sensitivity setting changes the amount of light needed to make the filter react.

Dark to Clear Adjustment Switch

Adjusts the speed the lens changes.

In FAST position: .25-.45 seconds

In SLOW position: .65-.80 seconds

Shade Number and Grinding Mode Selection

1. Irregular Darkening or Dimming

- a. Headband has been set unevenly on both sides of helmet (unequal distances from the eyes to filter's lens).
- b. Reset Headband to reduce difference in distances to filter, if necessary.

2. Auto-Darkening Filter Does Not Darken or Flickers

- a. Front Cover Lens is soiled or damaged (change the cover lens).
- b. Sensors are soiled (clean surface of the sensors).
- c. Welding current is too low (turn Dark to Clear Adjustment switch to the "SLOW" position, if necessary).

3. Slow Response

- a. Operating temperature is too low (do not use at temperatures below 23° F).

4. Poor Vision

- a. Front/Inside Cover Lens and/or filter soiled (change it).
- b. Insufficient ambient light.
- c. Shade number is incorrectly set (reset shade number).

5. Welding Helmet Slips

- a. Headband is not adjusted properly (must be lowered).

Stop using the Helmet immediately if any of the mentioned problems cannot be corrected.



This Product, when used for welding or cutting, produces fumes or gases which contain chemicals known to the State of California to cause birth defects and, in some cases, cancer. (California Health & Safety code Sec. 25249.5 et seq.)

NOTE

Considerations about welding and the effects of low frequency electric and magnetic fields



About Pacemakers:

Consult your doctor before operating a welding helmet if you have a pacemaker.

Maintenance and Servicing



Procedures not specifically explained in this manual must be performed only by a qualified technician.

WARNING

TO PREVENT SERIOUS INJURY FROM TOOL FAILURE:
Do not use damaged equipment. If abnormal noise or vibration occurs, have the problem corrected before further use.

Lens and Helmet Maintenance

Replace the Front Lens Cover if it is damaged (cracked, scratched, soiled or pitted).

1. To Replace the Cover:

- a. Remove the standard filter frame from the inside of the helmet by removing (4) screws with Phillips head screwdriver.
- b. Install magnifying lens from the bottom into the retaining brackets of new frame with flat side facing the auto-darkening lens.
- c. Install new frame inside helmet using (4) screws with Phillips head screwdriver.
- d. Leave lens in down position for magnification, or slide up to top position when not in use.

2. **Clean the Filter Lens** with a clean lint-free tissue or cotton cloth.

3. **Do not immerse** the lens in water or any other liquid. Do not use abrasives, solvents or oil based cleaners.

4. **Do not remove** the auto-darkening filter from the Auto-Darkening Welding Helmet. Do not try to open the filter.

5. **Storage temperature:** -4° to 158° F.

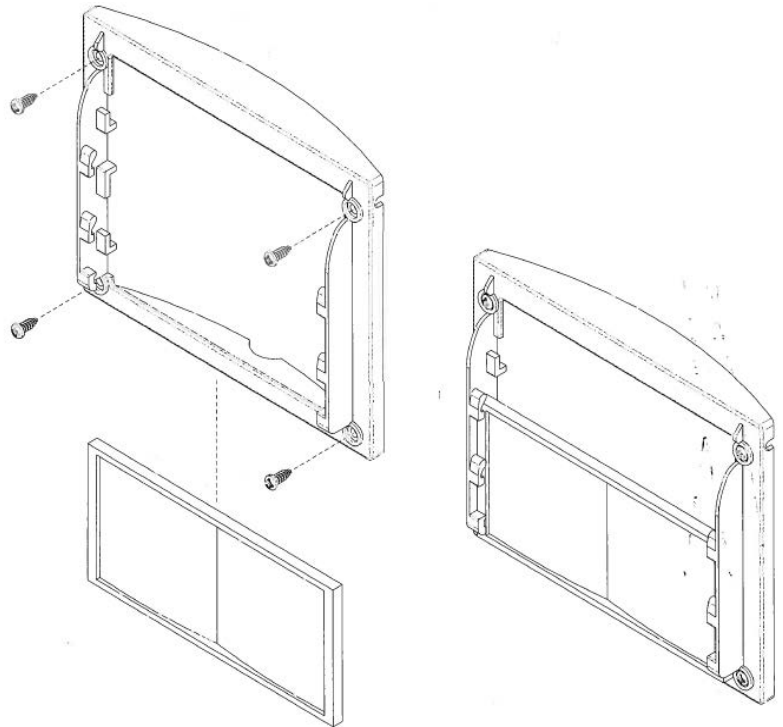

Parts List and Diagram

PLEASE READ THE FOLLOWING CAREFULLY

THE MANUFACTURER AND/OR DISTRIBUTOR HAS PROVIDED THE PARTS LIST AND ASSEMBLY DIAGRAM IN THIS MANUAL AS A REFERENCE TOOL ONLY. NEITHER THE MANUFACTURER NOR DISTRIBUTOR MAKES ANY REPRESENTATION OR WARRANTY OF ANY KIND TO THE BUYER THAT HE OR SHE IS QUALIFIED TO MAKE ANY REPAIRS TO THE PRODUCT, OR THAT HE OR SHE IS QUALIFIED TO REPLACE ANY PARTS OF THE PRODUCT. IN FACT, THE MANUFACTURER AND/OR DISTRIBUTOR EXPRESSLY STATES THAT ALL REPAIRS AND PARTS REPLACEMENTS SHOULD BE UNDERTAKEN BY CERTIFIED AND LICENSED TECHNICIANS, AND NOT BY THE BUYER. THE BUYER ASSUMES ALL RISK AND LIABILITY ARISING OUT OF HIS OR HER REPAIRS TO THE ORIGINAL PRODUCT OR REPLACEMENT PARTS THERETO, OR ARISING OUT OF HIS OR HER INSTALLATION OF REPLACEMENT PARTS THERETO.

Parts List

Part	Description	Qty
1	Helmet Body	1
2	Headgear	1
3	Headgear Adjusting Knob	1
4	Headgear Angle Adjusting Knob	1
5	Shade No. Adjusting	1

Part	Description	Qty
6	Protective Plate	1
7	Solar Panel	1
8	Fixed Plate	1
9	Press Spring	1
10	UV IR Filter	1

