

DIAPHRAGM HAND PUMPS

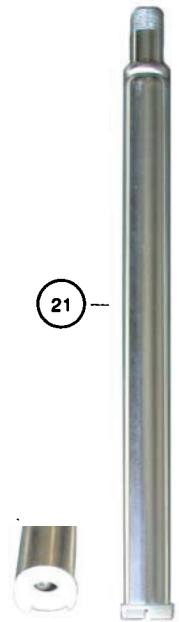
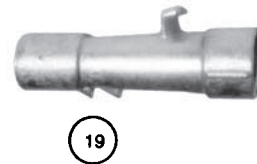
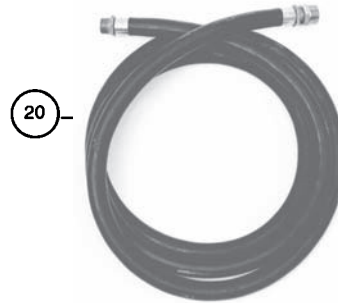
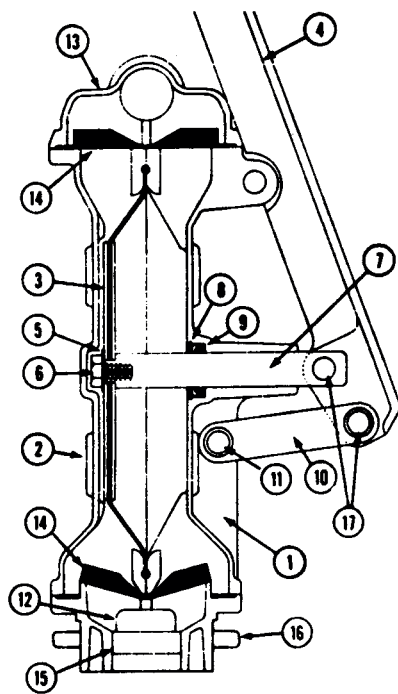

New
Foot valve

Ref	Part #	Description	No. Req	Ref	Part #	Description	No. Req.
1	L30-10N	Front Plate	1	15	L30-59N	Bottom Cover	1
2	L30-20N	Rear Plate	1	16	L30-79N	Bung Adapter	1
3	L30-30N	Diaphragm.	1	17	L30-39N	Handle Pin	2
4	L30-40N	Handle Assembly	1	18	L30-70N	Hex Head Bolts	16
5	L30-31N	Washer.	1	-	L30-71N	O.D. Spring	3
6	L30-32N	Bolt	1	19	L30-90N	Nozzle, Plain	1
7	L30-33N	Connecting Rod	1				
8	L30-34N	Packing Washer	1	20	L30-95N	8' Static wire Hose, 3/4 Male	1
9	L30-35N	Pressure Seal	1	21	L30-99N	Telescoping Suction Pipe Assy	1
10	L30-46N	Connecting Link	1	-	L30-97N	Suction Pipe "O" Ring	1
11	L30-45N	Link Pin	1		L302193	Repair Kit (3,9,14)	1
12	L30-61N	Pick Up Screen	1				
13	L30-50N	Upper Cover	1				
14	L30-52N	Rubber Reed Valve	2				

All specifications are approximate and subject to change without notice

NOTICE -

This pump is designed for use with non-corrosive petroleum based products of light to medium viscosity such as gasoline, fuel oil and motor oils. It should not be used with solvents, acids, alkalis, or other corrosive liquids. **GUARANTEE DOES NOT COVER ANY PUMP SHOWING EVIDENCE OF RUST OR OTHER CORROSION. Fuels containing Ethanol will cause more frequent replacement of rubber parts.**

Make sure the pump and all other equipment used or located in the pumping area are grounded. Do not use pump if any static sparking or electrical shock occurs. Stop pumping immediately and do not use.

Repair parts must be ordered by part number and name. When ordering, give the exact quantity of each part desired.