

# MSD IGNITION INSTALLATION INSTRUCTIONS

## Crimping with the MSD Mini-Stripper-Crimper PN 3503

<b>Tools Required:</b> Razor Blade	Vise (4" Minimum)	Needle Nose Pliers
------------------------------------	-------------------	--------------------

**Note:** MSD offers a dielectric grease called Spark Guard, PN 8804. A drop of this grease will ease installation of the boots. It also helps stop voltage leaks, prevents moisture build up and eases removal of the wire from its connection.

The Mini-Stripper-Crimper is an all in one spark plug wire stripper and crimp tool. It will work with both MSD 8.5mm Super Conductor and 8mm Heli-Core wires to produce a strong, professional crimp.

## TERMINALS

MSD offers several different terminals with our Universal wire sets. There are two terminal styles used, either a standard style or the Dual Crimp Terminal (Figure 1). The standard design requires stripping more of the wire sleeve because the conductor will be bent under the terminal. The Dual Crimp has specific crimp tabs for the conductor which require needle nose pliers.

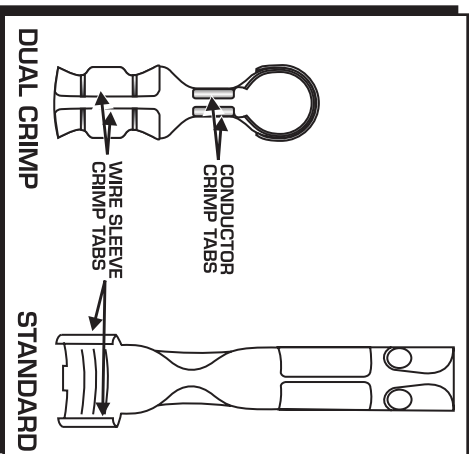

Figure 1 Identifying the Different Style Terminals.

## STRIPPING THE WIRE

1. Once you've determined which terminals you are working with, position the wire in the corresponding strip guide. There are two holes; one for the 8mm wire and another for the 8.5mm wire.
2. There are two stripping positions indicated on the stripping slot, depending on the terminal being used. Slide the wire to the correct position and strip the sleeve by holding a razor blade flush with the strip guide and rotate the wire 360° (Figure 2).
3. Remove the wire and twist the cut end of the sleeve off in a counterclockwise direction.

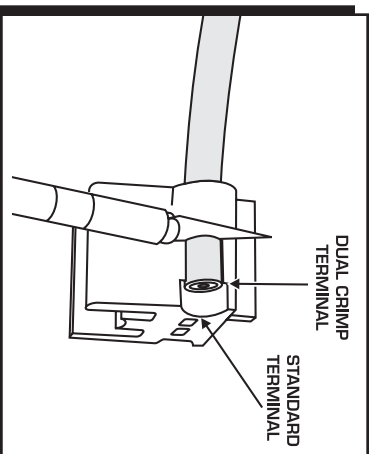

Figure 2 Stripping the Sleeve.

## Service

In case of malfunction, this MSD component will be repaired free of charge according to the terms of the warranty. When returning MSD components for warranty service, **Proof of Purchase** must be supplied for verification. After the warranty period has expired, repair service is based on a minimum and maximum fee.

**All returns must have a Return Material Authorization (RMA) number** issued to them before being returned. To obtain an RMA number please contact MSD Customer Service at 1 (888) MSD-7859 or visit our website at [www.msdisignition.com/rma](http://www.msdisignition.com/rma) to automatically obtain a number and shipping information.

When returning the unit for repair, leave all wires at the length in which you have them installed. Be sure to include a detailed account of any problems experienced, and what components and accessories are installed on the vehicle. The repaired unit will be returned as soon as possible using Ground shipping methods (ground shipping is covered by warranty). For more information, call MSD Ignition at (915) 855-7123. MSD technicians are available from 7:00 a.m. to 5:00 p.m. Monday - Friday (mountain time).

## Limited Warranty

MSD IGNITION warrants this product to be free from defects in material and workmanship under its intended normal use\*, when properly installed and purchased from an authorized MSD dealer, for a period of one year from the date of the original purchase. This warranty is void for any products purchased through auction websites. If found to be defective as mentioned above, it will be repaired or replaced at the option of MSD Ignition. Any item that is covered under this warranty will be returned free of charge using Ground shipping methods.

This shall constitute the sole remedy of the purchaser and the sole liability of MSD Ignition. To the extent permitted by law, the foregoing is exclusive and in lieu of all other warranties or representation whether expressed or implied, including any implied warranty of merchantability or fitness. In no event shall MSD Ignition or its suppliers be liable for special or consequential damages.

\*Intended normal use means that this item is being used as was originally intended and for the original application as sold by MSD Ignition. Any modifications to this item or if it is used on an application other than what MSD Ignition markets the product, the warranty will be void. It is the sole responsibility of the customer to determine that this item will work for the application they are intending. MSD Ignition will accept no liability for custom applications.

## CRIMPING

To achieve the strongest crimp possible, it is required to bend the crimp tabs over about 90° using needle nose pliers (Figure 3). Follow the instructions for the terminal you are using.

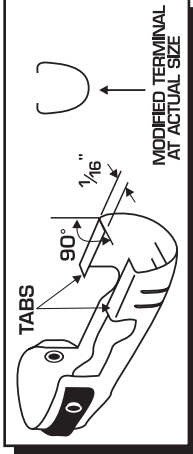

Figure 3 Preparing the Terminals.

## STANDARD TERMINALS

1. After stripping the sleeve, fold the conductor back along the wire insulation (Figure 4).
2. Do not allow the conductor to pull tightly against the insulation. A small gap around the conductor should be present before crimping. Slide the wire into the terminal with the conductor positioned so it is in contact with the bottom of the terminal. Position the wire through until the insulation protrudes about 1/8" beyond the crimp tabs.
3. Position the wire and terminal into the "W" groove of the Mini-Stripper-Crimper and proceed to Step 4.

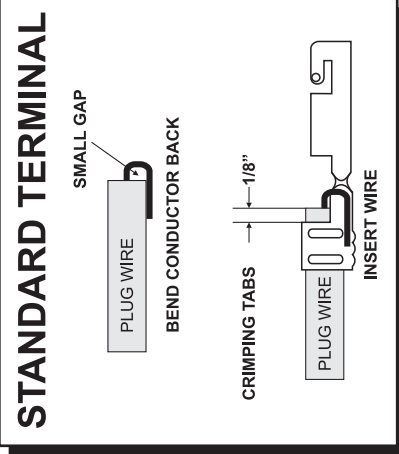

Figure 4 Positioning the Wire in the Terminal.

## DUAL CRIMP TERMINALS

1. After stripping the sleeve, position the wire in the terminal so the insulation protrudes about 1/8" beyond the insulation crimp tabs and the conductor extends about 1/8" past the conductor crimp tabs (Figure 5).
  2. Position the wire and terminal into the "W" groove of the Mini-Stripper Crimper and follow Steps 4 - 6 to crimp the terminal to the sleeve.
- Note:** It is normal for the conductor to retract into the insulation slightly as the sleeve crimp is made.
3. After the sleeve is crimped, push the conductor between the crimp tabs and use a set of needle nose pliers to crimp them together. **DO NOT OVER CRIMP.**

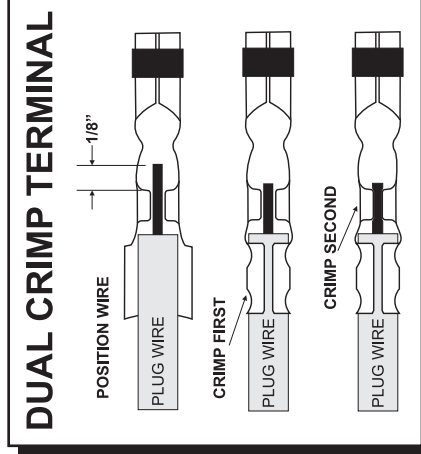

Figure 5 Crimping a Dual Crimp Terminal.

4. Slide the other part of the Mini-Stripper-Crimper over the wire terminal and lightly press them together (Figure 6).
5. Put the assembly into a vise making sure the alignment tabs are on the outside edge of the vise jaws (Figure 7).
6. Slowly close the vise making sure the tool and terminal stay properly positioned and aligned (Figure 8). Stop applying pressure when the terminal ends have wrapped securely around the sleeve and grip the wire.

**Note:** DO NOT OVER CRIMP! It is possible to tear the sleeve of the wire by excessive pressure on the vise. This will cause a weaker crimp.

7. Back off the vise and remove the wire from the Crimper. Gently tug the terminal and inspect the position of the conductor to make sure the crimp is solid and firm.

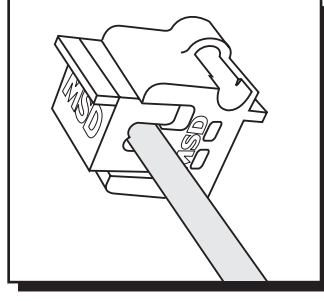

Figure 6 Aligning the Terminal in Tool.

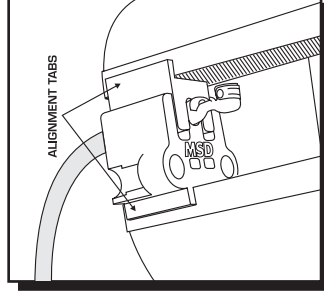

Figure 7 Preparing to Crimp in the Vise.

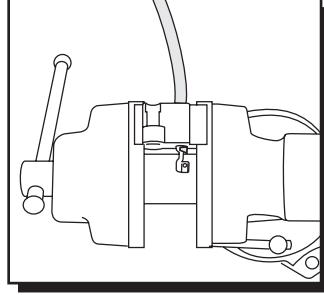

Figure 8 Crimping with the Vise.

## INSTALLING THE BOOT

To ease installation of the boots, use a drop of a dielectric grease such as MSD's Spark Guard, PN 8804. If you are installing the brass 90° socket style terminals, slide the terminal all the way through the boot, then grip the terminal near the wire crimp and bend it over 90° and slide the boot down (Figure 9).

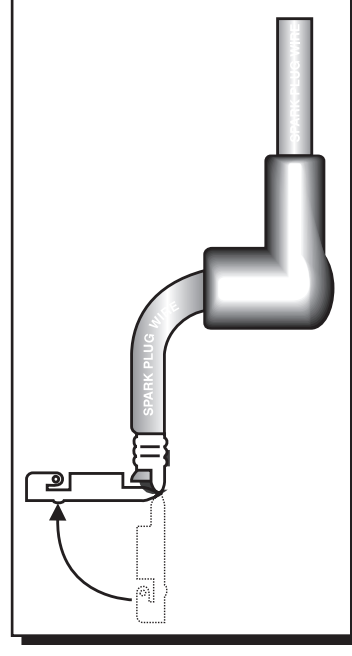

Figure 9 Installing the Boots.

If you build a lot of custom spark plug wire sets, MSD offers a professional tool, the Pro-Crimp Tool, PN 3505.