

## Lever-Type Dial Indicators DIAL TEST INDICATORS

SMALL TOOL INSTRUMENTS  
AND DATA MANAGEMENT



# Enhanced Durability, Sensitivity and Readability



## Inspection

- The QR code is used by the factory to accurately match the inspection certificate to the test indicator.



## Stylus length is marked on the dial face

- Stylus length is marked on the dial face to assist customers when ordering replacement styli.



## Attachable limit hands

- Limit hands (optional) can be attached to the bezel, allowing easy identification of the upper and lower limits of tolerance.

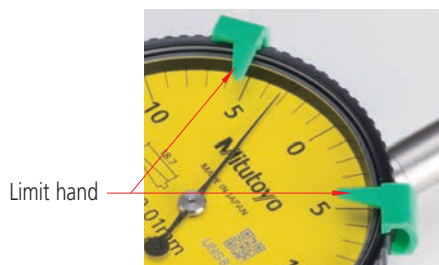

## ø8/ø9.52 stem to fit dovetails is a standard accessory

- A ø8mm (ø0.315 in) plain stem (**21CAB104**) for the Metric models or a ø9.52mm (ø3/8 in) plain stem (**21CAB105**) for the Inch models that attaches to any dovetail on the frame is supplied as a standard accessory. Other sizes are available as optional accessories:

ø4mm (ø0.157 in) stem: **21CAB106**

ø6mm (ø0.236 in) stem: **21CAB103**

certificate provided

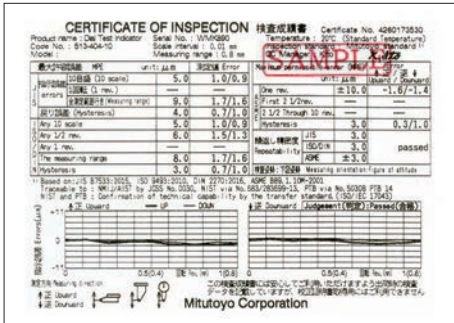

Extended stylus length for 0.001mm, 0.002mm, and 0.0001" graduation models

- Longer styli for the most sensitive indicators allow access to difficult-to-measure features.

0.001mm graduation models: L<sub>2</sub> now 15.2mm, was 11.2mm  
 0.002mm graduation models: L<sub>2</sub> now 11.2mm, was 9.4mm  
 0.0001 in graduation models: L<sub>2</sub> now 0.61 in, was 0.45 in

Ruby ball-tipped stylus added

- A ruby tip has wear-resistance several times greater than a carbide tip and, since it is nonconductive, it can be used safely on an electrical discharge machine.

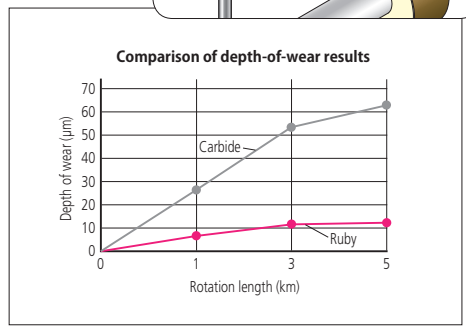
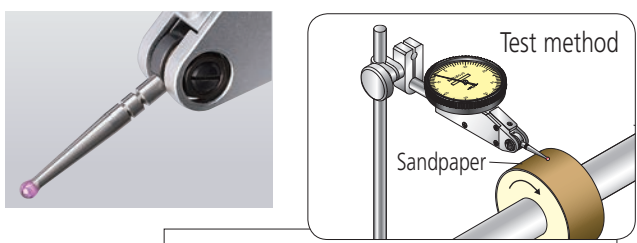

# Enhanced Durability, Sensitivity and Readability



## Improved readability

- Using universal fonts, changing dial face color and reviewing the relationship between pointer and scale marks have drastically improved readability.

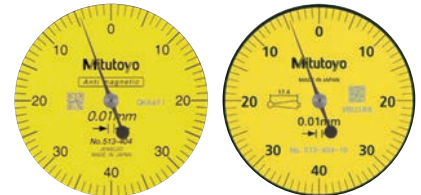

Conventional

New

## Crystal for readability

- Glare-free flat crystal face allows easy reading of graduations.



Conventional

New

## Prevents dust and oil from penetrating the dial face

- The O-ring seal on the bezel provides smooth rotation and prevents dust and oil from penetrating the dial face.

## Bonded bezel and crystal

- Bonding the bezel and crystal eliminates a gap for cutting fluid or oil to penetrate the dial face.

## Prevents bezel detachment

- A flange prevents the bezel from unintentionally being removed during handling.

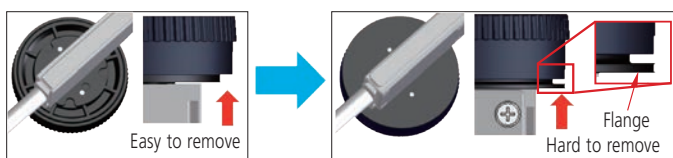

Conventional

New

## Parts

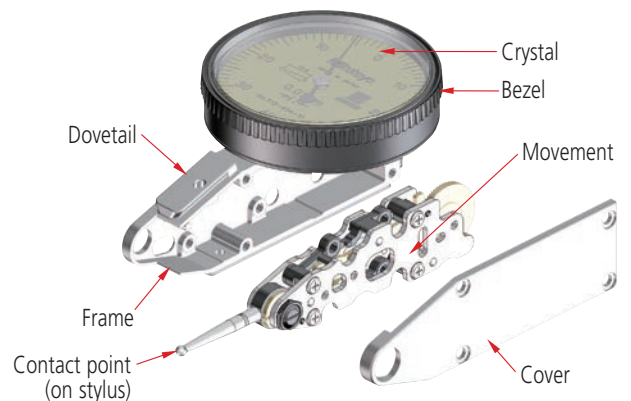

## Choice of dial position

Four models are available, each with a different orientation of the dial to allow the best visibility in any situation.

- Horizontal (standard model) - dial is on top of the frame.
- Vertical: dial is on the end of the frame.
- Horizontal (20° tilted face): dial is on top of the frame but tilted 20°.
- Parallel: dial is on the side of the frame.



## Multi-layer coatings on the crystal

- Hard, antifouling and non-glare coatings on the crystal inhibit scratches, contamination and glare on the surface.

## Improved stylus bearing

- The conventional method of mounting the stylus pivot bearing screw in the frame is prone to loosen with prolonged use. A unique sub-plate structure has been incorporated in all models to eliminate this issue.

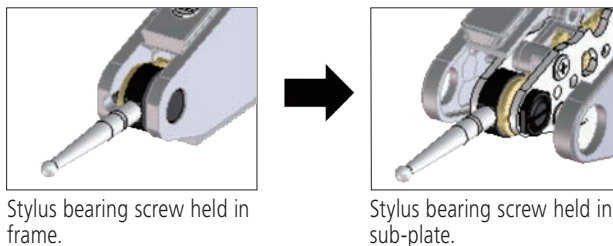

## Maintain trackability

- The ability of the indicator to track small changes in displacement deteriorates with prolonged use due to minute changes in clearance between the gears. Redesigned mounting for the gears enables the ability to maintain good trackability.

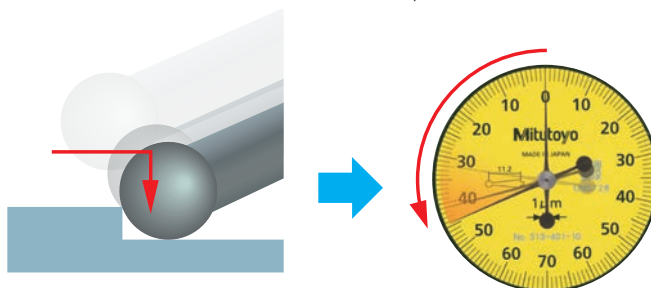

Indicator trackability depends on maintaining gear-train stability



# Horizontal (Standard model)

**Metric** Wide variations of models conform to the required accuracy, range and surface of workpieces.



513-424-10

Contact point No. 137557



Graduation: 0.01mm  
Range: 0.5mm

513-424-10E/513-424-10A/  
513-424-10T

- Standard
- Double scale spacing
- Carbide contact point (Anti-magnet)



513-414-10

Contact point No. 131324



Graduation: 0.01mm  
Range: 0.5mm

513-414-10E/513-414-10A/  
513-414-10T

- Long stylus
- Carbide contact point (Anti-magnet)
- Double scale spacing



513-478-10

Contact point No. 21CZA210

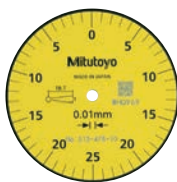

Graduation: 0.01mm  
Range: 0.5mm

513-478-10E

- Ruby contact point (non-magnet)
- Standard
- Double scale spacing



513-474-10

Contact point No. 21CZA201



Graduation: 0.01mm  
Range: 0.8mm

513-474-10E

- Ruby contact point (non-magnet)
- Standard



513-466-10

Contact point No. 137557



Graduation: 0.01mm  
Range: 0.5mm

513-466-10E

- Small face diameter
- Double scale spacing
- Compact
- Carbide contact point (Anti-magnet)



513-464-10

Contact point No. 103006



Graduation: 0.01mm  
Range: 0.8mm

513-464-10E

- Small face diameter
- Compact
- Carbide contact point (Anti-magnet)



513-404-10

Contact point No. 103006



Graduation: 0.01mm  
Range: 0.8mm

513-404-10E/513-404-10A/  
513-404-10T/513-404-10C

- Standard
- Carbide contact point (Anti-magnet)



513-415-10

Contact point No. 136013



Graduation: 0.01mm  
Range: 1.0mm

513-415-10E/513-415-10A/  
513-415-10T

- Long stylus
- Carbide contact point (Anti-magnet)



513-477-10

Contact point No. 21CZA211



Graduation: 0.01mm  
Range: 1.0mm

513-477-10E

- Ruby contact point (non-magnet)
- Long stylus



513-475-10

Contact point No. 21CZB068

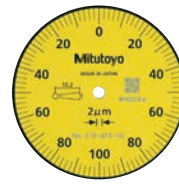

Graduation: 0.002mm  
Range: 0.2mm

513-475-10E

- Ruby contact point (non-magnet)
- Standard



513-426-10

Contact point No. 137557



Graduation: 0.01mm  
Range: 1.5mm

513-426-10E/513-426-10A

- With revolution counter
- Double scale spacing
- Carbide contact point (Anti-magnet)



513-425-10

Contact point No. 103011

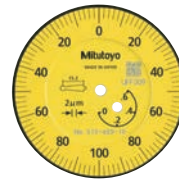

Graduation: 0.002mm  
Range: 0.6mm

513-425-10E/513-425-10A

- With revolution counter
- Carbide contact point (Anti-magnet)



513-405-10

Contact point No. 103011

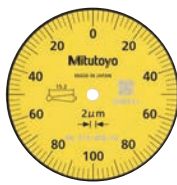

Graduation: 0.002mm  
Range: 0.2mm

513-405-10E/513-405-10A/  
513-405-10T

- Standard
- Carbide contact point (Anti-magnet)



513-465-10

Contact point No. 103011

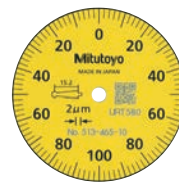

Graduation: 0.002mm  
Range: 0.2mm

513-465-10E

- Small face diameter
- Compact
- Carbide contact point (Anti-magnet)



513-471-10

Contact point No. 21CZA209

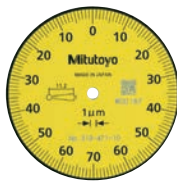

Graduation: 0.001mm  
Range: 0.14mm

513-471-10E

- Ruby contact point (non-magnet)
- High accuracy



513-401-10

Contact point No. 103010

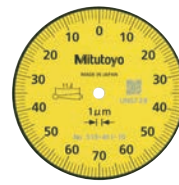

Graduation: 0.001mm  
Range: 0.14mm

513-401-10E

- High accuracy
- Carbide contact point (Anti-magnet)



# Horizontal (Standard model)

Inch



513-402-10

Contact point No. 133195



Graduation: 0.0005 in  
Range: 0.03 in

513-402-10E/513-402-10T

- Standard
- Carbide contact point (Anti-magnet)



513-462-10

Contact point No. 133195



Graduation: 0.0005 in  
Range: 0.03 in

513-462-10E

- Compact
- Carbide contact point (Anti-magnet)



513-472-10

Contact point No. 21CZA204



Graduation: 0.0005 in  
Range: 0.03 in

513-472-10E

- Standard
- Ruby contact point (non-magnet)



513-403-10

Contact point No. 21CZB064



Graduation: 0.0001 in  
Range: 0.008 in

513-403-10E/513-403-10T

- Standard
- Anti-magnet (non-magnet)



513-412-10

Contact point No. 136290



Graduation: 0.0005 in  
Range: 0.03 in

513-412-10E/513-412-10T

- Long stylus
- Carbide contact point (Anti-magnet)



513-473-10

Contact point No. 21CZB112



Graduation: 0.0001 in  
Range: 0.008 in

513-473-10E

- Standard
- Ruby contact point (non-magnet)



512-479-10

Contact point No. 21CZA214



Graduation: 0.0005 in  
Range: 0.03 in

512-479-10E

- Long stylus
- Ruby contact point (non-magnet)



513-463-10

Contact point No. 21CZB064



Graduation: 0.0001 in  
Range: 0.008 in

513-463-10E

- Compact
- Carbide contact point (Anti-magnet)

Metric/Inch



513-409-10

Contact point No. 103011



Graduation: 0.002mm/0.0001 in  
Range: 0.2mm/0.0076 in

513-409-10E/513-409-10T

Carbide contact point (Anti-magnet)

Inch/Metric



513-406-10

Contact point No. 133195

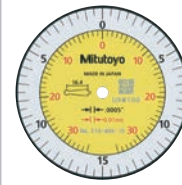

Graduation: 0.0005 in/0.01mm  
Range: 0.03 in/0.7mm

513-406-10E/513-406-10T

Carbide contact point (Anti-magnet)

DIMENSIONS

Vertical

Unit: mm

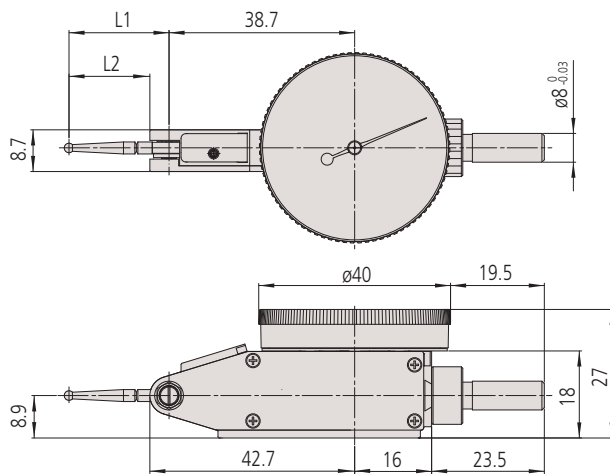

Compact

Unit: mm

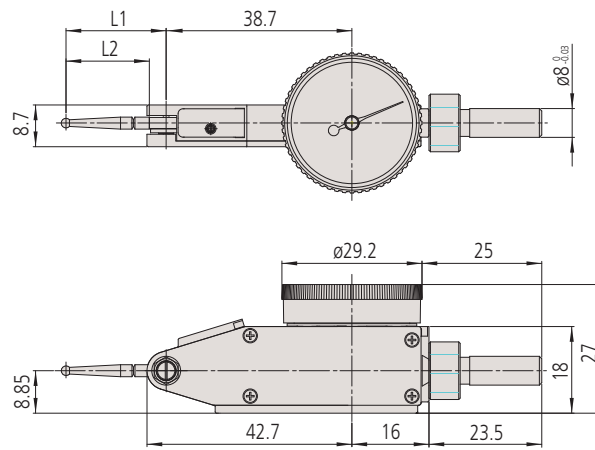

Type	Order No.	L1	L2
Vertical	513-401-10E	14.7	11.2
	513-471-10E		
	513-405-10E/A/T		
	513-415-10E/A	18.7	15.2
	513-475-10E		
	513-404-10E/A/T		
	513-474-10E	20.9	17.4
	513-424-10E/A/T		
	513-426-10E/A		
	513-478-10E	22.2	18.7
	513-414-10E/A/T		
	513-415-10E/A/T		
513-477-10E	44.5	41.0	

Type	Order No.	L1	L2
Compact	513-465-10E	18.7	15.2
	513-464-10E	20.9	17.4
	513-466-10E	22.2	18.7



# Horizontal (Standard model)

## SPECIFICATIONS

### Metric

Order No.			Graduation	Range	Dial reading	Indication accuracy				Mass	Measuring force	High accuracy	With revolution counter	Long stylus	Standard	Double scale spacing	Compact	Carbide contact point (Anti-magnet)	Ruby contact point (non-magnet)	
Basic set	Plus set	Full set				Measuring range	10 scale divisions	Hysteresis	Repeatability											
513-424-10E	513-424-10A	513-424-10T	0.01 mm	0.5 mm	0-25-0	6 μm	5 μm	4 μm	3 μm	45g	0.3N or less									
513-478-10E	-	-				6 μm		4 μm												
513-466-10E	-	-		0.8 mm	0-40-0	9 μm	5 μm	4 μm	45g	0.3N or less										
513-404-10E	513-404-10A	513-404-10T				9 μm		4 μm												
513-414-10E	513-414-10A	513-414-10T		0.5 mm	0-25-0	10 μm	5 μm	5 μm	45g	0.2N or less										
513-474-10E	-	-		0.8 mm	0-40-0	9 μm		4 μm												
513-464-10E	-	-		1.0 mm	0-50-0	10 μm	5 μm	5 μm	41g	0.3N or less										
513-415-10E	513-415-10A	513-415-10T				10 μm		5 μm												
513-477-10E	-	-		1.5 mm	0-25-0	16 μm	2 μm	3 μm	45g	0.2N or less										
513-426-10E	513-426-10A	-				16 μm		3 μm												
543-405-10E	543-405-10A	543-405-10T	0.002 mm	0.2 mm	0-100-0	4 μm	2 μm	3 μm	45g	0.3N or less										
513-471-10E	-	-	0.001 mm	0.14 mm	0-70-0															4 μm
513-475-10E	-	-	0.002 mm	0.6 mm	0-100-0	7 μm	2 μm	4 μm	41g	0.4N or less										
513-425-10E	513-425-10A	-				7 μm														4 μm
513-465-10E	-	-	0.001 mm	0.14 mm	0-70-0	4 μm	3 μm	3 μm	45g	0.3N or less										
513-401-10E	-	-																		4 μm

### Inch

Order No.			Graduation	Range	Dial reading	Indication accuracy			Mass	Measuring force	High accuracy	With revolution counter	Long stylus	Standard	Double scale spacing	Compact	Carbide contact point (Anti-magnet)	Ruby contact point (non-magnet)
Basic set	Plus set	Full set				One rev.	Hysteresis	Repeatability										
513-402-10E	-	513-402-10T	0.0005 in	0.03 in	0-15-0	±0.0005 in	0.0002 in	0.0002 in	45g	0.3N or less								
513-472-10E	-	-																
513-412-10E	-	513-412-10T																
513-479-10E	-	-																
513-462-10E	-	-	0.0001 in	0.008 in	0-4-0	±0.0001 in	0.0001 in	0.00004 in	41g	0.2N or less								
513-403-10E	-	513-403-10T																
513-473-10E	-	-																
513-463-10E	-	-	41g	0.3N or less														

### Metric/Inch

Order No.			Graduation	Range	Dial reading	Indication accuracy				Mass	Measuring force	High accuracy	With revolution counter	Long stylus	Standard	Double scale spacing	Compact	Carbide contact point (Anti-magnet)	Ruby contact point (non-magnet)
Basic set	Plus set	Full set				Measuring range	10 scale divisions	Hysteresis	Repeatability										
513-409-10E	-	513-409-10T	0.002mm / 0.0001 in	0.2mm / 0.0076 in	0-10-0 / 0-38-0	4μm	2μm	3μm	1μm	45g	0.3N or less								

### Inch/Metric

Order No.			Graduation	Range	Dial reading	Indication accuracy			Mass	Measuring force	High accuracy	With revolution counter	Long stylus	Standard	Double scale spacing	Compact	Carbide contact point (Anti-magnet)	Ruby contact point (non-magnet)
Basic set	Plus set	Full set				Measuring range	Hysteresis	Repeatability										
513-406-10E	-	513-406-10T	0.0005 in / 0.01mm	0.03 in / 0.7mm	0-15-0 / 0-35-0	±0.0005 in	0.0002 in	0.0002 in	45g	0.3N or less								

\* Stem with ø6 dovetail groove is not included in the mass.

\* Be sure to perform calibration with reference gage, etc. after changing the contact point. The inside parts may be damaged when the contact point is changed due to the breakage. In the case the of the significant deterioration during the operation, repair is required.



**Parallel** (The scale can be read from the front, with the contact point pivoting in a plane parallel to that of the dial face.)

<p><b>Metric</b></p> <p><b>513-484-10</b> Contact point No. 103006</p>	<p>Graduation: 0.01mm Range: 0.8mm</p> <p><b>513-484-10E/513-484-10A/ 513-484-10T</b></p> <p> Carbide contact point (Anti-magnet)</p>	<p><b>513-485-10</b> Contact point No. 103011</p>	<p>Graduation: 0.002mm Range: 0.2mm</p> <p><b>513-485-10E</b></p> <p> Carbide contact point (Anti-magnet)</p>
<p><b>513-486-10</b> Contact point No. 137557</p>	<p>Graduation: 0.01mm Range: 0.5mm</p> <p><b>513-486-10E</b></p> <p> Double scale spacing  Carbide contact point (Anti-magnet)</p>	<p><b>Inch</b></p> <p><b>513-482-10</b> Contact point No. 133195</p>	<p>Graduation: 0.0005 in Range: 0.03 in</p> <p><b>513-482-10A/513-482-10T</b></p> <p> Carbide contact point (Anti-magnet)</p>

**SPECIFICATIONS**

Order No.			Graduation	Range	Dial reading	Indication accuracy				Mass	Measuring force	High accuracy	With revolution counter	Long stylus	Standard	Double scale spacing	Compact	Carbide contact point (Anti-magnet)	Ruby contact point (non-magnet)	
Basic set	Plus set	Full set				Measuring range	10 scale divisions	Hysteresis	Repeatability											
<b>513-484-10E</b>	<b>513-484-10A</b>	<b>513-484-10T</b>	0.01mm	0.8mm	0-40-0	9μm	5μm	4μm	3μm	53g	0.3N or less	<input checked="" type="checkbox"/>	<input checked="" type="checkbox"/>	<input checked="" type="checkbox"/>	<input checked="" type="checkbox"/>	<input checked="" type="checkbox"/>	<input checked="" type="checkbox"/>	<input checked="" type="checkbox"/>	<input checked="" type="checkbox"/>	
<b>513-485-10E</b>	-	-	0.002mm	0.2mm	0-100-0	4μm	2μm	3μm	1μm			<input type="checkbox"/>	<input type="checkbox"/>	<input type="checkbox"/>	<input type="checkbox"/>	<input type="checkbox"/>	<input type="checkbox"/>	<input type="checkbox"/>	<input checked="" type="checkbox"/>	<input type="checkbox"/>
<b>513-486-10E</b>	-	-	0.01mm	0.5mm	0-25-0	6μm	5μm	4μm	3μm			<input type="checkbox"/>	<input type="checkbox"/>	<input type="checkbox"/>	<input checked="" type="checkbox"/>	<input type="checkbox"/>	<input type="checkbox"/>	<input checked="" type="checkbox"/>	<input type="checkbox"/>	<input type="checkbox"/>

Order No.			Graduation	Range	Dial reading	Indication accuracy			Mass	Measuring force	High accuracy	With revolution counter	Long stylus	Standard	Double scale spacing	Compact	Carbide contact point (Anti-magnet)	Ruby contact point (non-magnet)
Basic set	Plus set	Full set				Measuring range	Hysteresis	Repeatability										
-	<b>513-482-10A</b>	<b>513-482-10T</b>	0.0005 in	0.03 in	0-15-0	±0.0005 in	0.0002 in	0.0002 in	53g	0.3N or less	<input checked="" type="checkbox"/>	<input checked="" type="checkbox"/>	<input checked="" type="checkbox"/>	<input checked="" type="checkbox"/>	<input checked="" type="checkbox"/>	<input checked="" type="checkbox"/>	<input checked="" type="checkbox"/>	<input type="checkbox"/>

\* Stem with ø6 dovetail groove is not included in the mass.  
 \* Be sure to perform calibration with reference gage, etc. after changing the contact point. The inside parts may be damaged when the contact point is changed due to the breakage. In the case the of the significant deterioration during the operation, repair is required.

**DIMENSIONS**

\* No dovetail in the back.

Unit: mm

Order No.	L1	L2
<b>513-484-10E</b>	20.9	17.4
<b>513-485-10E</b>	18.7	15.2
<b>513-486-10E</b>	22.2	18.7



# Vertical (Best suited for centering holes under the spindle of a machine tool.)

## Metric



513-454-10

Contact point No. 103006



Graduation: 0.01mm  
Range: 0.8mm

513-454-10E/513-454-10A/  
513-454-10T

Carbide contact point (Anti-magnet)

## Inch



513-452-10

Contact point No. 133195



Graduation: 0.0005 in  
Range: 0.03 in

513-452-10E/513-452-10T

Carbide contact point (Anti-magnet)



513-455-10

Contact point No. 103011



Graduation: 0.002mm  
Range: 0.2mm

513-455-10E/513-455-10A/  
513-455-10T

Carbide contact point (Anti-magnet)



513-453-10

Contact point No. 21CZB064



Graduation: 0.0001 in  
Range: 0.008 in

513-453-10E/513-453-10T

Carbide contact point (Anti-magnet)



513-456-10

Contact point No. 137557



Graduation: 0.01mm  
Range: 0.5mm

513-456-10E

Double scale spacing  
Carbide contact point (Anti-magnet)

## SPECIFICATIONS

### Metric

Order No.			Graduation	Range	Dial reading	Indication accuracy				Mass	Measuring force	High accuracy	With revolution counter	Long stylus	Standard	Double scale spacing	Compact	Carbide contact point (Anti-magnet)	Ruby contact point (non-magnet)
Basic set	Plus set	Full set				Measuring range	10 scale divisions	Hysteresis	Repeatability										
513-454-10E	513-454-10A	513-454-10T	0.01mm	0.8mm	0-40-0	9μm	5μm	4μm	3μm	46g	0.3N or less	<input checked="" type="checkbox"/>	<input checked="" type="checkbox"/>	<input checked="" type="checkbox"/>	<input checked="" type="checkbox"/>	<input checked="" type="checkbox"/>	<input checked="" type="checkbox"/>	<input checked="" type="checkbox"/>	
513-455-10E	513-455-10A	513-455-10T	0.002mm	0.2mm	0-100-0	4μm	2μm	3μm	1μm			<input type="checkbox"/>	<input type="checkbox"/>	<input type="checkbox"/>	<input type="checkbox"/>	<input type="checkbox"/>	<input type="checkbox"/>	<input type="checkbox"/>	<input type="checkbox"/>
513-456-10E	-	-	0.01mm	0.5mm	0-25-0	6μm	5μm	4μm	3μm			<input type="checkbox"/>	<input type="checkbox"/>	<input type="checkbox"/>	<input checked="" type="checkbox"/>	<input type="checkbox"/>	<input type="checkbox"/>	<input type="checkbox"/>	<input type="checkbox"/>

### Inch

Order No.			Graduation	Range	Dial reading	Indication accuracy			Mass	Measuring force	High accuracy	With revolution counter	Long stylus	Standard	Double scale spacing	Compact	Carbide contact point (Anti-magnet)	Ruby contact point (non-magnet)
Basic set	Plus set	Full set				Measuring range	Hysteresis	Repeatability										
513-452-10E	-	513-452-10T	0.0005 in	0.03 in	0-15-0	±0.0005 in	0.0002 in	0.0002 in	46g	0.3N or less	<input type="checkbox"/>	<input checked="" type="checkbox"/>	<input checked="" type="checkbox"/>	<input checked="" type="checkbox"/>	<input checked="" type="checkbox"/>	<input checked="" type="checkbox"/>	<input checked="" type="checkbox"/>	
513-453-10E	-	513-453-10T	0.0001 in	0.008 in	0-4-0	±0.0001 in	0.0001 in	0.00004 in			<input type="checkbox"/>	<input type="checkbox"/>	<input type="checkbox"/>	<input type="checkbox"/>	<input type="checkbox"/>	<input type="checkbox"/>	<input type="checkbox"/>	<input type="checkbox"/>

\* Stem with ø6 dovetail groove is not included in the mass.

\* Be sure to perform calibration with reference gage, etc. after changing the contact point. The inside parts may be damaged when the contact point is changed due to the breakage. In the case the of the significant deterioration during the operation, repair is required.

## DIMENSIONS

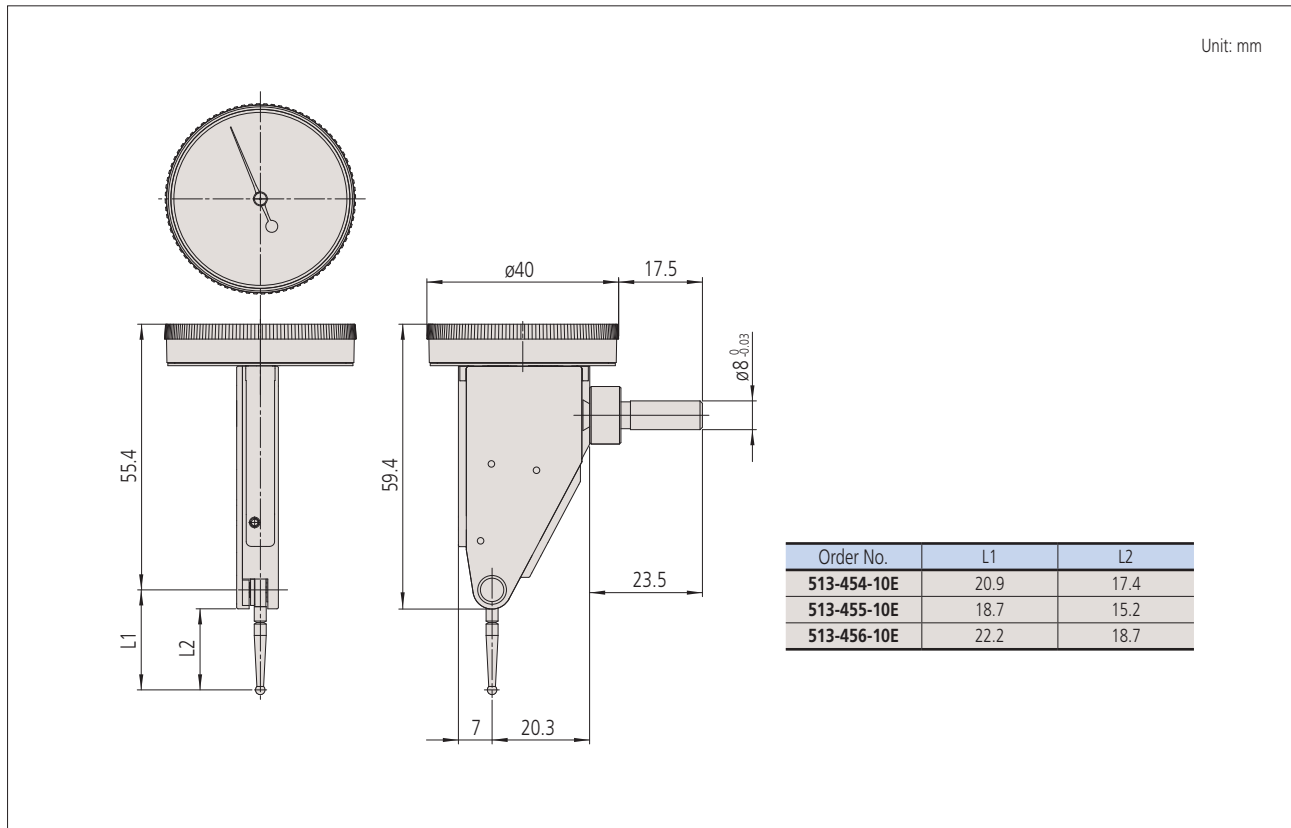



# Horizontal (20° Tilted Face) (Dial face inclined 20°, compared with the vertical type.)

## Metric



513-444-10

Contact point No. 103006

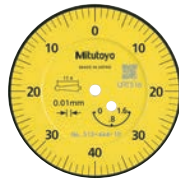

Graduation: 0.01mm  
Range: 1.6mm

513-444-10E/513-444-10A/  
513-444-10T

- With revolution counter
- Carbide contact point (Anti-magnet)



513-445-10

Contact point No. 103011



Graduation: 0.02mm  
Range: 0.4mm

513-445-10E/513-445-10A/  
513-445-10T

- With revolution counter
- Carbide contact point (Anti-magnet)

## Inch



513-442-10

Contact point No. 133195



Graduation: 0.0005 in  
Range: 0.06 in

513-442-10A/513-442-10T

- With revolution counter
- Carbide contact point (Anti-magnet)



513-442-16

Contact point No. 133195



Graduation: 0.0005 in  
Range: 0.06 in

513-442-16A/513-442-16T

- With revolution counter
- Carbide contact point (Anti-magnet)



513-446-10

Contact point No. 136290



Graduation: 0.0005 in  
Range: 0.06 in

513-446-10A/513-446-10T

- With revolution counter
- Long stylus
- Carbide contact point (Anti-magnet)



513-446-16

Contact point No. 136290



Graduation: 0.0005 in  
Range: 0.06 in

513-446-16A/513-446-16T

- With revolution counter
- Long stylus
- Carbide contact point (Anti-magnet)



513-443-10

Contact point No. 21CZB064



Graduation: 0.0001 in  
Range: 0.016 in

513-443-10A/513-443-10T

- With revolution counter
- Carbide contact point (Anti-magnet)



513-443-16

Contact point No. 21CZB064



Graduation: 0.0001 in  
Range: 0.016 in

513-443-16A/513-443-16T

- With revolution counter
- Carbide contact point (Anti-magnet)

SPECIFICATIONS

Metric

Order No.			Graduation	Range	Dial reading	Indication accuracy				Mass	Measuring force	High accuracy	With revolution counter	Long stylus	Standard	Double scale spacing	Compact	Carbide contact point (Anti-magnet)	Ruby contact point (non-magnet)
Basic set	Plus set	Full set				Measuring range	10 scale divisions	Hysteresis	Repeatability										
513-444-10E	513-444-10A	513-444-10T	0.01mm	1.6mm	0-40-0	16µm	5µm	5µm	3µm	48g	0.3N or less	<input checked="" type="checkbox"/>	<input checked="" type="checkbox"/>	<input type="checkbox"/>	<input checked="" type="checkbox"/>	<input type="checkbox"/>	<input checked="" type="checkbox"/>	<input checked="" type="checkbox"/>	<input type="checkbox"/>
513-445-10E	513-445-10A	513-445-10T	0.002mm	0.4mm	0-100-0	6µm	2µm	4µm	1µm			<input type="checkbox"/>	<input type="checkbox"/>	<input type="checkbox"/>	<input type="checkbox"/>	<input type="checkbox"/>	<input type="checkbox"/>	<input type="checkbox"/>	<input checked="" type="checkbox"/>

Inch

Order No.			Graduation	Range	Dial reading	Indication accuracy			Mass	Measuring force	High accuracy	With revolution counter	Long stylus	Standard	Double scale spacing	Compact	Carbide contact point (Anti-magnet)	Ruby contact point (non-magnet)
Basic set	Plus set	Full set				Measuring range	Hysteresis	Repeatability										
-	513-442-10A	513-442-10T	0.0005 in	0.06 in	0-15-0	±0.0005 in	0.0002 in	0.0002 in	48g	0.3N or less	<input checked="" type="checkbox"/>	<input checked="" type="checkbox"/>	<input type="checkbox"/>	<input checked="" type="checkbox"/>	<input type="checkbox"/>	<input type="checkbox"/>	<input checked="" type="checkbox"/>	<input type="checkbox"/>
-	513-442-16A	513-442-16T									<input type="checkbox"/>	<input type="checkbox"/>	<input type="checkbox"/>	<input checked="" type="checkbox"/>	<input checked="" type="checkbox"/>	<input checked="" type="checkbox"/>	<input checked="" type="checkbox"/>	
-	513-446-10A	513-446-10T									<input checked="" type="checkbox"/>	<input checked="" type="checkbox"/>	<input type="checkbox"/>	<input checked="" type="checkbox"/>	<input checked="" type="checkbox"/>	<input checked="" type="checkbox"/>	<input checked="" type="checkbox"/>	
-	513-446-16A	513-446-16T									<input checked="" type="checkbox"/>	<input checked="" type="checkbox"/>	<input type="checkbox"/>	<input checked="" type="checkbox"/>	<input checked="" type="checkbox"/>	<input checked="" type="checkbox"/>	<input checked="" type="checkbox"/>	
-	513-443-10A	513-443-10T									<input checked="" type="checkbox"/>	<input checked="" type="checkbox"/>	<input type="checkbox"/>	<input checked="" type="checkbox"/>	<input checked="" type="checkbox"/>	<input checked="" type="checkbox"/>	<input checked="" type="checkbox"/>	
-	513-443-16A	513-443-16T	0.0001 in	0.016 in	0-4-0	±0.0002 in	0.0001 in	0.00004 in		0.3N or less	<input checked="" type="checkbox"/>	<input checked="" type="checkbox"/>	<input type="checkbox"/>	<input type="checkbox"/>	<input type="checkbox"/>	<input checked="" type="checkbox"/>	<input checked="" type="checkbox"/>	

\* Stem with ø6 dovetail groove is not included in the mass.  
 \* Be sure to perform calibration with reference gage, etc. after changing the contact point. The inside parts may be damaged when the contact point is changed due to the breakage.  
 In the case the of the significant deterioration during the operation, repair is required.

DIMENSIONS

Unit: mm

Order No.	L1	L2
513-445-10E	18.7	15.2
513-444-10E	20.9	17.4

Refer to MEASURING INSTRUMENTS CATALOG No. US-1004 for the accessories such as styli, stems with dovetail, holding bars, etc.



Coordinate Measuring Machines

Vision Measuring Systems

Form Measurement

Optical Measuring

Sensor Systems

Test Equipment and Seismometers

Digital Scale and DRO Systems

Small Tool Instruments and Data Management

**Whatever your challenges are, Mitutoyo supports you from start to finish.**

Mitutoyo is not only a manufacturer of top-quality measuring products but one that also offers qualified support for the lifetime of the equipment, backed by comprehensive services that ensure your staff can make the very best use of the investment.

Apart from the basics of calibration and repair, Mitutoyo offers product and metrology training, as well as IT support for the sophisticated software used in modern measuring technology. We can also design, build, test and deliver measuring solutions and even, if deemed cost-effective, take your critical measurement challenges in-house on a sub-contract basis.

**Mitutoyo**

Looking for measuring tools? Visit our website.