

Milwaukee®

MANUAL

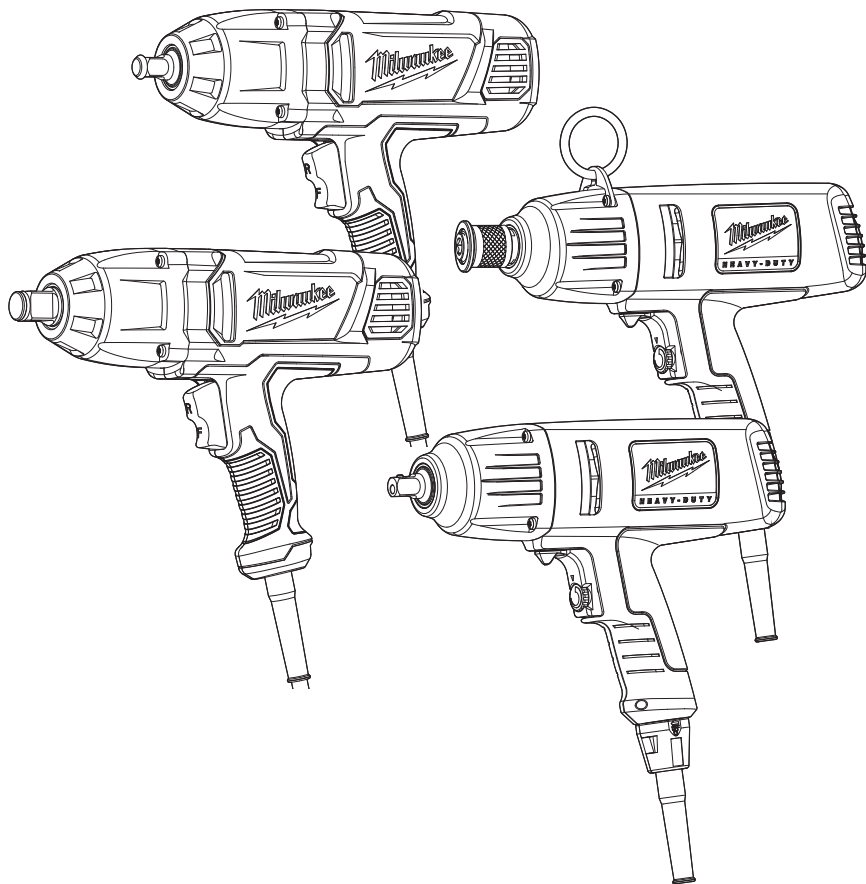

Cat. No. / No de cat.

9070-20, 9071-20, 9072-20, 9072-22, 9075-20, 9092-20, 9096-20

IMPACT WRENCH



WARNING To reduce the risk of injury, user must read and understand operator's manual.

GENERAL POWER TOOL SAFETY WARNINGS

⚠WARNING Read all safety warnings, instructions, illustrations and specifications provided with this power tool. Failure to follow all instructions listed below may result in electric shock, fire and/or serious injury. **Save all warnings and instructions for future reference.** The term "power tool" in the warnings refers to your mains-operated (corded) power tool or battery-operated (cordless) power tool.

WORK AREA SAFETY

- **Keep work area clean and well lit.** Cluttered or dark areas invite accidents.
- **Do not operate power tools in explosive atmospheres, such as in the presence of flammable liquids, gases or dust.** Power tools create sparks which may ignite the dust or fumes.
- **Keep children and bystanders away while operating a power tool.** Distractions can cause you to lose control.

ELECTRICAL SAFETY

- **Power tool plugs must match the outlet.** Never modify the plug in any way. Do not use any adapter plugs with earthed (grounded) power tools. Unmodified plugs and matching outlets will reduce risk of electric shock.
- **Avoid body contact with earthed or grounded surfaces, such as pipes, radiators, ranges and refrigerators.** There is an increased risk of electric shock if your body is earthed or grounded.
- **Do not expose power tools to rain or wet conditions.** Water entering a power tool will increase the risk of electric shock.
- **Do not abuse the cord.** Never use the cord for carrying, pulling or unplugging the power tool. **Keep cord away from heat, oil, sharp edges or moving parts.** Damaged or entangled cords increase the risk of electric shock.
- **When operating a power tool outdoors, use an extension cord suitable for outdoor use.** Use of a cord suitable for outdoor use reduces the risk of electric shock.
- **If operating a power tool in a damp location is unavoidable, use a ground fault circuit interrupter (GFCI) protected supply.** Use of an GFCI reduces the risk of electric shock.

PERSONAL SAFETY

- **Stay alert, watch what you are doing and use common sense when operating a power tool.** Do not use a power tool while you are tired or under the influence of drugs, alcohol or medication. A moment of inattention while operating power tools may result in serious personal injury.
- **Use personal protective equipment. Always wear eye protection.** Protective equipment such as a dust mask, non-skid safety shoes, hard hat or hearing protection used for appropriate conditions will reduce personal injuries.
- **Prevent unintentional starting.** Ensure the switch is in the off-position before connecting to power source and/or battery pack, picking up or carrying the tool. Carrying power tools with your finger on the switch or energizing power tools that have the switch on invites accidents.
- **Remove any adjusting key or wrench before turning the power tool on.** A wrench or a key left

attached to a rotating part of the power tool may result in personal injury.

- **Do not overreach. Keep proper footing and balance at all times.** This enables better control of the power tool in unexpected situations.
- **Dress properly. Do not wear loose clothing or jewelry. Keep your hair and clothing away from moving parts.** Loose clothes, jewelry or long hair can be caught in moving parts.
- **If devices are provided for the connection of dust extraction and collection facilities, ensure these are connected and properly used.** Use of dust collection can reduce dust-related hazards.
- **Do not let familiarity gained from frequent use of tools allow you to become complacent and ignore tool safety principles.** A careless action can cause severe injury within a fraction of a second.

POWER TOOL USE AND CARE

- **Do not force the power tool. Use the correct power tool for your application.** The correct power tool will do the job better and safer at the rate for which it was designed.
- **Do not use the power tool if the switch does not turn it on and off.** Any power tool that cannot be controlled with the switch is dangerous and must be repaired.
- **Disconnect the plug from the power source and/or remove the battery pack, if detachable, from the power tool before making any adjustments, changing accessories, or storing power tools.** Such preventive safety measures reduce the risk of starting the power tool accidentally.
- **Store idle power tools out of the reach of children and do not allow persons unfamiliar with the power tool or these instructions to operate the power tool.** Power tools are dangerous in the hands of untrained users.
- **Maintain power tools and accessories. Check for misalignment or binding of moving parts, breakage of parts and any other condition that may affect the power tool's operation. If damaged, have the power tool repaired before use.** Many accidents are caused by poorly maintained power tools.
- **Keep cutting tools sharp and clean.** Properly maintained cutting tools with sharp cutting edges are less likely to bind and are easier to control.
- **Use the power tool, accessories and tool bits etc. in accordance with these instructions, taking into account the working conditions and the work to be performed.** Use of the power tool for operations different from those intended could result in a hazardous situation.
- **Keep handles and grasping surfaces dry, clean and free from oil and grease.** Slippery handles and grasping surfaces do not allow for safe handling and control of the tool in unexpected situations.

SERVICE

- **Have your power tool serviced by a qualified repair person using only identical replacement parts.** This will ensure that the safety of the power tool is maintained.

SPECIFIC SAFETY RULES FOR IMPACT WRENCH

- **Hold the power tool by insulated gripping surfaces, when performing an operation where the fastener may contact hidden wiring or its own cord.** Fasteners contacting a "live" wire may make exposed metal parts of the power tool "live" and could give the operator an electric shock.

GROUNDING

- **Wear ear protectors when impact drilling.** Exposure to noise can cause hearing loss.
- **Use only sockets and other accessories specifically designed for use on impact wrenches and drivers.** Other sockets and accessories might shatter or break causing injury.
- **Maintain labels and nameplates.** These carry important information. If unreadable or missing, contact a MILWAUKEE service facility for a free replacement.

- **WARNING** Some dust created by power sanding, sawing, grinding, drilling, and other construction activities contains chemicals known to cause cancer, birth defects or other reproductive harm. Some examples of these chemicals are:
 - lead from lead-based paint
 - crystalline silica from bricks and cement and other masonry products, and
 - arsenic and chromium from chemically-treated lumber.

Your risk from these exposures varies, depending on how often you do this type of work. To reduce your exposure to these chemicals: work in a well ventilated area, and work with approved safety equipment, such as those dust masks that are specially designed to filter out microscopic particles.

EXTENSION CORDS

Grounded tools require a three wire extension cord. Double insulated tools can use either a two or three wire extension cord. As the distance from the supply outlet increases, you must use a heavier gauge extension cord. Using extension cords with inadequately sized wire causes a serious drop in voltage, resulting in loss of power and possible tool damage. Refer to the table shown to determine the required minimum wire size.

The smaller the gauge number of the wire, the greater the capacity of the cord. For example, a 14 gauge cord can carry a higher current than a 16 gauge cord. When using more than one extension cord to make up the total length, be sure each cord contains at least the minimum wire size required. If you are using one extension cord for more than one tool, add the nameplate amperes and use the sum to determine the required minimum wire size.

Guidelines for Using Extension Cords

- If you are using an extension cord outdoors, be sure it is marked with the suffix "W-A" ("W" in Canada) to indicate that it is acceptable for outdoor use.
- Be sure your extension cord is properly wired and in good electrical condition. Always replace a damaged extension cord or have it repaired by a qualified person before using it.
- Protect your extension cords from sharp objects, excessive heat and damp or wet areas.

Nameplate Amps	Extension Cord Length				
	25'	50'	75'	100'	150'
0 - 2.0	18	18	18	18	16
2.1 - 3.4	18	18	18	16	14
3.5 - 5.0	18	18	16	14	12
5.1 - 7.0	18	16	14	12	12
7.1 - 12.0	16	14	12	10	--
12.1 - 16.0	14	12	10	--	--
16.1 - 20.0	12	10	--	--	--

* Based on limiting the line voltage drop to five volts at 150% of the rated amperes.

WARNING Improperly connecting the grounding wire can result in the risk of electric shock. Check with a qualified electrician if you are in doubt as to whether the outlet is properly grounded. Do not modify the plug provided with the tool. Never remove the grounding prong from the plug. Do not use the tool if the cord or plug is damaged. If damaged, have it repaired by a MILWAUKEE service facility before use. If the plug will not fit the outlet, have a proper outlet installed by a qualified electrician.

Grounded Tools (Three-Prong Plugs)

Tools marked "Grounding Required" have a three wire cord and three prong grounding plug. The plug must be connected to a properly grounded outlet (See Figure A). If the tool should electrically malfunction or break down, grounding provides a low resistance path to carry electricity away from the user, reducing the risk of electric shock.

The grounding prong in the plug is connected through the green wire inside the cord to the grounding system in the tool. The green wire in the cord must be the only wire connected to the tool's grounding system and must never be attached to an electrically "live" terminal.

Your tool must be plugged into an appropriate outlet, properly installed and grounded in accordance with all codes and ordinances. The plug and outlet should look like those in Figure A.

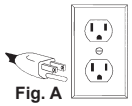

Fig. A

Double Insulated Tools (Two-Prong Plugs)

Tools marked "Double Insulated" do not require grounding. They have a special double insulation system which satisfies OSHA requirements and complies with the applicable standards of Underwriters Laboratories, Inc., the Canadian Standard Association and the National Electrical Code. Double Insulated tools may be used in either of the 120 volt outlets shown in Figures B and C.

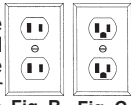

Fig. B

Fig. C

SYMBOLOLOGY



Double Insulated



Amps



Volts



Alternating Current



Alternating Current/Direct Current

n XXXX min⁻¹ Impacts per Minute Under Load (IPM)



UL Listing for Canada and U.S.



Approval Mark for Mexico

SPECIFICATIONS

Volts.....	120 AC
Amps.....	7
Cat. No.	9070-20
No Load RPM.....	1800
Drive Shaft.....	1/2"
Impacts per Minute.....	2600
Average Torque.....	300 ft-lbs
Cat. No.	9071-20
No Load RPM.....	1800
Drive Shaft.....	1/2"
Impacts per Minute.....	2600
Average Torque.....	300 ft-lbs
Cat. No.	9072-20
No Load RPM.....	600-1800
Drive Shaft.....	1/2"
Impacts per Minute.....	1000-2600
Average Torque.....	100-300 ft-lbs
Cat. No.	9072-22
No Load RPM.....	600-1800
Drive Shaft.....	1/2"
Impacts per Minute.....	1000-2600
Average Torque.....	100-300 ft-lbs
Cat. No.	9075-20
No Load RPM.....	1800
Drive Shaft.....	3/4"
Impacts per Minute.....	2500
Average Torque.....	380 ft-lbs
Cat. No.	9092-20
No Load RPM.....	600-1800
Drive Shaft.....	1/16" Hex
Impacts per Minute.....	1000-2600
Average Torque.....	100-315 ft-lbs
Cat. No.	9096-20
No Load RPM.....	600-1800
Drive Shaft.....	5/8" Hex
Impacts per Minute.....	1000-2600
Average Torque.....	100-315 ft-lbs

QUICKCHANGECHUCK CAPACITIES*

Cat. No.	9070-20
Quick Change Auger Bits.....	1-1/2"
Selffeed Bits.....	2-9/16"
Cat. No.	9072-20
Quick Change Auger Bits.....	1-1/2"
Selffeed Bits.....	2-9/16"
Cat. No.	9072-22
Quick Change Auger Bits.....	1-1/2"
Selffeed Bits.....	2-9/16"
Cat. No.	9092-20
Quick Change Auger Bits.....	1-1/2"
Selffeed Bits.....	2-9/16"
Cat. No.	9076-20
Quick Change Auger Bits.....	1-1/2"
Selffeed Bits.....	2-9/16"

*Only for use with the 7/16" or 5/8" Hex Quick Change chuck, standard equipment on the 9092-20 (7/16") and 9096-20 (5/8"), optional accessory (Cat. No. 48-66-0061) on other models.

FUNCTIONAL DESCRIPTION

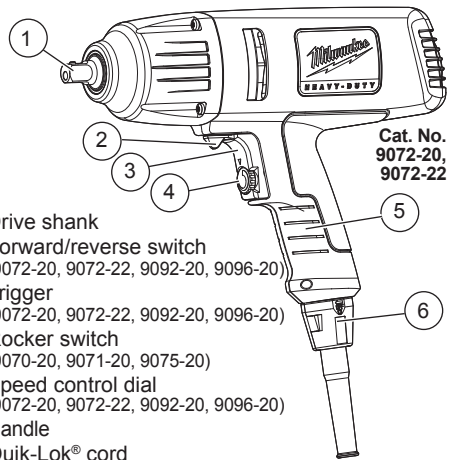

Cat. No. 9072-20, 9072-22

1. Drive shank
2. Forward/reverse switch (9072-20, 9072-22, 9092-20, 9096-20)
3. Trigger (9072-20, 9072-22, 9092-20, 9096-20)
Rocker switch (9070-20, 9071-20, 9075-20)
4. Speed control dial (9072-20, 9072-22, 9092-20, 9096-20)
5. Handle
6. Quik-Lok® cord (9072-20, 9072-22, 9092-20, 9096-20)
7. Quick change chuck (9092-20, 9096-20)
8. Tool hanger (9092-20, 9096-20)
9. Tool hanger ring (9092-20, 9096-20)

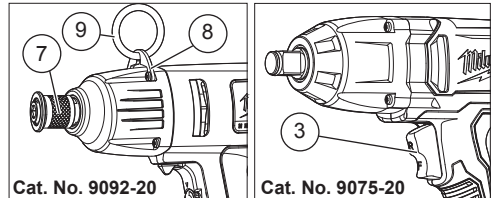

Cat. No. 9092-20

Cat. No. 9075-20

ASSEMBLY

WARNING To reduce the risk of injury, always unplug tool before changing or removing accessories. Only use accessories specifically recommended for this tool. Others may be hazardous.

Removing and Replacing Quik-Lok® Cords (Cat. No. 9072-20, 9072-22, 9092-20 and 9096-20)

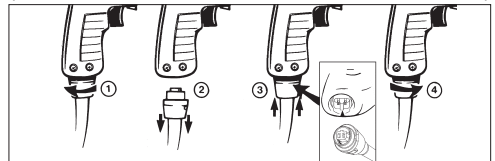

MILWAUKEE's exclusive Quik-Lok® Cords provide instant field replacement or substitution.

1. To remove the Quik-Lok® Cord, turn the cord nut 1/4 turn to the left and pull it out.
2. To replace the Quik-Lok® Cord, align the connector keyways and push the connector in as far as it will go. Turn the cord nut 1/4 turn to the right to lock.

Attaching and Removing the Tool Hanger

(Cat. No. 9092-20, 9096-20, or as accessory)

1. To **attach**, remove the two top gear case screws.
2. Place the ring through the tool hanger.
3. Position the tool hanger on the tool over the two gear case screw holes.
4. Replace the two gear case screws. Hand tighten the screws.
5. To **remove**, reverse the procedure.

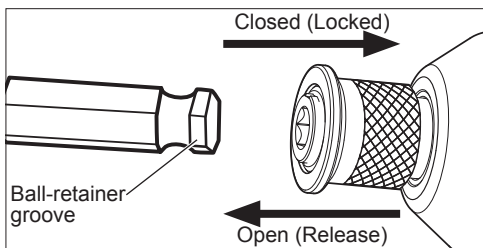
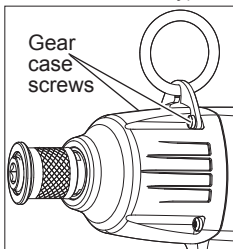

OPERATION

WARNING To reduce the risk of injury, always unplug tool before attaching or removing accessories or making adjustments. Use only specifically recommended accessories. Others may be hazardous.

To reduce the risk of injury, always wear safety goggles or glasses with side shields.

Using the Forward/Reverse Switch

(Cat. No. 9072-20, 9072-22, 9092-20, and 9096-20) This impact wrench is equipped with a forward/reverse switch that may be set to forward or reverse rotation.

1. For **forward** (clockwise) rotation, push the forward/reverse switch in the direction shown. **Check the direction of rotation before use.**
2. For **reverse** (counterclockwise) rotation, push the forward/reverse switch in the direction shown. **Check the direction of rotation before use.**

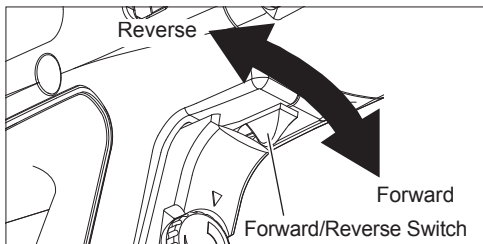

WARNING To reduce the risk of injury, keep hands and cord away from the bit and all moving parts.

To reduce the risk of explosion, electric shock and property damage, always check the work area for hidden pipes and wires before drilling.

To reduce the risk of injury, only grasp tool by handle and red insulated surfaces. Do not hold gray gear case when impacting or drilling.

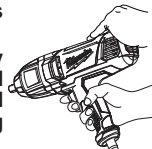

Attaching and Removing Accessories

(Cat. No. 9071-20, 9075-20)

This impact wrench is intended only for use with sockets designed for impact wrenches and that have a 1/2" square drive (3/4" square drive for Cat. No. 9075-20). Other sockets could shatter or break, causing injury.

1. To attach a socket or other accessory, push the accessory onto the drive shank until it snaps into place.
2. To remove the accessory, pull it off the drive shank.

Attaching and Removing Accessories

(Cat. No. 9070-20, 9072-20, 9072-22)

These impact wrenches are intended only for use with sockets designed for impact wrenches and that have a 1/2" square drive. Other sockets could shatter or break, causing injury.

1. To attach a socket or other accessory, align the hole in the accessory with the detent pin on the drive shank. Hold the detent pin in while pushing the socket onto the drive shank. The detent pin will snap into place in the hole to secure the socket.
2. To remove the accessory, insert a nail or other thin object into the hole in the accessory and press the detent pin in. Pull the accessory off the drive shank.

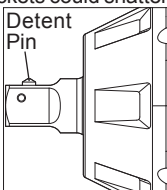

Attaching and Removing Accessories

(Cat. No. 9092-20, 9096-20, or other Impact Wrenches using the Quick Change 1/2" Square Drive to 7/16" Hex Adapter)

Cat. No. 9092-20 and accessory Cat. No. 48-66-0061 are intended for use with accessories with a 7/16" Hex Quick Change shank. Cat. No. 9096-20 is intended for use with accessories with a 5/8" Hex Quick Change shank. Both Hex Quick Change shanks have a ball-retainer groove. They are not intended for use with Hex Shank Bit Extensions.

1. To attach an accessory, pull the chuck collar forward and insert the accessory shank. Release the collar. It may be necessary to pull the bit out slightly to engage the holding mechanism.
2. To remove the accessory, pull the chuck collar forward and remove the accessory. Release the collar.

Starting, Stopping and Controlling Speed

(9072-20, 9072-22, 9092-20, and 9096-20)

This impact wrench may be operated at any speed from 0 to full speed. The speed will remain variable up to the chosen speed dial setting by use of the trigger. The speed dial turns clockwise to increase the speed or counterclockwise to decrease the speed.

1. Select a speed on the speed dial.
2. To **start** the tool, pull the trigger.
3. To **vary** the driving speed, increase or decrease pressure on the trigger. The further the trigger is pulled, the greater the speed.
4. To **stop** the tool, release the trigger.

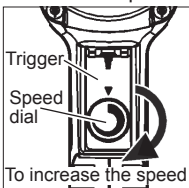

Starting and Stopping the Tool

(9070-20, 9071-20, 9075-20)

These impact wrenches are equipped with a rocker switch that offers both forward and reverse rotation.

1. For **forward** (clockwise) rotation, pull the lower portion of the switch.
2. For **reverse** (counterclockwise) rotation, pull the upper portion of the switch.

NOTE: To prevent damage to the motor and internal mechanism, allow the motor to stop completely before switching from forward to reverse or from reverse to forward.

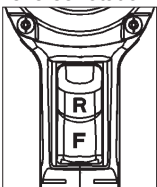

Impacting Techniques

The longer a bolt, screw, or nut is impacted, the tighter it will become. To help prevent damaging the fasteners or workpieces, avoid excessive impacting. Be particularly careful when impacting smaller fasteners because they require less impacting to reach optimum torque.

Practice with various fasteners, noting the length of time required to reach the desired torque. Check the tightness with a hand-torque wrench. If the fasteners are too tight, reduce the impacting time. If they are not tight enough, increase the impacting time.

Impacting for two seconds is generally sufficient for a 3/8" bolt and one second for a 5/16" bolt. However, oil, dirt, rust or other matter on the threads or under the head of the fastener affects the degree of tightness.

The torque required to loosen a fastener averages 75% to 80% of the tightening torque, depending on the condition of the contacting surfaces. However, if rust or corrosion causes seizing, more torque may be required.

On light gasket jobs, run each fastener down to a relatively light torque and use a hand torque wrench for final tightening.

MAINTENANCE

WARNING To reduce the risk of injury, always unplug the tool before performing any maintenance. Never disassemble the tool. Contact a MILWAUKEE service facility for ALL repairs.

Maintaining Tools

Keep your tool in good repair by adopting a regular maintenance program. Inspect your tool for issues such as undue noise, misalignment or binding of moving parts, breakage of parts, or any other condition that may affect the tool operation. Return the tool to a MILWAUKEE service facility for repair. After six months to one year, depending on use, return the tool to a MILWAUKEE service facility for inspection.

WARNING To reduce the risk of personal injury, electric shock and damage, never immerse your tool in liquid or allow a liquid to flow inside it.

Cleaning

Clean dust and debris from vents. Keep handles clean, dry and free of oil or grease. Use only mild soap and a damp cloth to clean, since certain cleaning agents and solvents are harmful to plastics and other insulated parts. Some of these include gasoline, turpentine, lacquer thinner, paint thinner, chlorinated cleaning solvents, ammonia and household detergents containing ammonia. Never use flammable or combustible solvents around tools.

Repairs

For repairs, return the tool to the nearest service center.

ACCESSORIES

WARNING Use only recommended accessories. Others may be hazardous.