

# WIRING INSTRUCTIONS

TITLE

**METAL CUTTING SAW**

DATE  
Apr. 2005

**BULLETIN  
58-01-0085**

Place the terminal (T2) from the yellow field wire #8 on the back tab of the brush holder assembly.

Place the terminal from brush shunt on the front tab of the brush holder assembly.

Same orientation on the other side.

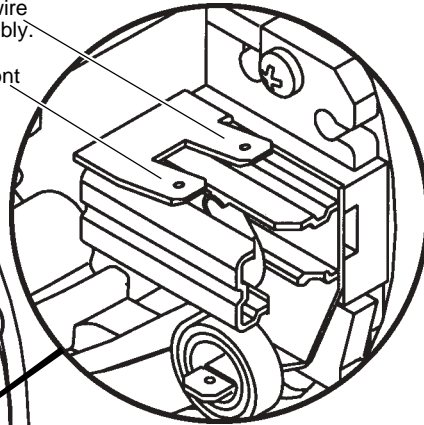
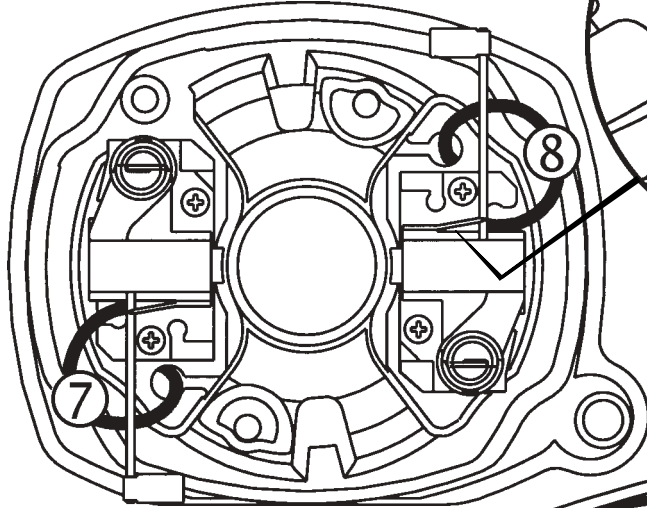

Black wires #1 and #3 are interchangeable at the top of the switch.

White wires #2 and #4 are interchangeable at the bottom of the switch.

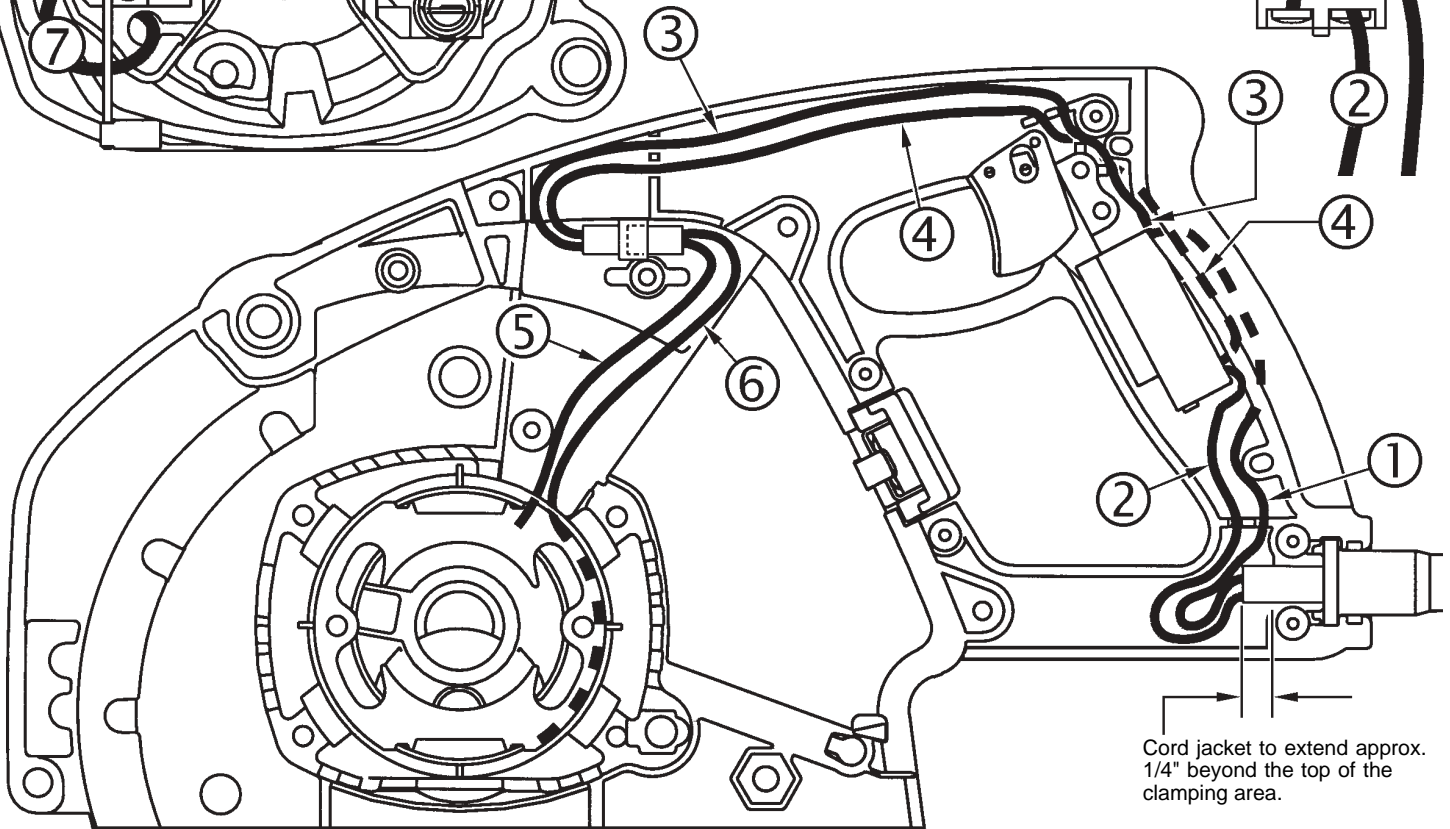
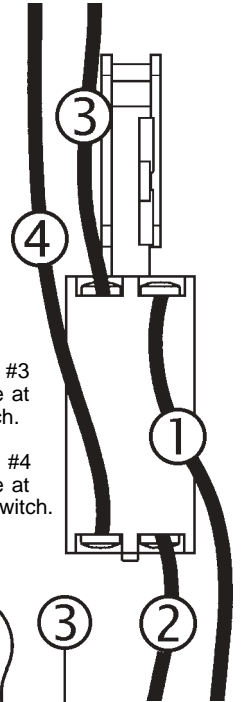

Cord jacket to extend approx. 1/4" beyond the top of the clamping area.

## WIRING SPECIFICATIONS

Wire No.	Wire Color	Origin or Gauge	Length	Terminals, Connectors and 1 or 2 End Wire Preparation
1	Black	Cord Set	----	Component of the cord set. Strip 3/16" for T1.
2	White	Cord Set	----	Component of the cord set. Strip 3/16" for T1.
3	Black	23-94-0010	----	Component of the leadwire assembly. Strip 3/16" for T1.
4	White	23-94-0010	----	Component of the leadwire assembly. Strip 3/16" for T1.
5	White	Field	----	Component of the field assembly.
6	Black	Field	----	Component of the field assembly.
7	Yellow	Field	----	Component of the field assembly. Strip 1/8" for T2.
8	Yellow	Field	----	Component of the field assembly. Strip 1/8" for T2.

**SEE REVERSE  
SIDE FOR WIRING  
WITH OVERLOAD  
PROTECTION**

## TERMINAL DESCRIPTION

Code	Part No.	Qty.
T1	23-74-0120	4
T2	23-74-0750	2

**BULK LEAD WIRE - BULLETIN NO. 58-01-0003**

Place the terminal (T2) from the yellow field wire #8 on the back tab of the brush holder assembly.

Place the terminal from brush shunt on the front tab of the brush holder assembly.

Same orientation on the other side.

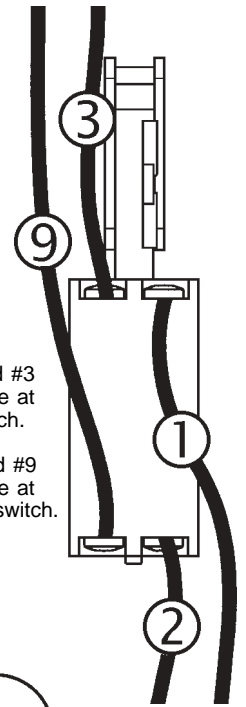
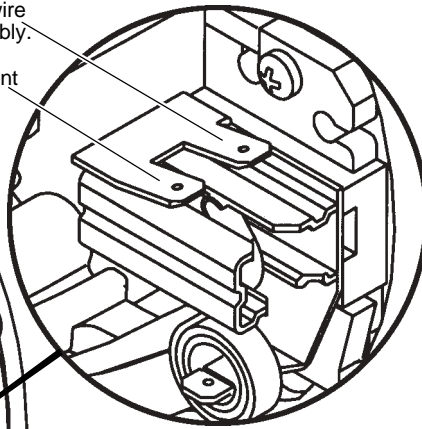
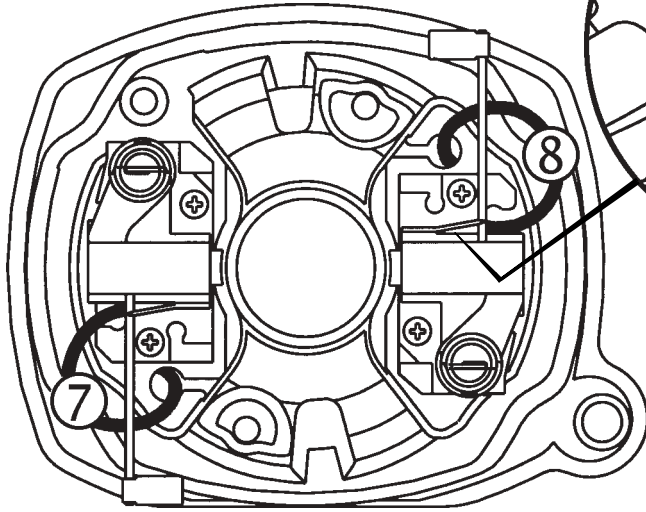

Black wires #1 and #3 are interchangeable at the top of the switch.

White wires #2 and #9 are interchangeable at the bottom of the switch.

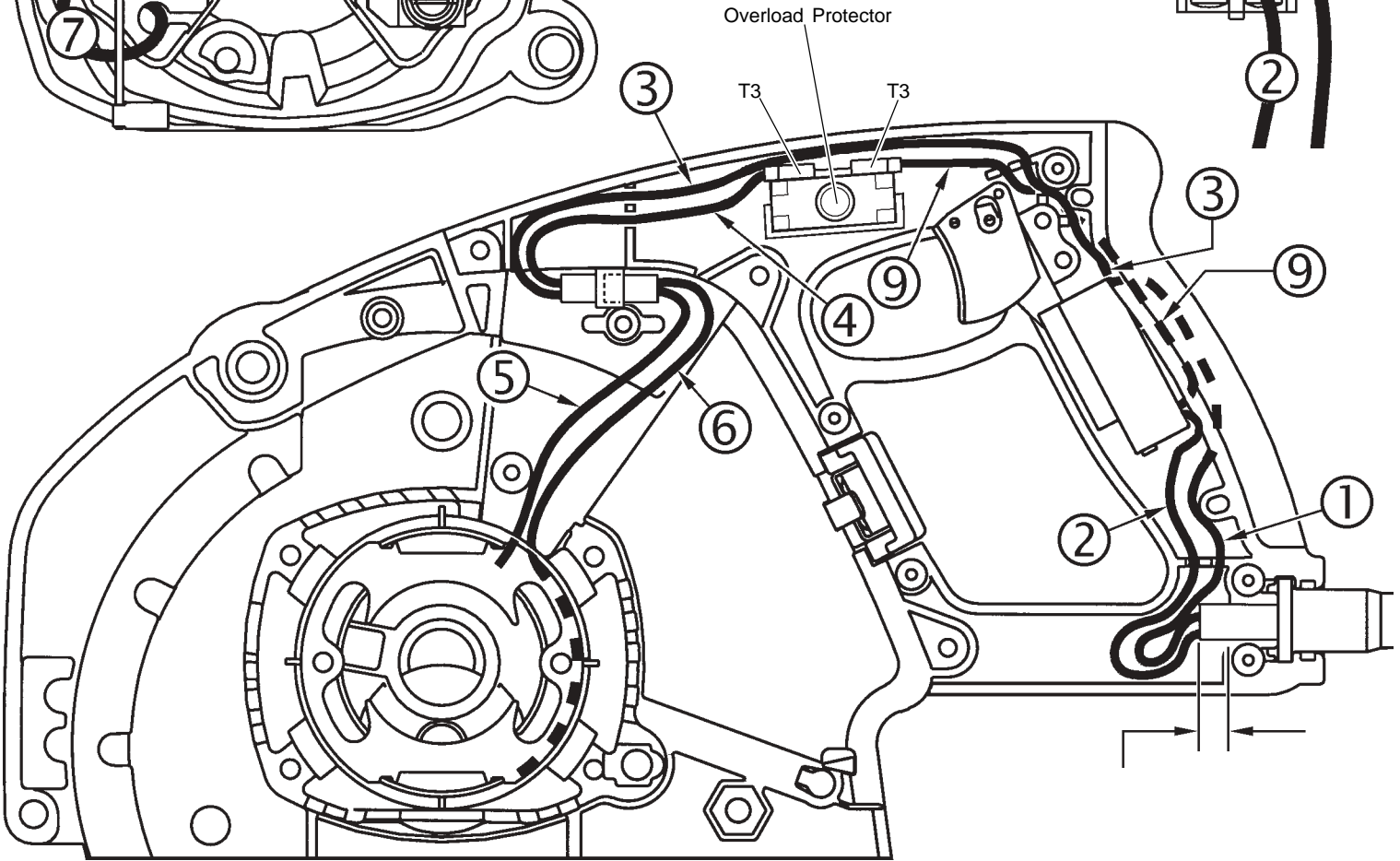

### WIRING SPECIFICATIONS

Wire No.	Wire Color	Origin or Gauge	Length	Terminals, Connectors and 1 or 2 End Wire Preparation
1	Black	Cord Set	----	Component of the cord set. Strip 3/16" for T1.
2	White	Cord Set	----	Component of the cord set. Strip 3/16" for T1.
3	Black	23-94-0011	----	Component of the leadwire assembly.
4	White	23-94-0011	----	Component of the leadwire assembly. Strip 5/16" for T3.
5	White	Field	----	Component of the field assembly.
6	Black	Field	----	Component of the field assembly.
7	Yellow	Field	----	Component of the field assembly. Strip 1/8" for T2.
8	Yellow	Field	----	Component of the field assembly. Strip 1/8" for T2.
9	White	23-94-0011	----	Component of the leadwire assembly. Strip 5/16" for T3.

BULK LEAD WIRE - BULLETIN NO. 58-01-0003

**SEE REVERSE SIDE FOR WIRING WITHOUT OVERLOAD PROTECTION**

### TERMINAL DESCRIPTION

Code	Part No.	Qty.
T1	23-74-0120	4
T2	23-74-0750	2
T3	23-74-1130	2