



# SERVICE PARTS LIST

**BULLETIN NO.**  
54-38-2320

SPECIFY CATALOG NO. AND SERIAL NO. WHEN ORDERING PARTS			REVISED BULLETIN
4.5" COMPACT ANGLE GRINDER with PADDLE SWITCH with lock-on			
<b>CAT. NO.</b>	<b>6142-30</b>	<b>STARTING SERIAL NUMBER</b>	<b>H40A</b>

FIG.	PART NO.	DESCRIPTION OF PART	NO. REQ.
1	05-88-1650	M4 x 25mm Pan Hd. ST Screw T-20	(4)
2	42-62-0120	Side Handle Assembly	(1)
3	14-30-0082	Gear Case Assembly	(1)
3g	02-04-0620	Ball Bearing	(1)
4	34-40-0180	O-Ring	(1)
5	14-73-0460	Spindle Hub Assembly	(1)
5d	-----	Steel Pin	(1)

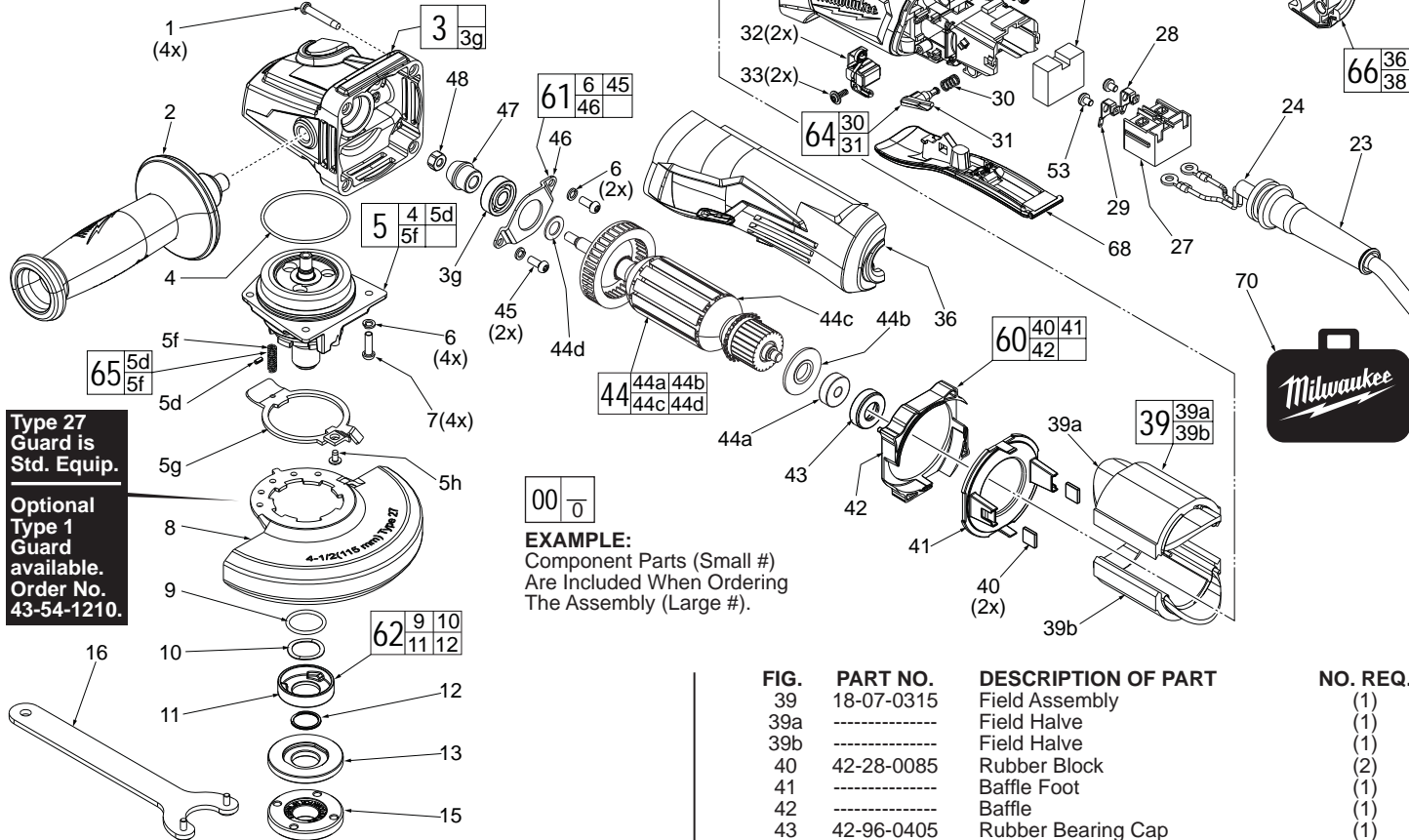

**Type 27 Guard is Std. Equip.**  
**Optional Type 1 Guard available. Order No. 43-54-1210.**

**EXAMPLE:**  
Component Parts (Small #)  
Are Included When Ordering  
The Assembly (Large #).

FIG.	PART NO.	DESCRIPTION OF PART	NO. REQ.
5f	-----	Spring	(1)
5g	44-20-0155	Guard Locking Tang	(1)
5h	05-81-0020	M3 x 5mm Pan Hd. ST T-8 Screw	(1)
6	05-90-0225	Spring Washer	(6)
7	05-88-1210	M4 x 14mm Pan Hd. Mach. T-20 Screw	(4)
8	43-54-1200	4.5" Type 27 Guard (Standard Equip.)	(1)
9	-----	O-Ring	(1)
10	-----	Wavey Spring	(1)
11	-----	Flange with Ramps	(1)
12	-----	Retaining Ring	(1)
13	43-34-0935	Inner Disc Flange	(1)
15	44-40-0035	Outer Flange Nut	(1)
16	49-96-7215	Spanner Wrench	(1)
21	05-88-1300	M4 x 28mm Pan Hd. ST T-20 Screw	(2)
22	05-88-1200	M4 x 16mm Pan Hd. ST T-20 Screw	(2)
23	44-76-0095	Cord Protector	(1)
24	22-64-2021	Power Cord	(1)
26	22-09-0720	PCBA	(1)
27	23-66-2665	On-Off Switch	(1)
28	23-74-1620	Brass Terminal	(1)
29	23-74-1615	Brass Terminal	(1)
30	-----	Spring	(1)
31	-----	Lock Button	(1)
32	22-18-2240	Carbon Brush Assembly (Set of 2)	(1)
33	05-88-0030	M3 x 8.5mm Pan Hd. ST T-10 Screw	(2)
34	31-50-6140	Motor Housing	(1)
35	23-16-0075	Foam Block	(1)
36	-----	Handle Support, Left Handle Halve	(1)
37	22-56-0150	Closed End Wire Connector	(1)
38	-----	Handle Cover, Right Handle Halve	(1)

FIG.	PART NO.	DESCRIPTION OF PART	NO. REQ.
39	18-07-0315	Field Assembly	(1)
39a	-----	Field Halve	(1)
39b	-----	Field Halve	(1)
40	42-28-0085	Rubber Block	(2)
41	-----	Baffle Foot	(1)
42	-----	Baffle	(1)
43	42-96-0405	Rubber Bearing Cap	(1)
44	16-10-0850	Armature Assembly	(1)
44a	02-04-2110	Ball Bearing	(1)
44b	31-86-0090	Plastic Disc	(1)
44c	-----	Armature	(1)
44d	45-88-0406	Washer	(1)
45	05-88-1280	M4 x 10mm Pan Hd. Mach. T-20 Screw	(2)
46	44-86-0155	Bearing Retainer	(1)
47	32-60-0301	Pinion	(1)
48	05-55-0620	M5 Hex Nut	(1)
49	12-20-6142	Service Nameplate (Not Shown)	(1)
50	10-20-6142	Warning Label (Not Shown)	(1)
53	05-78-0305	M3.5 x 7mm Pan Hd. Phillips Screw	(2)
60	42-14-0520	Baffle Assembly	(1)
61	44-86-0145	Bearing Retaining Plate Assembly	(1)
62	14-46-6105	Flange with Ramps Assembly	(1)
64	14-46-0231	Lock Button Kit	(1)
65	14-46-0241	Spring/Pin Kit	(1)
66	31-44-6100	Handle Set	(1)
68	31-92-0210	Paddle Trigger Assembly	(1)
70	42-55-6148	Canvas Tool Bag	(1)

**FIG. 3,5,47 LUBRICATION**  
**Use Type 'Y' Grease, No. 49-08-5270**  
When servicing the Gear Case Assembly (3), Pinion (47) or the Spindle Hub Assembly (5):  
90-95% of the old grease must be removed prior to any new grease being added. Be sure that all gear teeth are heavily coated when reassembling.

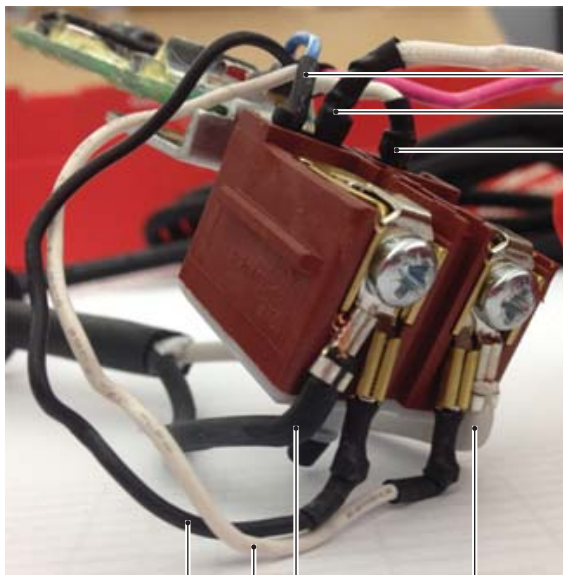

- Blue from PCBA
- White from bottom right Field
- White (thick) from PCBA

- Black from PCBA
- White (thin) from PCBA
- Black from Power Cord
- White from Power Cord

Route and trap wires as shown in the illustrations below. Be sure to place all components firmly and squarely in handle halve cavities. Be sure the wires are pushed to the bottom of wire traps. Check for any interferences prior to installing the handle cover. Check for proper switch and lock movement before activating the tool.

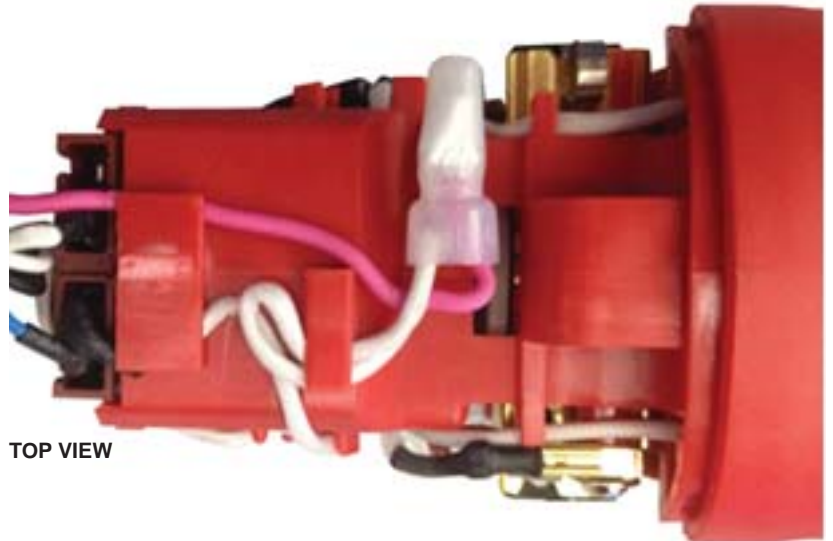

TOP VIEW



**HANDLE SUPPORT (Left Handle Halve)**  
Install all components and route wires here before securing with Handle Cover.



**HANDLE COVER (Right Handle Halve)**