



# SERVICE PARTS LIST

BULLETIN NO.  
54-24-0680

SPECIFY CATALOG NO. AND SERIAL NO. WHEN ORDERING PARTS		REVISED BULLETIN 54-24-0679
<b>1/2" HAMMER-DRILL</b>		
CATALOG NO. <b>5378-20</b>	STARTING SERIAL NO. <b>897G</b>	WIRING INSTRUCTION <b>SEE PAGE 3</b>

**EXAMPLE:**  
00 0 Component Parts (Small #)  
Are Included When Ordering  
The Assembly (Large #).

★ = Part number change from  
previous service parts list.

**SEE REVERSE SIDE FOR  
SERVICE & GREASE NOTES**

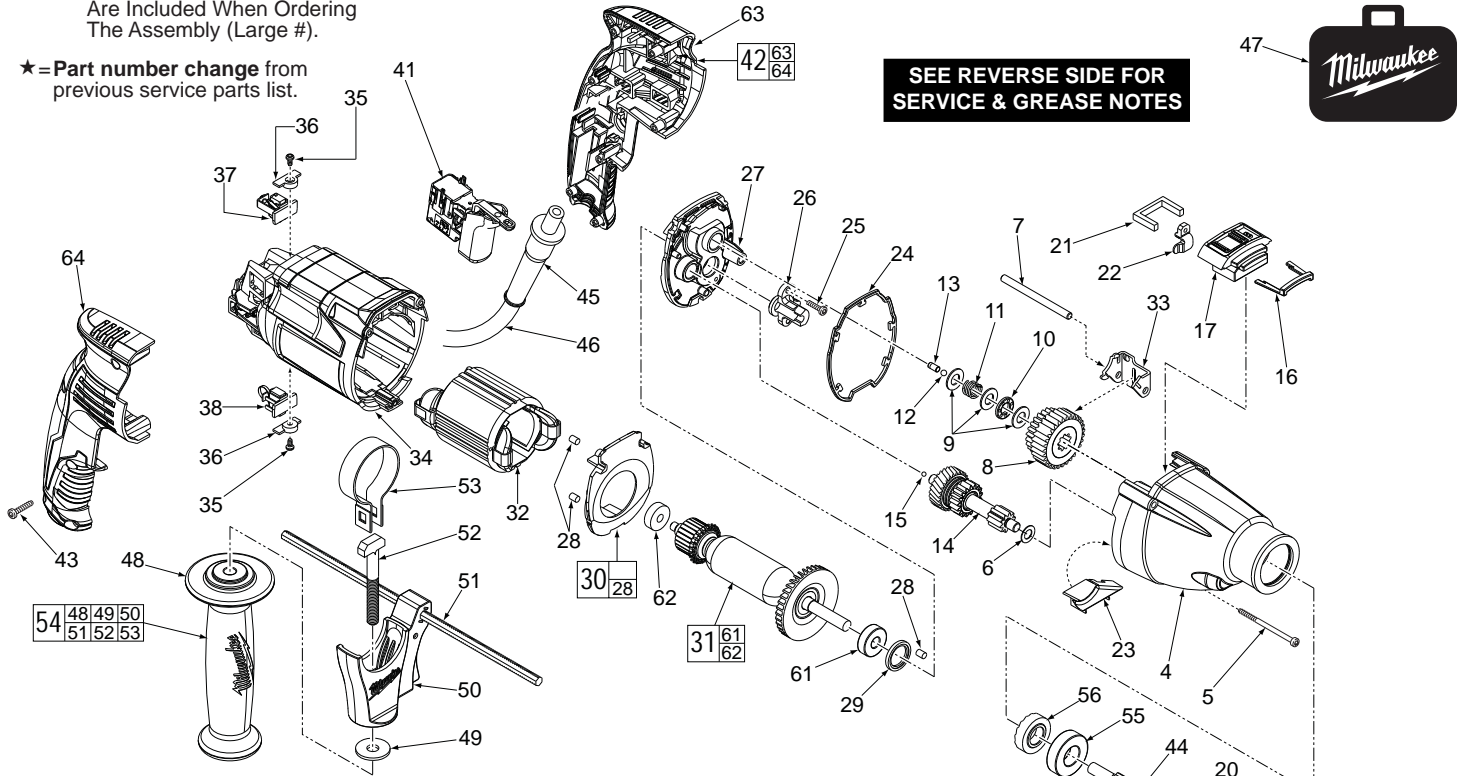

FIG.	PART NO.	DESCRIPTION OF PART	NO. REQ.
1	05-88-1500	M6 x 27 Chuck Screw	(1)
2	48-66-3280	Chuck Key	(1)
3	48-66-1355	Chuck (Incl. Chuck Key)	(1)
★ 4	28-14-5382	Gearcase Assembly (Incl. Needle Bearing, Fixed Ratchet and Shifting Assy.)	(1)
5	06-81-5380	M4 x 52 ST T-20 Screw	(3)
6	45-88-5381	Washer	(1)
7	44-94-5380	Pin	(1)
8	14-29-5378	1st and 2nd Spindle Gear Assembly	(1)
9	45-88-5378	Washer	(3)
10	02-80-5380	Thrust Bearing	(1)
11	40-50-5380	Spring	(1)
12	02-02-5380	Ball	(1)
13	44-60-5381	Pin	(1)
14	14-29-5379	Gear Shaft Assembly	(1)
15	02-02-0165	Ball	(1)
16	43-44-5381	Rubber Seal	(1)
17	14-34-5382	Selector Housing Assembly	(1)
18	34-80-5380	Retaining Ring	(1)
19	43-44-5380	Seal	(1)
20	45-88-5380	Washer	(1)
21	43-44-5378	Felt Seal	(1)
22	43-96-5380	Speed Selector Key	(1)
23	44-66-5381	Grease Plate	(1)
24	43-44-5379	Gasket	(1)
25	05-88-5380	M3.5 x 12 T-10 Screw	(2)
26	42-36-5378	Pinion Support	(1)
27	28-14-5378	Diaphragm Assy. (Incl. Washer & Bearings)	(1)
28	42-34-5380	Rubber Slug	(3)
29	43-44-5377	Seal Ring	(1)
30	14-34-5383	Baffle Assembly	(1)
31	16-07-5376	Service Armature Assembly	(1)
32	18-07-5376	Service Field	(1)
33	44-66-5378	Shifting Clip	(1)
34	31-50-5378	Motor Housing	(1)
35	06-81-5381	M3 x 6 Pan Hd. Phillips Screw	(2)
36	44-66-5379	Brush Holder Retaining Plate	(2)
37	22-22-5380	Brush Assy.-w/pop-off (Incl. Spring & Holder)	(1)
38	22-22-5381	Brush Assy.-regular (Incl. Spring & Holder)	(1)

Apply a drop of Blue Loctite®  
thread locking adhesive to chuck  
screw (1) prior to installing onto  
spindle (44).

FIG.	PART NO.	DESCRIPTION OF PART	NO. REQ.
41	23-66-5380	Switch	(1)
42	14-34-5378	Rear Handle Assembly	(1)
43	05-88-1200	M4 x 16 Pan Hd. T-20 Screw	(7)
44	38-50-5380	Spindle Shaft	(1)
45	44-76-0210	Cord Protector	(1)
46	22-64-5378	Cord Set	(1)
47	42-55-5378	Carrying Case	(1)
48	31-05-5379	Side Handle	(1)
49	45-88-5377	Washer	(1)
50	14-34-5374	Side Handle Carrier Assembly	(1)
51	44-94-5381	Depth Gauge	(1)
52	05-81-5378	M8 x 53 Bolt	(1)
★ 53	40-50-5375	Side Handle Clamping Band	(1)
★ 54	14-34-5373	Side Handle Assembly	(1)
55	02-04-5380	Ball Bearing	(1)
56	44-84-5380	Rotating Ratchet	(1)
61	02-04-5381	Ball Bearing	(1)
62	02-04-5382	Ball Bearing	(1)
63	-----	Left Handle Halve	(1)
64	-----	Right Handle Halve	(1)
	12-20-5378	Service Nameplate Kit (Not Shown)	(1)
	48-66-4040	Chuck Key Holder (Not Shown)	(1)
	23-94-5381	Red Brush Leadwire Assembly (Not Shown)	(1)
	23-94-5379	Black Brush Leadwire Assy. (Not Shown)	(1)

## Service Notes

**DO NOT** attempt to disassemble selector housing assembly (17).

**NOTE:** Gasket (24), selector housing assembly (17), speed selector key (22), rubber seal (16) and felt seal (21) must be assembled onto the diaphragm assembly (27) prior to installing onto gearcase assembly (4).

1. Place gasket (24) onto diaphragm assembly (27).
- 2a. Assemble speed selector key (22) onto selector housing assembly (17). The speed selector key will be seated on a pin in a like-shaped cavity of the selector housing assembly.
- 2b. Saturate felt seal (21) with a lightweight oil and place in selector housing assembly (17) over selector key (22).
- 2c. Place rubber seal (16) onto other side of selector housing assembly (17).
- 2d. Orient the selector housing assembly (17) and the assembled components (16, 21 and 22) above the diaphragm assembly (27). All element should slide straight down onto the diaphragm with the speed selector key (22) sliding into slotted opening.
3. Assemble above listed parts onto gearcase assembly (4).

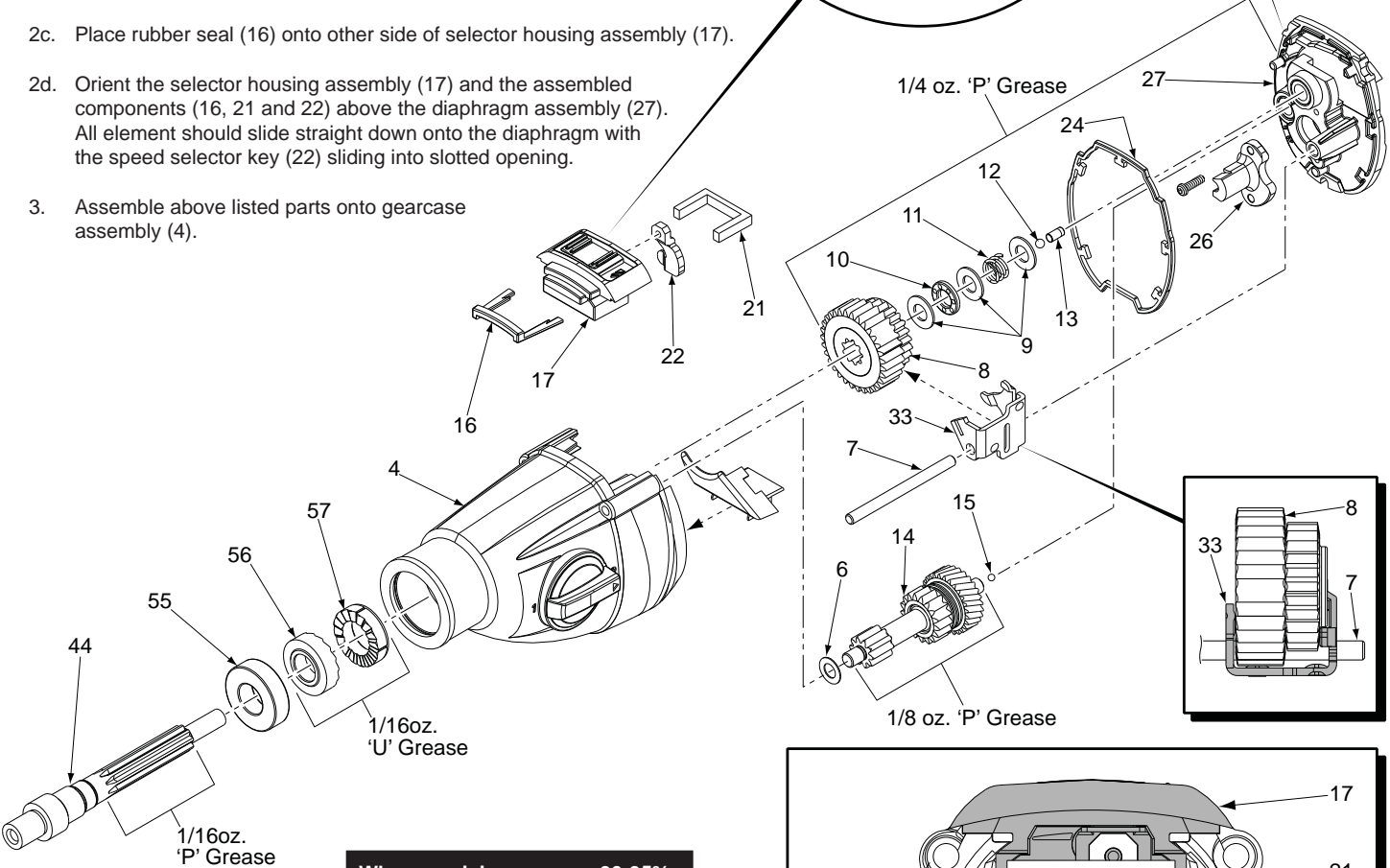
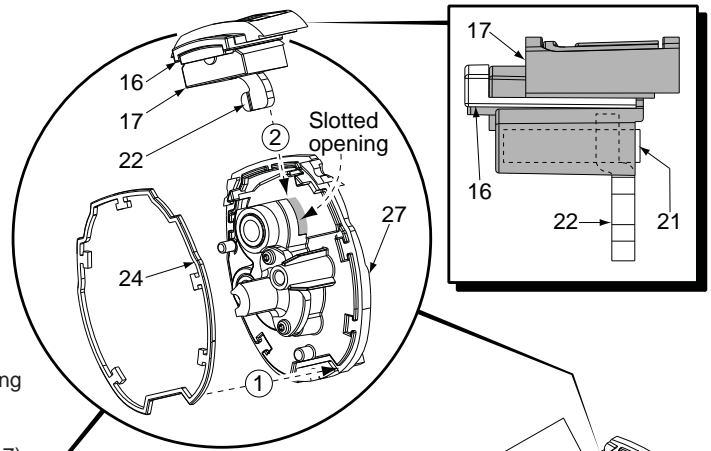

**When servicing, remove 90-95% of the existing grease prior to installing Type 'P' grease. Original grease maybe similar in color but not compatible with 'P'.**

## Lubrication Instructions

Type "P" (49-08-4250)  
Type "U" (49-08-0150)

1. Coat ratchets (56,57) with 1/16 oz. of Type "U" grease, No. 49-08-0150.
2. Coat spindle spline (44), ball (12) and pin (13) with 1/16 oz. of Type "P" grease, No. 49-08-4250.
3. Place 1/8 oz. of Type "P" grease, No. 49-08-4250, around the gear shaft assembly (14) area of gearcase (4) .
4. Lubricate gear assembly (parts 6,7,8,9,10,11,12,13,14,15,24,25,26,33,58, 59 and 60) using 1/4 oz. of Type "P" grease, No. 49-08-4250.

Total amount of lubrication: approximately 1/2 oz.

Saturate felt seal (21) with lightweight oil before assembling onto selector housing assembly (17).

Do not place gear shaft assembly (14) in solvent solution. Wipe off with a clean dry cloth.

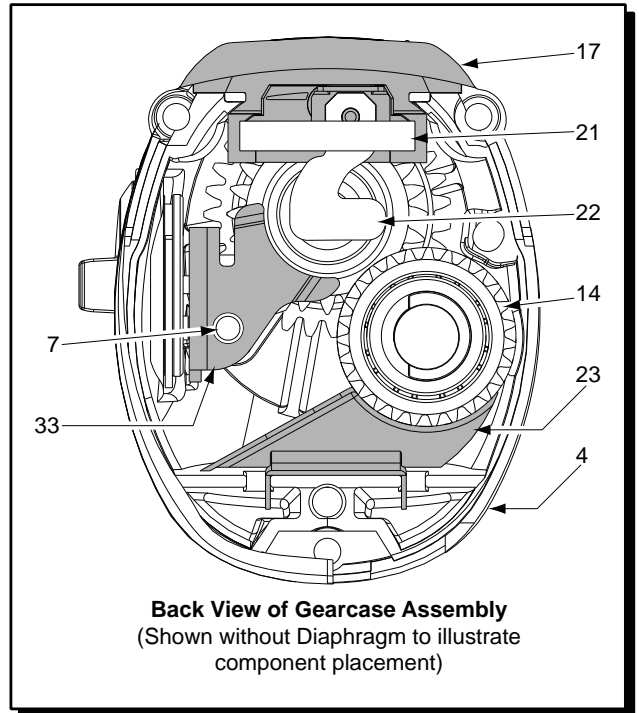

**Back View of Gearcase Assembly**  
(Shown without Diaphragm to illustrate component placement)

# WIRING INSTRUCTIONS

TITLE

1/2" HAMMER-DRILL

BULLETIN

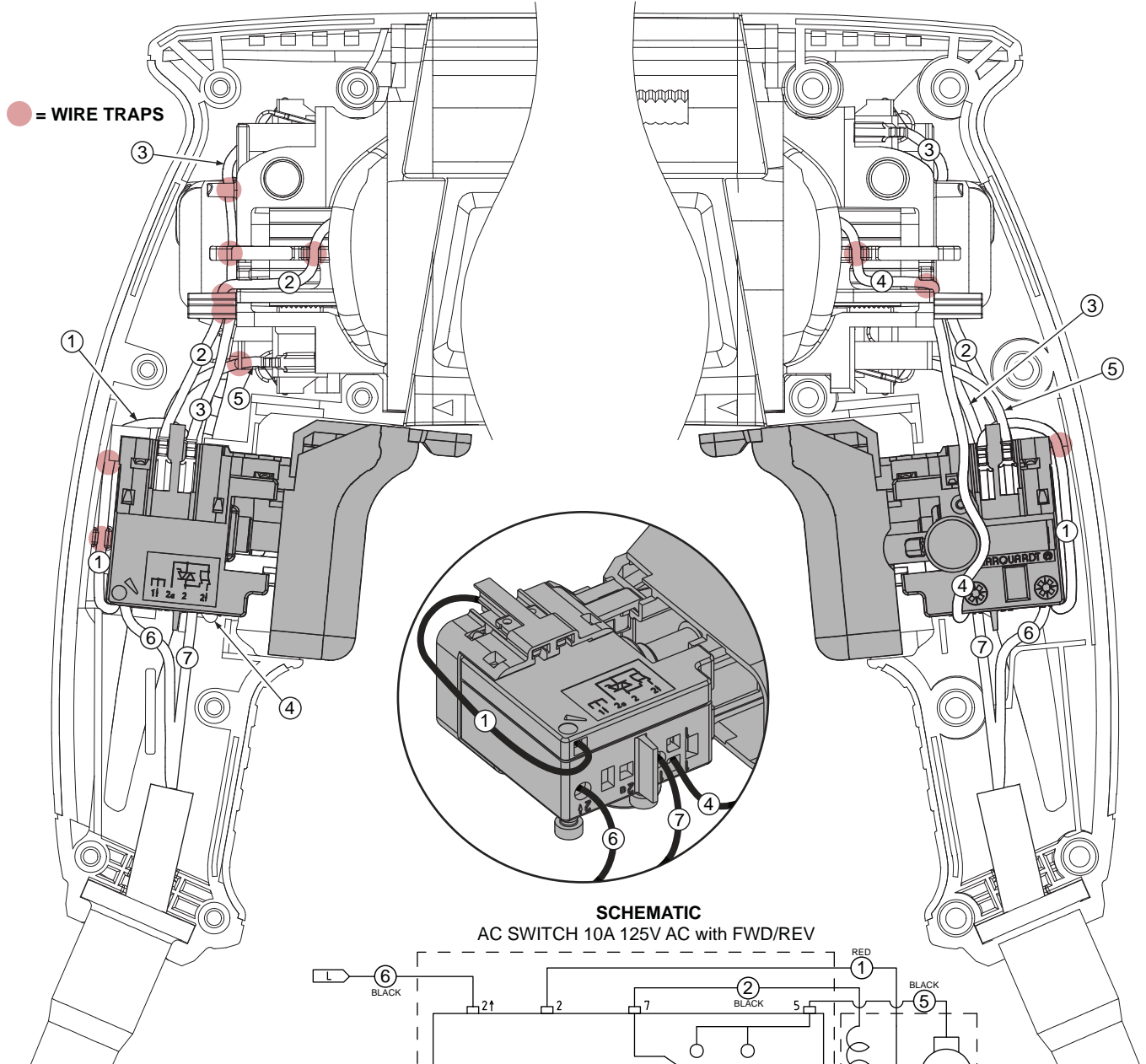

**SCHEMATIC**

AC SWITCH 10A 125V AC with FWD/REV

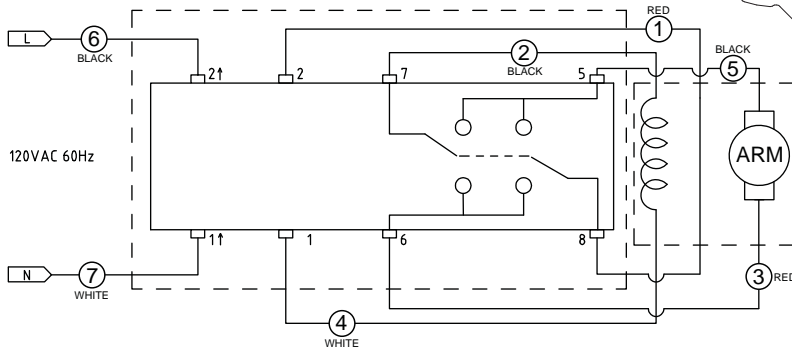

**NOTE:** As an aid to reassembly, take note of the wire routings and position of the wires in the wire guides and traps prior to dismantling the tool.

Watch for pinched wires when placing the handle cover back over the housing assembly.

**WIRING SPECIFICATIONS**

Wire No.	Wire Color	Origin or Gauge	Length	Terminals, Connectors and 1 or 2 End Wire Preparation
1	Red	Switch	-----	Non-terminated end to '2' and terminated end to '8' on switch.
2	Black	Field	-----	Route from field to '7' on switch.
3	Red	23-94-5381	-----	Connect to '6' on switch and route to top brush assembly.
4	White	Field	-----	Route from field to '1' on switch.
5	Black	23-94-5379	-----	Connect to '5' on switch and route to bottom brush assembly.
6	Black	Cord	-----	Connect to '2↑' on switch.
7	White	Cord	-----	Connect to '1↑' on switch.

**BULK LEAD WIRE - BULLETIN NO. 58-01-0003**

**NOTE:**

All leads must be held to ± 1/8". All lead lengths are before stripping.

**TERMINAL DESCRIPTION**

Code	Part No.	Qty.