



# SERVICE PARTS LIST

**BULLETIN NO.**  
**54-22-1030**

SPECIFY CATALOG NO. AND SERIAL NO. WHEN ORDERING PARTS		REVISED BULLETIN	DATE
<b>6" STRAIGHT GRINDER</b>			Apr. 2005
<b>CATALOG NO. 5243</b>	STARTING SERIAL NUMBER <b>663-1001</b>	WIRING INSTRUCTION <b>58-01-0307</b>	

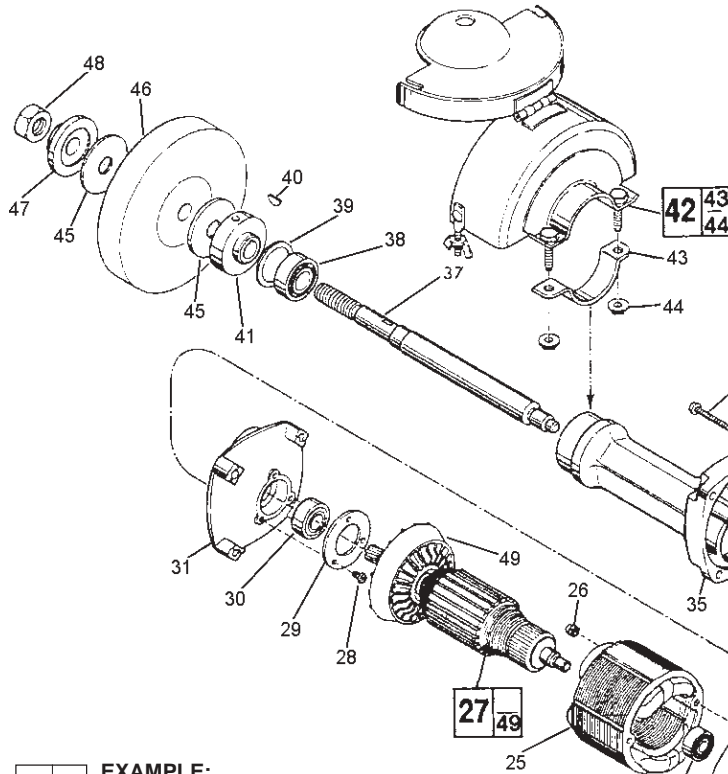

FIG.	PART NO.	DESCRIPTION OF PART	QTY.
31	28-28-0392	Diaphragm Assy. (Incl. 45-30-0120 BB Retaining Slug)	(1)
32	22-64-0076	Cord Set	(1)
33	02-04-0910	Ball Bearing	(1)
34	32-75-3160	Spindle Gear	(1)
35	28-50-0400	Spindle Housing	(1)
36	06-95-5650	1/4-20 x 1-1/2" Taptite Screw	(4)
37	38-50-5280	Spindle	(1)
38	02-04-1746	Ball Bearing	(1)
39	34-80-2700	Internal Retaining Ring	(1)
40	06-42-1200	Woodruff Key	(1)
41	43-34-0320	Inner Wheel Flange	(1)

**FOR CAT. NO. 5243-2 (240 V) TOOL USE:**  
**16-76-0155 Armature**  
**18-76-0100 Field**  
**22-64-4000 Cord Set**

**EXAMPLE:**  
 00 0 Component Parts (Small #) Are Included When Ordering The Assembly (Large #).

FIG.	PART NO.	DESCRIPTION OF PART	QTY.
1	06-81-4207	10-24 x 7/8" Phil. Pan Head Screw	(3)
2	31-44-0580	Right Handle Half	(1)
3	06-97-1800	Switch Lockwasher	(4)
4	06-55-1000	10-24 Hex Nut	(3)
5	31-44-0605	Left Handle Half	(1)
6	23-66-0255	Switch	(1)
7	06-95-0215	8-18 x 1/2" Pan Hd. Thread Form Screw	(1)
8	06-81-5650	10-24 x 7/8" Pan Hd. Taptite Screw	(4)
9	06-81-1170	10-32 x 3" Fil. Flat Hd. Screw	(2)
10	31-86-0160	Insulating Bushing	(2)
11	06-95-5200	Ground Screw	(1)
12	06-95-0209	8-32 x 3/8" Taptite Screw	(2)
13	22-22-0401	Brush Holder Assy. (Coarse Thread) Incl. 22-20-0360 Brush Tube & 23-44-0170 Cap	(2)
	22-22-0400	Brush Holder Assy. (Previous Fine Thread Assy.) Incl. 22-20-0360 Brush Tube	(2)
14	22-18-0145	Carbon Brush Assembly	(2)
15	23-44-0170	Brush Retaining Cap-Coarse Thread	(2)
	23-44-0140	Brush Retaining Cap-Fine Thread	(2)
16	28-50-6351	Motor Housing Assy. (Incl. 45-30-0120 BB Retaining Slug)	(1)
17	31-15-0310	Cover Plate	(1)
18	06-85-0200	Nameplate Screw	(2)
19	12-99-0241	Nameplate Blank	(1)
20	31-70-0135	Tool Rest	(1)
21	45-04-0530	Shoulder Screw	(2)
22	31-55-0110	Coil Shield	(1)
23	23-16-0950	Insulating Sleeve	(1)
24	02-04-0911	Ball Bearing	(1)
25	18-70-0100	120 Volt Field	(1)
26	06-57-3005	10-32 Locking Hex Nut	(2)
27	16-70-0155	120 Volt Armature	(1)
28	06-95-0209	8-32 x 3/8" Taptite Screw	(3)
29	44-86-0320	Ball Bearing Retainer	(1)
30	02-04-1516	Ball Bearing	(1)

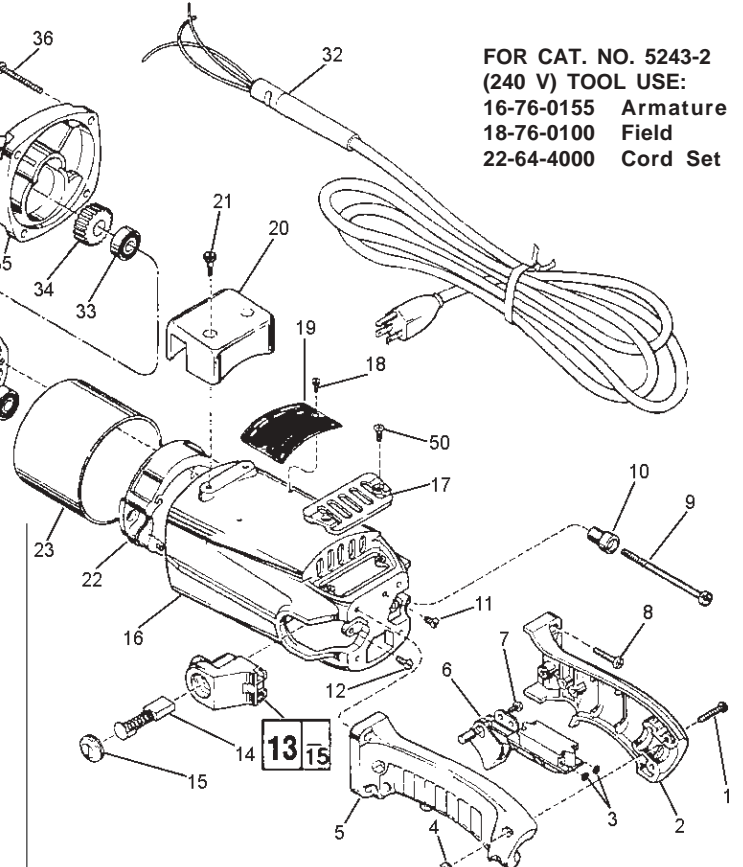

FIG.	PART NO.	DESCRIPTION OF PART	QTY.
42	49-12-0160	6" Wheel Guard	(1)
43	-----	Clamp	(1)
44	06-57-5040	5/16-18 Lock Nut	(2)
45	45-88-0260	Flange Rubber Washer	(2)
46	-----	6" Grinding Wheel (see catalog)	(1)
47	43-34-0330	Outer Wheel Flange	(1)
48	06-55-3250	5/8-11 Hex Nut	(1)
49	22-84-0690	Fan	(1)
50	06-95-3601	8-32 x 3/8" Oval Hd. Taptite Screw	(2)
	49-96-7230	Spanner Wrench	(1)
	49-96-4072	1-1/16" Open End Wrench	(1)

**FIG. 6 NOTES**  
 Assemble Switch to Left Handle Half.

**FIG. 35 LUBRICATION**  
**Important!** Completely clean out old grease from the spindle housing and replace with 1-1/2 Oz. Type "Y" Grease, No. 49-08-5270.



# SERVICE PARTS LIST

**BULLETIN NO.**  
54-22-1031

SPECIFY CATALOG NO. AND SERIAL NO. WHEN ORDERING PARTS		REVISED BULLETIN 54-22-1030	DATE Apr. 2005
<b>6" STRAIGHT GRINDER</b>			
CATALOG NO. 5243	STARTING SERIAL NUMBER	663-7651	
		WIRING INSTRUCTION <b>58-01-0307</b>	

00  
0

**EXAMPLE:**

Component Parts (Small #) Are Included When Ordering The Assembly (Large #).

★ = Part number change from previous service parts list.

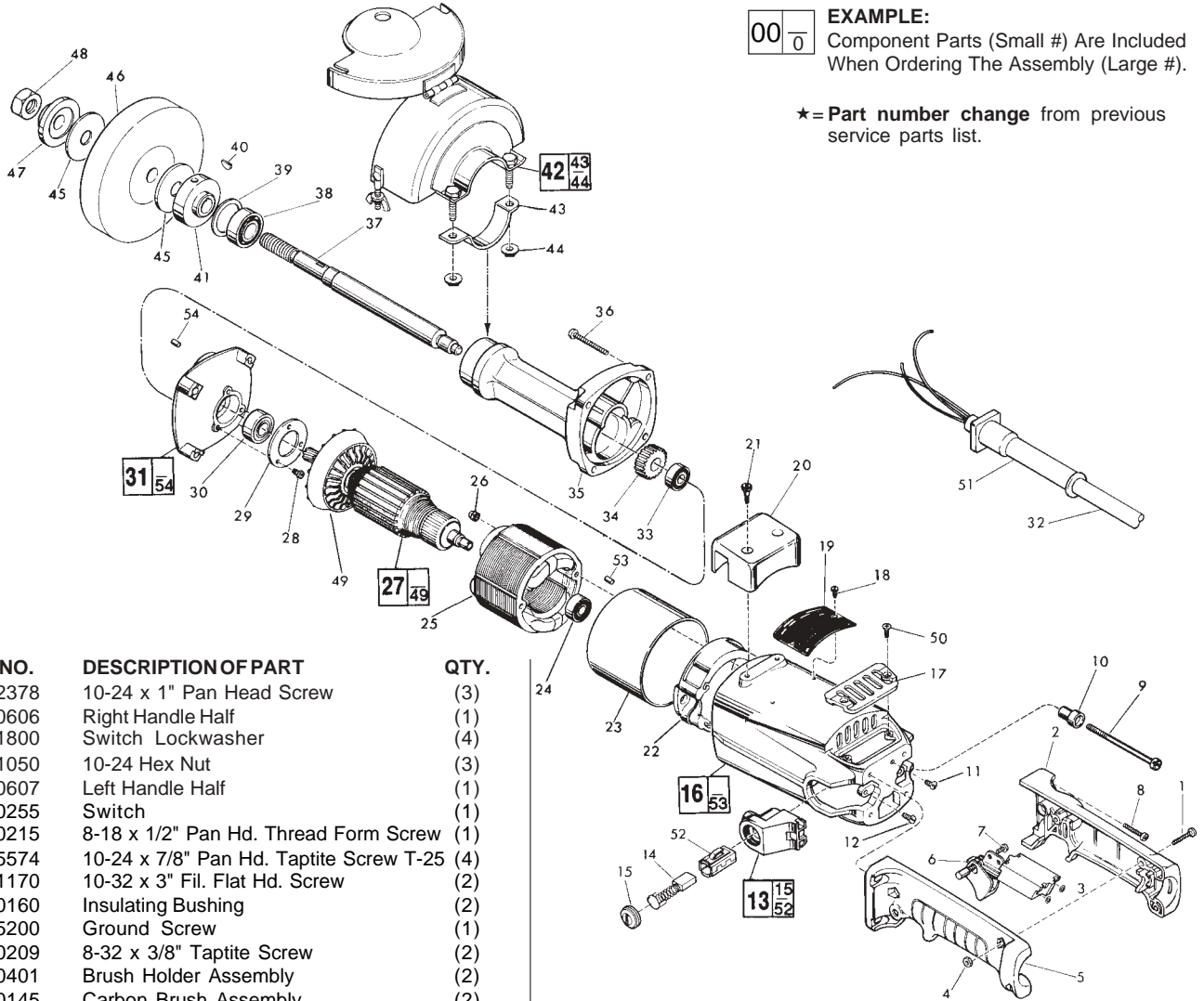

FIG.	PART NO.	DESCRIPTION OF PART	QTY.
★ 1	06-82-2378	10-24 x 1" Pan Head Screw	(3)
★ 2	31-44-0606	Right Handle Half	(1)
3	06-97-1800	Switch Lockwasher	(4)
★ 4	06-55-1050	10-24 Hex Nut	(3)
★ 5	31-44-0607	Left Handle Half	(1)
6	23-66-0255	Switch	(1)
7	06-95-0215	8-18 x 1/2" Pan Hd. Thread Form Screw	(1)
★ 8	06-82-5574	10-24 x 7/8" Pan Hd. Taptite Screw T-25	(4)
9	06-81-1170	10-32 x 3" Fil. Flat Hd. Screw	(2)
10	31-86-0160	Insulating Bushing	(2)
11	06-95-5200	Ground Screw	(1)
12	06-95-0209	8-32 x 3/8" Taptite Screw	(2)
13	22-22-0401	Brush Holder Assembly	(2)
14	22-18-0145	Carbon Brush Assembly	(2)
15	23-44-0170	Brush Retaining Cap	(2)
16	28-50-6351	Motor Housing Assembly	(1)
17	31-15-0310	Cover Plate	(1)
18	06-85-0200	Nameplate Screw	(2)
19	12-99-0241	Nameplate Blank	(1)
20	31-70-0135	Tool Rest	(1)
21	45-04-0530	Shoulder Screw	(2)
22	31-55-0110	Coil Shield	(1)
23	23-16-0950	Insulating Sleeve	(1)
24	02-04-0911	Ball Bearing	(1)
25	18-70-0100	120 Volt Field	(1)
26	06-57-3005	10-32 Locking Hex Nut	(2)
27	16-70-0155	120 Volt Armature	(1)
28	06-95-0209	8-32 x 3/8" Taptite Screw	(3)
29	44-86-0320	Ball Bearing Retainer	(1)
30	02-04-1516	Ball Bearing	(1)
31	28-28-0392	Diaphragm Assembly	(1)
★ 32	22-64-3000	Cord Set	(1)
33	02-04-0910	Ball Bearing	(1)
34	32-75-3160	Spindle Gear	(1)
35	28-50-0400	Spindle Housing	(1)
36	06-95-5650	1/4-20 x 1-1/2" Taptite Screw	(4)
37	38-50-5280	Spindle	(1)
38	02-04-1746	Ball Bearing	(1)
39	34-80-2700	Internal Retaining Ring	(1)
40	06-42-1200	Woodruff Key	(1)
41	43-34-0320	Inner Wheel Flange	(1)

FIG.	PART NO.	DESCRIPTION OF PART	QTY.
42	49-12-0160	6" Wheel Guard	(1)
43	-----	Clamp	(1)
44	06-57-5040	5/16-18 Lock Nut	(2)
45	45-88-0260	Flange Rubber Washer	(2)
46	-----	6" Grinding Wheel (see catalog)	(1)
47	43-34-0330	Outer Wheel Flange	(1)
48	06-55-3250	5/8-11 Hex Nut	(1)
49	22-84-0690	Fan	(1)
50	06-95-3601	8-32 x 3/8" Oval Hd. Taptite Screw	(2)
★ 51	44-76-0170	Cord Protector	(1)
52	22-20-0360	Brush Tube	(2)
53	45-30-0120	Ball Bearing Retaining Slug	(1)
54	45-30-0070	Ball Bearing Retaining Slug	(1)
	49-96-7230	Spanner Wrench	(1)
	49-96-4072	1-1/16" Open End Wrench	(1)

**FIG. 6 NOTES**  
Assemble Switch to Left Handle Half.

**FIG. 35 LUBRICATION**  
**Important!** Completely clean out old grease from the spindle housing and replace with 1-1/2 Oz. Type "Y" Grease, No. 49-08-5270.



# SERVICE PARTS LIST

**BULLETIN NO.**  
54-22-1032

SPECIFY CATALOG NO. AND SERIAL NO. WHEN ORDERING PARTS		REVISED BULLETIN 54-22-1031	DATE May 2005
<b>6" STRAIGHT GRINDER</b>			
CATALOG NO. <b>5243</b>	STARTING SERIAL NUMBER	<b>663B</b>	
		WIRING INSTRUCTION <b>58-01-1307</b>	

00  
0

**EXAMPLE:**

Component Parts (Small #) Are Included When Ordering The Assembly (Large #).

★ = Part number change from previous service parts list.

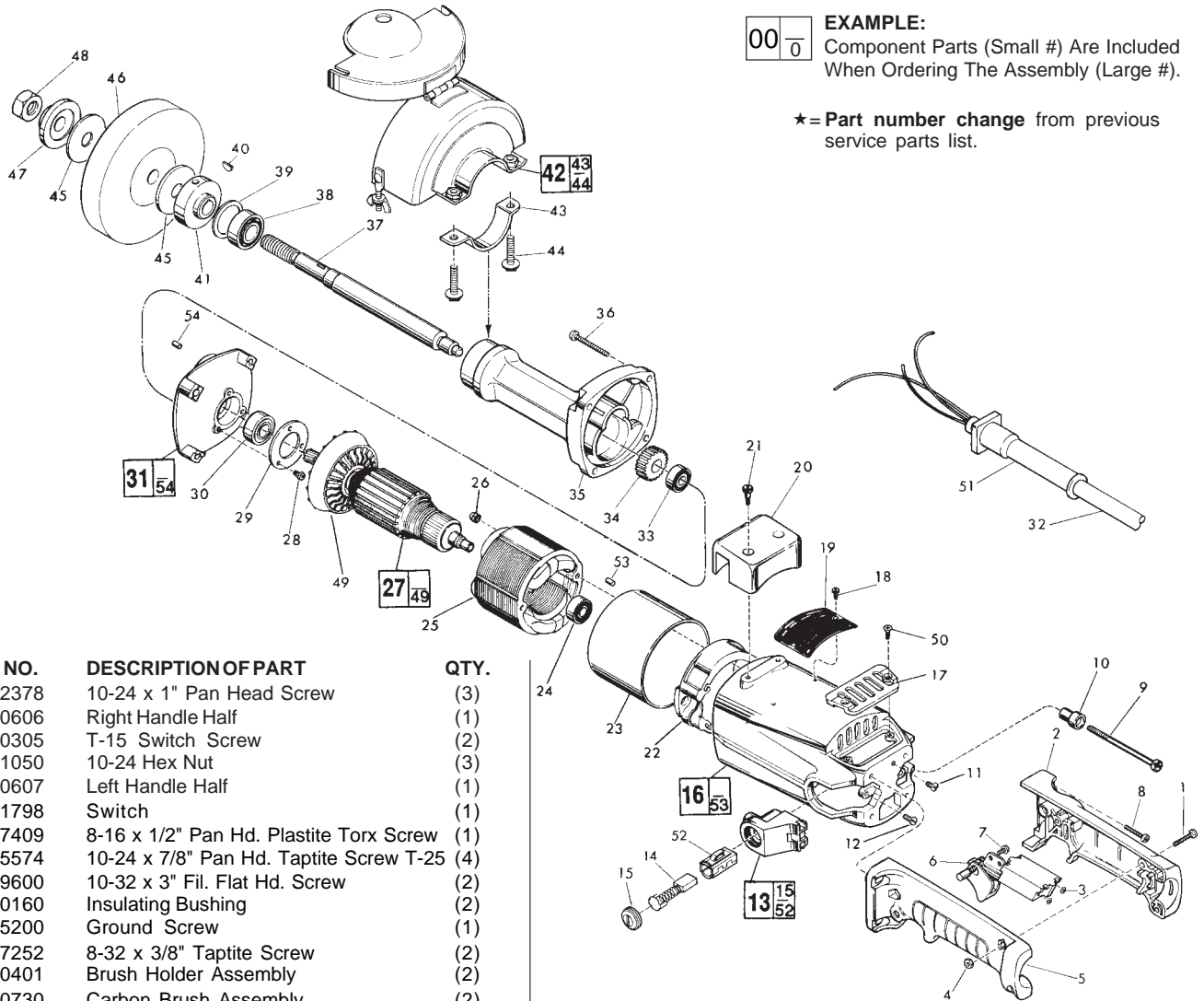

FIG.	PART NO.	DESCRIPTION OF PART	QTY.
	1	10-24 x 1" Pan Head Screw	(3)
	2	Right Handle Half	(1)
★	3	T-15 Switch Screw	(2)
	4	10-24 Hex Nut	(3)
	5	Left Handle Half	(1)
★	6	Switch	(1)
★	7	8-16 x 1/2" Pan Hd. Plastite Torx Screw	(1)
★	8	10-24 x 7/8" Pan Hd. Taptite Screw T-25	(4)
★	9	10-32 x 3" Fil. Flat Hd. Screw	(2)
	10	Insulating Bushing	(2)
	11	Ground Screw	(1)
★	12	8-32 x 3/8" Taptite Screw	(2)
	13	Brush Holder Assembly	(2)
★	14	Carbon Brush Assembly	(2)
	15	Brush Retaining Cap	(2)
	16	Motor Housing Assembly	(1)
	17	Cover Plate	(1)
	18	Nameplate Screw	(2)
	19	Nameplate Blank	(1)
	20	Tool Rest	(1)
★	21	Shoulder Screw	(2)
	22	Coil Shield	(1)
	23	Insulating Sleeve	(1)
★	24	Ball Bearing	(1)
	25	120 Volt Field	(1)
	26	10-32 Locking Hex Nut	(2)
	27	120 Volt Armature	(1)
★	28	8-32 x 3/8" Taptite Screw	(3)
	29	Ball Bearing Retainer	(1)
★	30	Ball Bearing	(1)
	31	Diaphragm Assembly	(1)
	32	Cord Set	(1)
	33	Ball Bearing	(1)
	34	Spindle Gear	(1)
	35	Spindle Housing	(1)
★	36	1/4-20 x 1-1/2" Taptite Screw	(4)
	37	Spindle	(1)
★	38	Ball Bearing	(1)
	39	Internal Retaining Ring	(1)
	40	Woodruff Key	(1)
	41	Inner Wheel Flange	(1)

FIG.	PART NO.	DESCRIPTION OF PART	QTY.
	42	6" Wheel Guard	(1)
★	43	Clamp	(1)
★	44	5/16-18 Grade 8 Bolt	(2)
	45	Flange Rubber Washer	(2)
	46	6" Grinding Wheel (see catalog)	(1)
	47	Outer Wheel Flange	(1)
	48	5/8-11 Hex Nut	(1)
	49	Fan	(1)
★	50	8-32 x 3/8" Oval Hd. Taptite Screw	(2)
	51	Cord Protector	(1)
	52	Brush Tube	(2)
	53	Ball Bearing Retaining Slug	(1)
	54	Ball Bearing Retaining Slug	(1)
		Spanner Wrench	(1)
		1-1/16" Open End Wrench	(1)

**FIG. 6 NOTES**  
Assemble Switch to Left Handle Half.

**FIG. 35 LUBRICATION**  
**Important!** Completely clean out old grease from the spindle housing and replace with 1-1/2 Oz. Type "Y" Grease, No. 49-08-5270.



# SERVICE PARTS LIST

**BULLETIN NO.**  
54-22-1033

SPECIFY CATALOG NO. AND SERIAL NO. WHEN ORDERING PARTS		REVISED BULLETIN	DATE
<b>6" STRAIGHT GRINDER</b>		54-22-1032	Feb. 2009
CATALOG NO. <b>5243</b>	STARTING SERIAL NUMBER <b>663C</b>	WIRING INSTRUCTION <b>58-01-1309</b>	

★ = Part number change from previous service parts list.

FIG.	PART NO.	DESCRIPTION OF PART	QTY.
37	38-50-5280	Spindle	(1)
38	02-04-1745	Ball Bearing	(1)
39	34-80-2700	Internal Retaining Ring	(1)
40	06-42-1200	Woodruff Key	(1)
41	43-34-0320	Inner Wheel Flange	(1)
42	49-12-0160	6" Wheel Guard	(1)
43	42-68-0230	Clamp	(1)
44	06-81-4710	5/16-18 Grade 8 Bolt	(2)
45	45-88-0260	Flange Rubber Washer	(2)
46	-----	6" Grinding Wheel (see catalog)	(1)
47	43-34-0330	Outer Wheel Flange	(1)
48	06-55-3250	5/8-11 Hex Nut	(1)
49	22-84-0690	Fan	(1)

FIG.	PART NO.	DESCRIPTION OF PART	QTY.
1	06-82-2378	10-24 x 1" Pan Head Screw	(3)
★ 2	31-44-0602	Right Handle Half	(1)
★ 3	05-78-0305	T-15 Switch Screw	(4)
4	06-55-1050	10-24 Hex Nut	(3)
★ 5	31-44-0603	Left Handle Half	(1)
★ 6	23-66-1801	Switch	(1)
7	06-82-7409	8-16 x 1/2" Pan Hd. Plastite Torx Screw	(1)
8	06-82-5574	10-24 x 7/8" Pan Hd. Taptite Screw T-25	(4)
9	06-82-9600	10-32 x 3" Fil. Flat Hd. Screw	(2)
10	31-86-0160	Insulating Bushing	(2)
11	06-95-5200	Ground Screw	(1)
12	06-82-7252	8-32 x 3/8" Taptite Screw	(2)
13	22-22-0401	Brush Holder Assembly	(2)
14	22-18-0730	Carbon Brush Assembly	(2)
15	23-44-0170	Brush Retaining Cap	(2)
16	28-50-6351	Motor Housing Assembly	(1)
17	31-15-0310	Cover Plate	(1)
18	06-85-0200	Nameplate Screw	(2)
19	12-99-0241	Nameplate Blank	(1)
20	31-70-0135	Tool Rest	(1)
21	45-04-0720	Shoulder Screw	(2)
22	31-55-0110	Coil Shield	(1)
23	23-16-0950	Insulating Sleeve	(1)
24	02-04-0913	Ball Bearing	(1)
25	18-70-0100	120 Volt Field	(1)
26	06-57-3005	10-32 Locking Hex Nut	(2)
27	16-70-0155	120 Volt Armature	(1)
28	06-82-7252	8-32 x 3/8" Taptite Screw	(3)
29	44-86-0320	Ball Bearing Retainer	(1)
30	02-04-1515	Ball Bearing	(1)
31	28-28-0392	Diaphragm Assembly	(1)
32	22-64-3000	Cord Set	(1)
33	02-04-0910	Ball Bearing	(1)
34	32-75-3160	Spindle Gear	(1)
35	28-50-0400	Spindle Housing	(1)
36	06-82-5514	1/4-20 x 1-1/2" Taptite Screw	(4)

FIG.	PART NO.	DESCRIPTION OF PART	QTY.
50	06-82-3792	8-32 x 3/8" Oval Hd. Taptite Screw	(2)
51	44-76-0170	Cord Protector	(1)
52	22-20-0360	Brush Tube	(2)
53	45-30-0120	Ball Bearing Retaining Slug	(1)
54	45-30-0070	Ball Bearing Retaining Slug	(1)
	49-96-7230	Spanner Wrench	(1)
	49-96-4072	1-1/16" Open End Wrench	(1)

**FIG. NOTES**  
6 Assemble Switch to Left Handle Half.

**FIG. LUBRICATION**  
35 **Important!** Completely clean out old grease from the spindle housing and replace with 1-1/2 Oz. Type "Y" Grease, No. 49-08-5270.

00 0

**EXAMPLE:**  
Component Parts (Small #) Are Included When Ordering The Assembly (Large #).





# SERVICE PARTS LIST

BULLETIN NO.  
55-22-1031

SPECIFY CATALOG NO. AND SERIAL NO. WHEN ORDERING PARTS		REVISED BULLETIN	DATE
6" STRAIGHT GRINDER			May '91
CATALOG NO. 5243-2	STARTING SERIAL NO. 663-6600	WIRING INSTRUCTION 58-01-0307	

EXAMPLE:  
Component Parts ( Small #) Are Included  
When Ordering The Assembly (Large #).



FIG.	PART NO.	DESCRIPTION OF PART	NO. REQ.
35	28-50-0400	Spindle Housing	(1)
36	06-82-5514	1/4-20 x 1-1/2" Pan Hd. Torx Screw	(4)
37	38-50-5280	Spindle	(1)
38	02-04-1746	Ball Bearing	(1)
39	34-80-2700	Internal Retaining Ring	(1)
40	06-42-1200	Woodruff Key	(1)
41	43-34-0320	Inner Wheel Flange	(1)
42	49-12-0160	6" Wheel Guard	(1)
43	42-68-0230	Clamp	(1)
44	06-57-5040	5/16-18 Lock Nut	(2)
45	45-88-0260	Flange Rubber Washer	(2)
46		6" Grinding Wheel (Select From Catalog)	(1)
47	43-34-0330	Outer Wheel Flange	(1)
48	06-55-3250	5/8-11 Hex Nut	(1)
49	22-84-0690	Fan	(1)
50	06-95-3601	8-32 x 3/8" Oval Hd. Taptite Screw	(2)

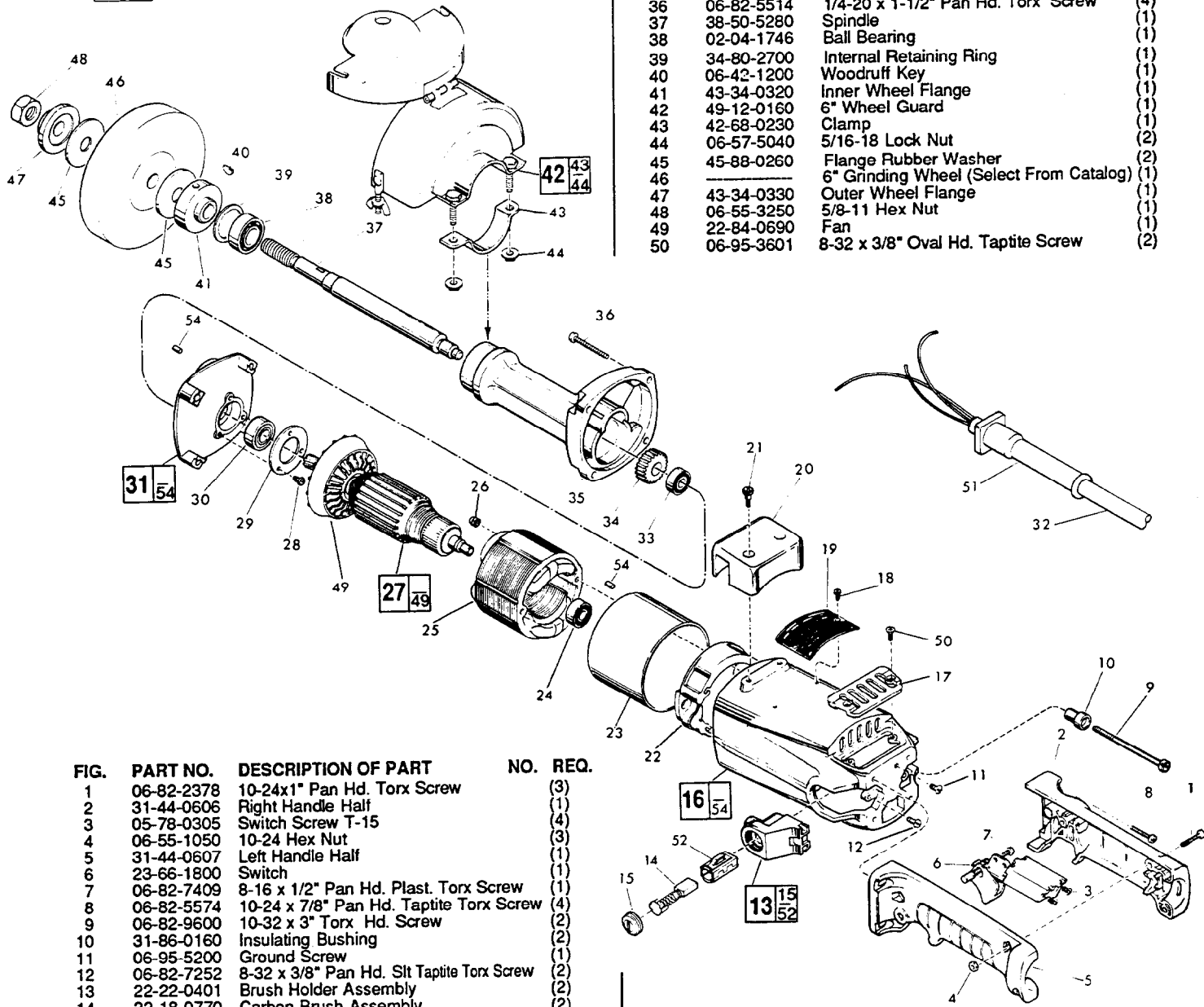

FIG.	PART NO.	DESCRIPTION OF PART	NO. REQ.
1	06-82-2378	10-24x1" Pan Hd. Torx Screw	(3)
2	31-44-0606	Right Handle Half	(1)
3	05-78-0305	Switch Screw T-15	(4)
4	06-55-1050	10-24 Hex Nut	(3)
5	31-44-0607	Left Handle Half	(1)
6	23-66-1800	Switch	(1)
7	06-82-7409	8-16 x 1/2" Pan Hd. Plast. Torx Screw	(1)
8	06-82-5574	10-24 x 7/8" Pan Hd. Taptite Torx Screw	(4)
9	06-82-9600	10-32 x 3" Torx Hd. Screw	(2)
10	31-86-0160	Insulating Bushing	(2)
11	06-95-5200	Ground Screw	(1)
12	06-82-7252	8-32 x 3/8" Pan Hd. Slit Taptite Torx Screw	(2)
13	22-22-0401	Brush Holder Assembly	(2)
14	22-18-0770	Carbon Brush Assembly	(2)
15	23-44-0170	Brush Retaining Cap	(1)
16	28-50-6351	Motor Housing Assembly	(1)
17	31-15-0310	Cover Plate	(1)
18	06-85-0200	Nameplate Screw	(2)
19	12-99-0241	Nameplate Blank	(1)
20	31-70-0135	Tool Rest	(1)
21	45-04-0720	Shoulder Screw	(2)
22	31-55-0110	Coil Shield	(1)
23	23-16-0950	Insulating Sleeve	(1)
24	02-04-0911	Ball Bearing	(1)
25	18-75-0100	240 Volt Field	(1)
26	06-57-3005	10-32 Locking Hex Nut	(2)
27	16-76-0155	240 Volt Armature	(1)
28	06-82-7252	8-32 x 3/8" Pan Hd. Slit Taptite Torx Screw	(3)
29	44-85-0320	Ball Bearing Retainer	(1)
30	02-04-1515	Ball Bearing	(1)
31	28-28-0302	Diaphragm Assembly	(1)
32	22-64-4510	Cord Set	(1)
33	02-04-0910	Ball Bearing	(1)
34	32-75-3160	Spindle Gear	(1)

FIG.	PART NO.	DESCRIPTION OF PART	NO. REQ.
51	44-76-0170	Cord Protector	(1)
52	22-20-0360	Brush Tube	(2)
54	45-30-0070	Ball Bearing Retaining Slug	(2)
	49-96-7230	Spanner Wrench	(1)
	49-96-4072	1-1/16" Open End Wrench	(1)

FIG. 6 NOTES  
Assemble Switch To Left Handle Half.  
FIG. LUBRICATION  
35 1-1/2 Oz. Type "G" Grease, No. 49-08-4140.



# SERVICE PARTS LIST

**BULLETIN NO.**  
**55-22-1032**

SPECIFY CATALOG NO. AND SERIAL NO. WHEN ORDERING PARTS		REVISED BULLETIN 55-22-1031	DATE Jan. '99
<b>6" STRAIGHT GRINDER</b>			
CATALOG NO. <b>5243-2</b>	STARTING SERIAL NUMBER	<b>663B</b>	
		WIRING INSTRUCTION <b>58-01-1307</b>	

00/0

**EXAMPLE:**  
Component Parts (Small #) Are Included  
When Ordering The Assembly (Large #).

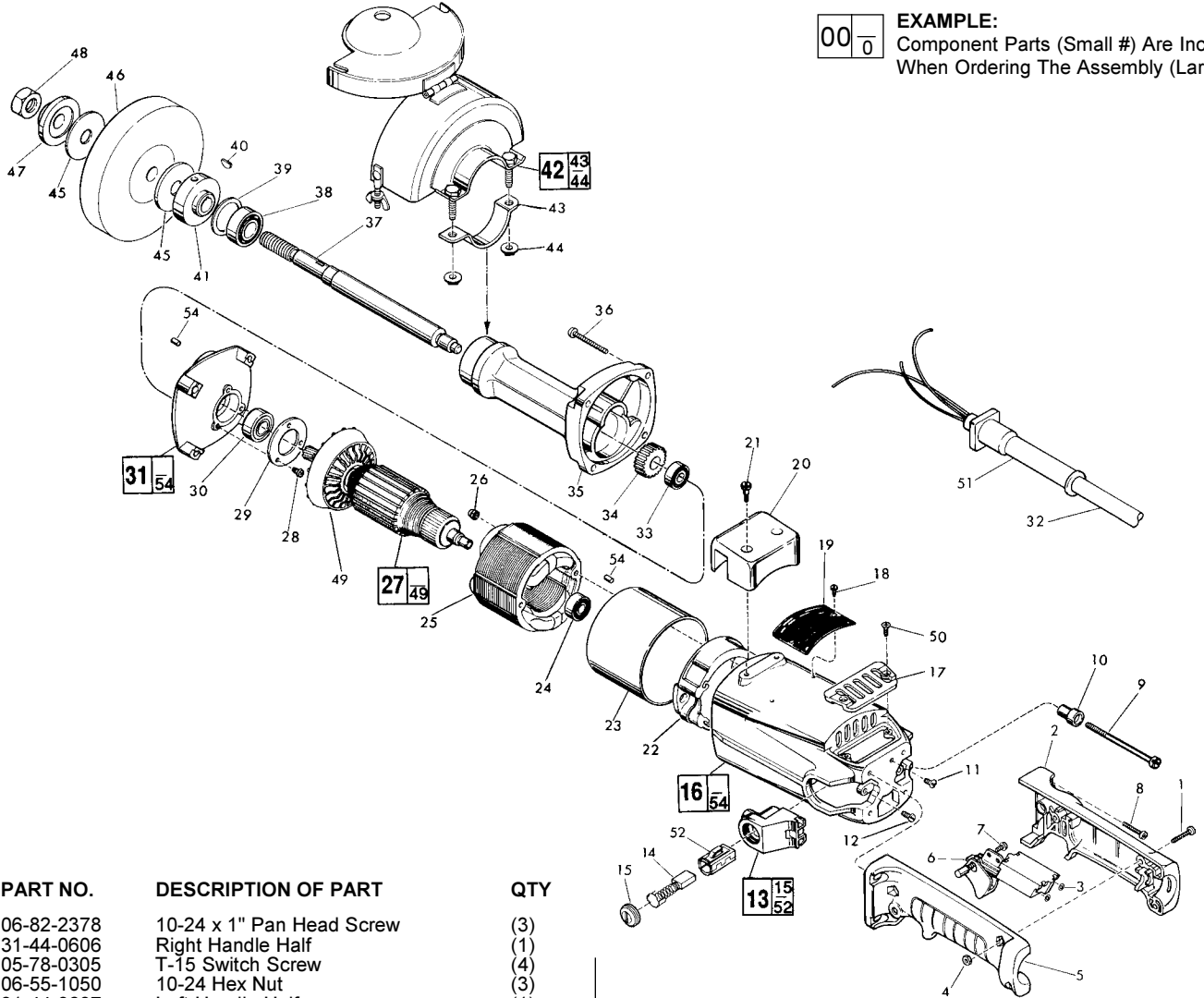

FIG.	PART NO.	DESCRIPTION OF PART	QTY
1	06-82-2378	10-24 x 1" Pan Head Screw	(3)
2	31-44-0606	Right Handle Half	(1)
3	05-78-0305	T-15 Switch Screw	(4)
4	06-55-1050	10-24 Hex Nut	(3)
5	31-44-0607	Left Handle Half	(1)
★ 6	23-66-1798	Switch	(1)
7	06-82-7409	8-16 x 1/2" Pan Hd. Plast. Torx Screw	(1)
8	06-82-5574	10-24 x 7/8" Pan Hd. Tapt. Torx Screw	(4)
9	06-82-9600	10-32 x 3" Torx Hd. Screw	(2)
10	31-86-0160	Insulating Bushing	(2)
11	06-95-5200	Ground Screw	(1)
12	06-82-7252	8-32 x 3/8" Pan Hd. Taptite Torx Screw	(2)
13	22-22-0401	Brush Holder Assembly	(2)
14	22-18-0770	Carbon Brush Assembly	(2)
15	23-44-0170	Brush Retaining Cap	(2)
16	28-50-6351	Motor Housing Assembly	(1)
17	31-15-0310	Cover Plate	(1)
18	06-85-0200	Nameplate Screw	(2)
19	12-99-0241	Nameplate Blank	(1)
20	31-70-0135	Tool Rest	(1)
21	45-04-0720	Shoulder Screw	(2)
22	31-55-0110	Coil Shield	(1)
23	23-16-0950	Insulating Sleeve	(1)
24	02-04-0911	Ball Bearing	(1)
25	18-76-0100	240 Volt Field	(1)
26	06-57-3005	10-32 Locking Hex Nut	(2)
27	16-76-0155	240 Volt Armature	(1)
28	06-82-7252	8-32 x 3/8" Pan Hd. Taptite Torx Screw	(3)
29	44-86-0320	Ball Bearing Retainer	(1)
30	02-04-1515	Ball Bearing	(1)
31	28-28-0392	Diaphragm Assembly	(1)
32	22-64-4510	Cord Set	(1)
33	02-04-0910	Ball Bearing	(1)
34	32-75-3160	Spindle Gear	(1)
35	28-50-0400	Spindle Housing	(1)
36	06-82-5514	1/4-20 x 1-1/2" Pan Hd. Torx Screw	(4)

FIG.	PART NO.	DESCRIPTION OF PART	QTY
37	38-50-5280	Spindle	(1)
38	02-04-1746	Ball Bearing	(1)
39	34-80-2700	Internal Retaining Ring	(1)
40	06-42-1200	Woodruff Key	(1)
41	43-34-0320	Inner Wheel Flange	(1)
42	49-12-0160	6" Wheel Guard	(1)
★ 43	-----	Clamp	(1)
44	06-57-5040	5/16-18 Lock Nut	(2)
45	45-88-0260	Flange Rubber Washer	(2)
46	-----	6" Grinding Wheel (see catalog)	(1)
47	43-34-0330	Outer Wheel Flange	(1)
48	06-55-3250	5/8-11 Hex Nut	(1)
49	22-84-0690	Fan	(1)
★ 50	06-82-3792	8-32 x 3/8" Oval Hd. Taptite Screw	(2)
51	44-76-0170	Cord Protector	(1)
52	22-20-0360	Brush Tube	(2)
54	45-30-0070	Ball Bearing Retaining Slug	(1)
	49-96-7230	Spanner Wrench	(1)
	49-96-4072	1-1/16" Open End Wrench	(1)

**FIG. NOTES**

6 Assemble Switch to Left Handle Half.

**FIG. LUBRICATION**

35 1-1/2 oz. Type "G" Grease, Cat. No. 49-08-4140