



SERVICE PARTS LIST

BULLETIN NO.
54-05-6110

SPECIFY CATALOG NO. AND SERIAL NO. WHEN ORDERING PARTS		REVISED BULLETIN
CUTTING DUST SHROUD		
CATALOG NO. 49-40-6110	STARTING SERIAL NO.	

EXAMPLE:

00	0
----	---

 Component Parts (Small #)
 Are Included When Ordering
 The Assembly (Large #).

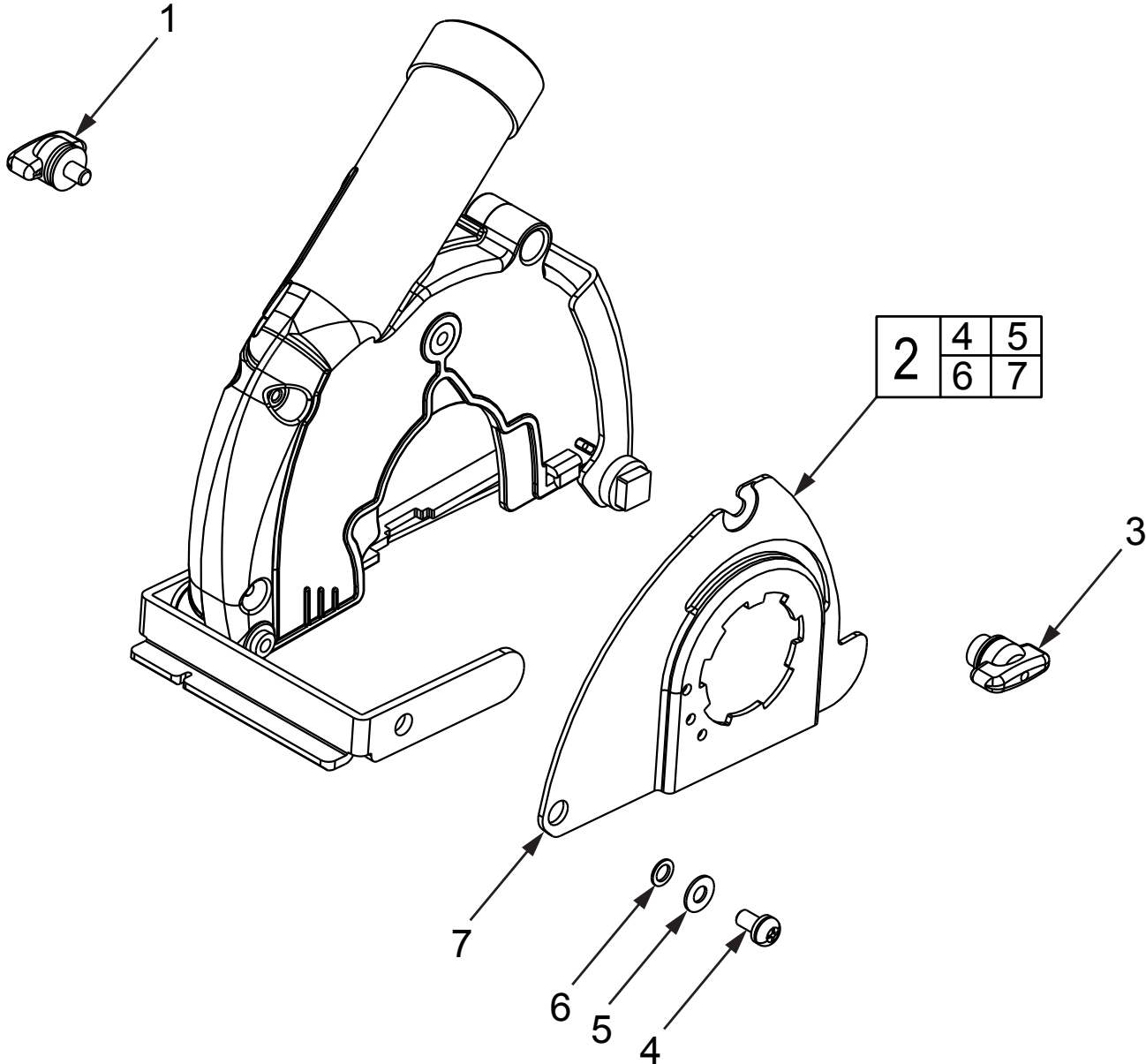

FIG.	PART NO.	DESCRIPTION OF PART	NO. REQ.
1	31-12-0061	Depth Gauge Twist Assembly	(1)
2	31-76-0020	Shroud Collar Kit	(1)
3	31-12-0060	Shroud Collar Twist Cap Assembly	(1)
4	-----	Screw	(1)
5	-----	Washer	(1)
6	-----	Washer	(1)
7	-----	Shroud Collar	(1)
8	10-20-1286	Nameplate (Not Shown)	(1)

FIG. NOTES
 8 A clean, dry surface is essential for proper performance for any adhesive system. The area intended for application of any adhesive label or nameplate must be prepared by cleaning with isopropyl alcohol. The solvent is to be applied with a clean, lint free applicator and the surface allowed to dry before applying the label or nameplate.